

# TM 11-242

WAR DEPARTMENT TECHNICAL MANUAL

STK. NO. 6D13059

O.K.  
42

## RADIO SET SCR - 300 - A

**RESTRICTED. DISSEMINATION OF RESTRICTED MATTER.**—The information contained in restricted documents and the essential characteristics of restricted material may be given to any person known to be in the service of the United States and to persons of undoubted loyalty and discretion who are cooperating in Government work, but will not be communicated to the public or to the press except by authorized military public relations agencies. (See also par. 23b, AR 380-5, 15 Mar 1944.)

WAR DEPARTMENT TECHNICAL MANUAL  
TM 11-242

*This manual supersedes TM 11-242, 15 June 1943, and TB 11-242-1, 14 July 1944.*

---

**RADIO SET**  
**SCR - 300 - A**



WAR DEPARTMENT • FEBRUARY 1945

---

**RESTRICTED. DISSEMINATION OF RESTRICTED MATTER.**

The information contained in restricted documents and the essential characteristics of restricted material may be given to any person known to be in the service of the United States and to persons of undoubted loyalty and discretion who are cooperating in Government work, but will not be communicated to the public or to the press except by authorized military public relations agencies. (See also par. 23*l*, AR 380-5, 15 Mar 44.)

---

WAR DEPARTMENT

WASHINGTON 25, D. C., 26 February 1945

TM 11-242, Radio Set SCR-300-A, is published for the information and guidance of all concerned.

[AG 300.7 (6 Oct 44)]

BY ORDER OF THE SECRETARY OF WAR:

G. C. MARSHALL  
*Chief of Staff*

OFFICIAL:

J. A. ULIO  
*Major General*  
*The Adjutant General*

DISTRIBUTION:

AAF (5); AGF (5); ASF (2); T of Opn (5); Dept (5); Def Comd (2); Base Comd (5); AAF Comd (2); Arm & Sv Bd (2); S Div ASF (1); Tech Sv (2); SvC (5); Area ASvC (2); WDGS Lib (5); PC&S (2); PE (2); Dep 11 (2); Gen Oversea SOS Dep (Sig Sec) (2); GH (2); M Conc C (2); Air Base Hosp (2); Gen Sv Sch (5); Sp Sv Sch (10); USMA (10); ROTC (5); Lab 11 (2); Sig AS (2); Rep Shop 11 (2); A (5); D (2); AF (2); Five (5) copies to each of the following T/O & E's: 3-27; 4-157S; 5-226; 5-227; 5-228; 5-517S; 6-197; 6-212S; 6-277T; 7-12; 7-14; 7-16; 7-19; 7-32; 7-36; 7-52; 7-56; 7-86; 7-96; 8-177T; 11-7; 11-107; 11-127; 11-237; 11-517S; 11-557; 11-587; 11-592; 11-597; 19-56; 44-476T; 44-477T; 55-47; 71-10-1S.

For explanation of symbols, see FM 21-6.

# CONTENTS

	<i>Paragraphs</i>	<i>Page</i>
<b>CHAPTER 1. GENERAL</b>		
SECTION I. Description .....	1-14	1
II. Installation .....	15-20	12
III. Initial adjustments .....	21-24	22
<b>CHAPTER 2. OPERATING INSTRUCTIONS</b>		
SECTION I. Controls .....	25	26
II. Operation .....	26-29	28
III. Equipment performance check list .....	30	34
<b>CHAPTER 3. PREVENTIVE MAINTENANCE</b>		
SECTION I. Preventive maintenance techniques .....	31-32	38
II. Itemized preventive maintenance .....	33-44	40
III. Lubrication .....	45	49
IV. Moistureproofing and fungiproofing .....	46-48	49
<b>CHAPTER 4. AUXILIARY EQUIPMENT</b>		
SECTION I. Antenna Equipment RC-291-( ) .....	49-56	53
II. Microphone T-45 and Cord CD-318 .....	57-63	58
III. Packboard transport .....	64-68	62
<b>CHAPTER 5. REPAIR INSTRUCTIONS</b>		
SECTION I. Theory of equipment .....	69-91	66
II. Trouble shooting .....	92-93	95
III. Trouble-shooting procedures .....	94-100	96
IV. Repair .....	101-115	115
V. Alignment procedures .....	116-119	142
VI. Minimum test requirements for repaired Radio Receiver and Transmitter BC-1000-A	120-130	152
<b>APPENDIX</b> .....		160

# RESTRICTED

## DESTRUCTION NOTICE

---

**WHY** —To prevent the enemy from using or salvaging this equipment for his benefit.

**WHEN**—When ordered by your commander.

- HOW** —1. Smash—Use sledges, axes, handaxes, pickaxes, hammers, crowbars, heavy tools.
2. Cut—Use axes, handaxes, machetes.
3. Burn—Use gasoline, kerosene, oil, flame throwers, incendiary grenades.
4. Explosives—Use firearms, grenades, TNT.
5. Disposal—Bury in slit trenches, fox holes, other holes. Throw in streams. Scatter.

### USE ANYTHING IMMEDIATELY AVAILABLE FOR DESTRUCTION OF THIS EQUIPMENT

- WHAT**—1. Smash—Headset, handset, all tubes, insulation, capacitors, resistors, transformers, knobs, gearings, batteries, panels, castings, relays, switches, etc.
2. Cut—All wiring in electrical circuits, battery connecting cables, etc.
3. Burn—All instruction books, circuit diagrams, insulation, codes, etc.
4. Bend—All antenna sections, switch lever contacts, chassis, etc.
5. Bury or scatter—Where possible dispose of debris in streams or bury.

### DESTROY EVERYTHING

## SAFETY NOTICE

---

There is no danger of an electrical shock at any point in this set when it is in operation. When the chassis is out of the case and connected to the battery, be careful, as high voltages of 90 and 150 volts are present at many points on the bottom of the chassis.



# RESTRICTED

This manual supersedes TM 11-242, 15 June 1943 and TB11-242-1, 14 July 1944.

## Chapter I

# GENERAL

## Section I. DESCRIPTION

### 1. Purpose

Radio Set SCR-300-A consists of an 18-tube, low-power, dry-battery-operated, portable radio receiver and transmitter and accessories. It is designed for frequency-modulated, two-way communication over short distances. It is primarily intended as a *walkie-talkie* for foot combat troops. However, it is also readily adaptable for fixed-station use. The complete radio installation weighs only 38.23 pounds with Battery BA-70, or 32.23 pounds with Battery BA-80.

### 2. Application

a. GENERAL. The receiver of Radio Receiver and Transmitter BC-1000-A, main component of Radio Set SCR-300-A, uses a double super-heterodyne circuit. The transmitter is frequency modulated. The transmitter and receiver frequencies are the same for each channel and are varied by a single, ganged TUNING control. A simple block diagram of Radio Set SCR-300-A is shown in figure 1. The functions of certain supplementary circuits are described below.

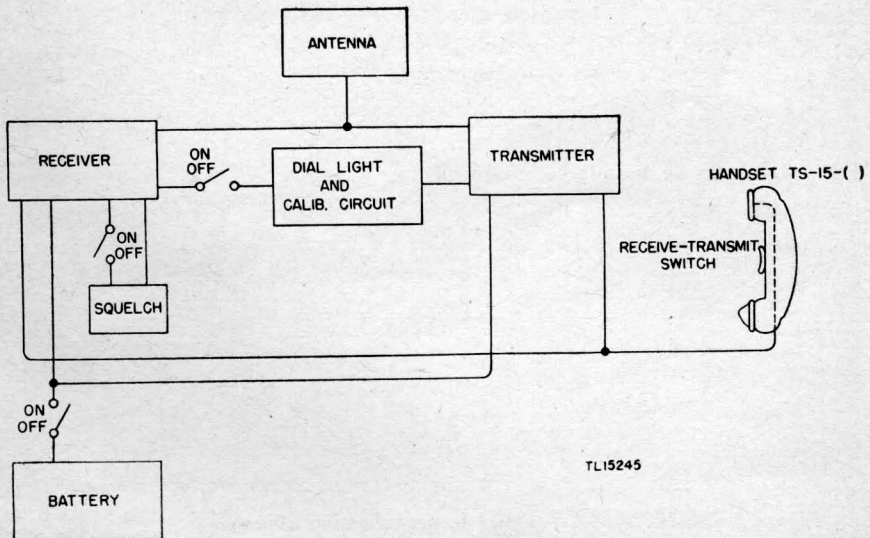

Figure 1. Radio Set SCR-300-A—simplified block diagram.



b. SQUELCH CIRCUIT. As a result of the high-grain circuits of the receiver, atmospheric disturbances will normally produce a continuous roar in its output. To eliminate this roar during stand-by periods, a squelch circuit has been incorporated in the set. The squelch circuit automatically squelches the roar during no-signal periods and opens to allow full amplification when signals are received. The SQUELCH control should be carefully adjusted and checked from time to time, because if carelessly and improperly used it will reduce the range and sensitivity of the receiver.

c. CALIBRATION. Provision is made to calibrate Radio Receiver and Transmitter BC-1000-A without the aid of external equipment. This is done by checking the calibration mark on the CHANNEL dial against a beat note produced by the transmitter mixer and crystal oscillator. If the CHANNEL dial setting is wrong, it may be corrected by adjusting the placement of the hairline on the CHANNEL dial window with the INDICATOR ADJUSTMENT. By pressing the PRESS FOR DIAL LIGHT & CALIB. button, the crystal oscillator of the transmitter is made to function while the receiver is operating. This operation creates

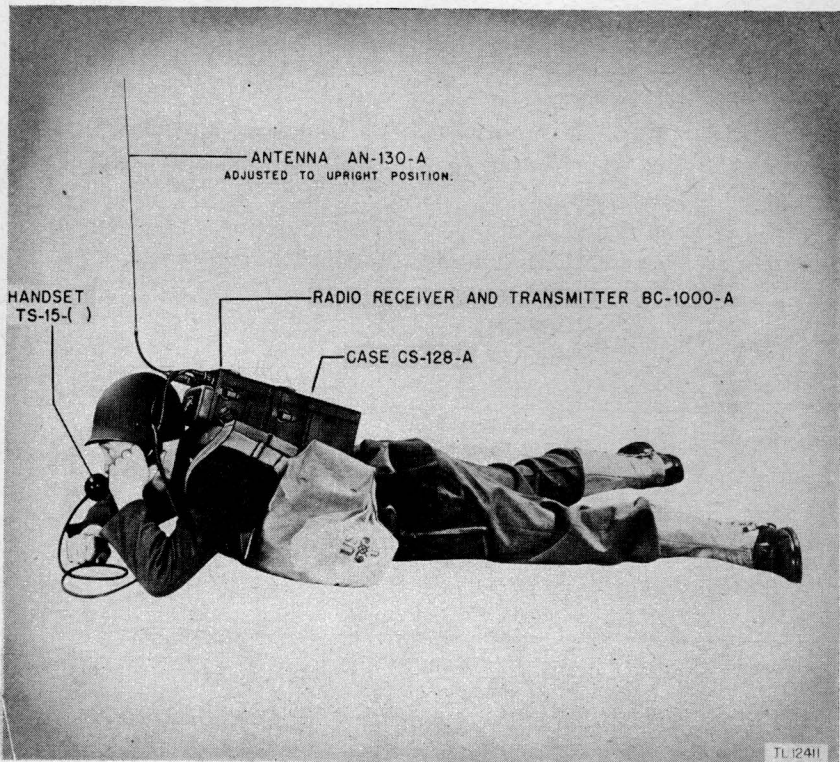

Figure 2. Radio Set SCR-300-A in use, showing adjustment of Antenna AN-130-A.

the beat note at the calibration marks, and simultaneously illuminates the dial lamp, thus facilitating tuning and calibration adjustments.

*d.* RECEIVE-TRANSMIT SWITCH. Change-over from reception to transmission is accomplished by operating the switch on the handle of the handset. The switch effects the change-over by turning of the filaments of the radio frequency (r-f) amplifier tube VI and the transmitter mixer tube V2.

*e.* TYPE OF ANTENNA. Radio Set SCR-300-A is designed for transmission and reception with a vertically polarized antenna. Therefore, great care must be taken to maintain the antenna in a vertical position at all times, regardless of the position of the set. (See fig. 2.)

*f.* APPLICATION OF POWER. Two series switches control the application of power to the set. Since these switches are in series, it is necessary that both be closed to make the set function. Plugging the handset or headset into the jack marked PHONE No. 1 closes one switch, and turning the VOLUME control in a clockwise direction closes the other.

### 3. Technical Data

The table below lists the technical data and general characteristics of Radio Set SCR-300-A.

*Table 1. Technical characteristics*

Frequency range:

Transmitter .....	40.0 to 48.0 mc
Receiver .....	40.0 to 48.0 mc
Types of signals emitted.....	f-m voice
Types of signals which can be received.....	f-m voice
Type of modulation.....	frequency modulation
Antenna type .....	whip
Number of tubes.....	18
Distance range .....	3 miles, approximately
Dial graduation.....	41 numbered channels

<i>Dial No.</i>	<i>Frequency (mc)</i>	<i>Dial No.</i>	<i>Frequency (mc)</i>
0	40.0	10	42.0
1	40.2	30	46.0
3	40.6	40	48.0

Frequency separation between dial divisions.....	0.2 mc (200 kc)
Type of transmitter.....	f-m reactance modulated
Type of receiver.....	f-m double superheterodyne
Sidetone in set.....	yes
Method of calibration.....	10th and 11th harmonics of 4.3-mc crystal provide for calibration at 43.0 and 47.3 mc, respectively.

Power output:

Transmitter .....	0.3 watts (rf)
Receiver .....	2 milliwatts (af)
Power supply .....	dry Battery BA-70 or BA-80

## Power input:

## Transmitter:

Filaments .....	4.5 volts (normal), 3.6 volts (min), 0.5 amps (max)
Plate .....	90 volts (normal), 66 volts (min), 25 ma (max) 150 volts (normal), 110 volts (min), 50 ma (max)

## Receiver:

Filaments .....	4.5 volts (normal), 3.6 volts (min), 0.3 amp (max)
Plate .....	90 volts (normal), 66 volts (min), 25 ma (max)

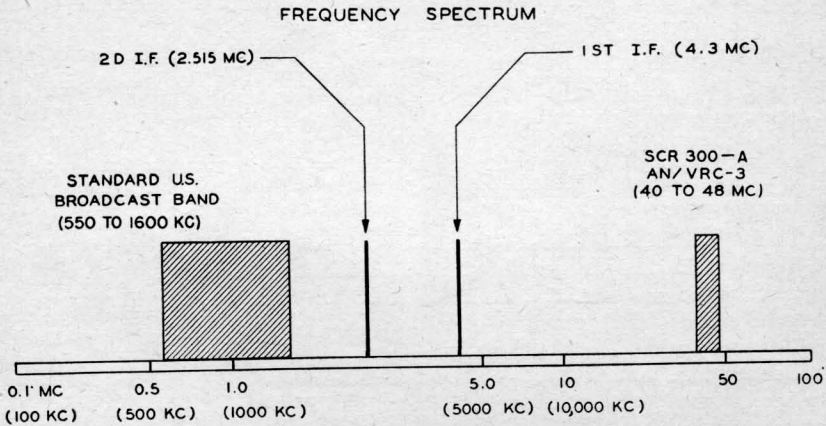

Figure 3. Radio Set SCR-300-A—frequency spectrum chart.

#### 4. Communication with Other Radio Sets

Radio Set SCR-300-A has a frequency coverage of 40 to 48 megacycles (mc) which is exactly the same as that of Radio Set AN/VRC-3. Therefore these two sets can be used for intercommunication. (See fig. 3.)

#### 5. Component Parts

The equipment listed in the following table and illustrated in figure 4, is necessary for the operation of Radio Set SCR-300-A. Check and correct this list upon receiving equipment. This table is to be used as a guide and not as a basis for issue.

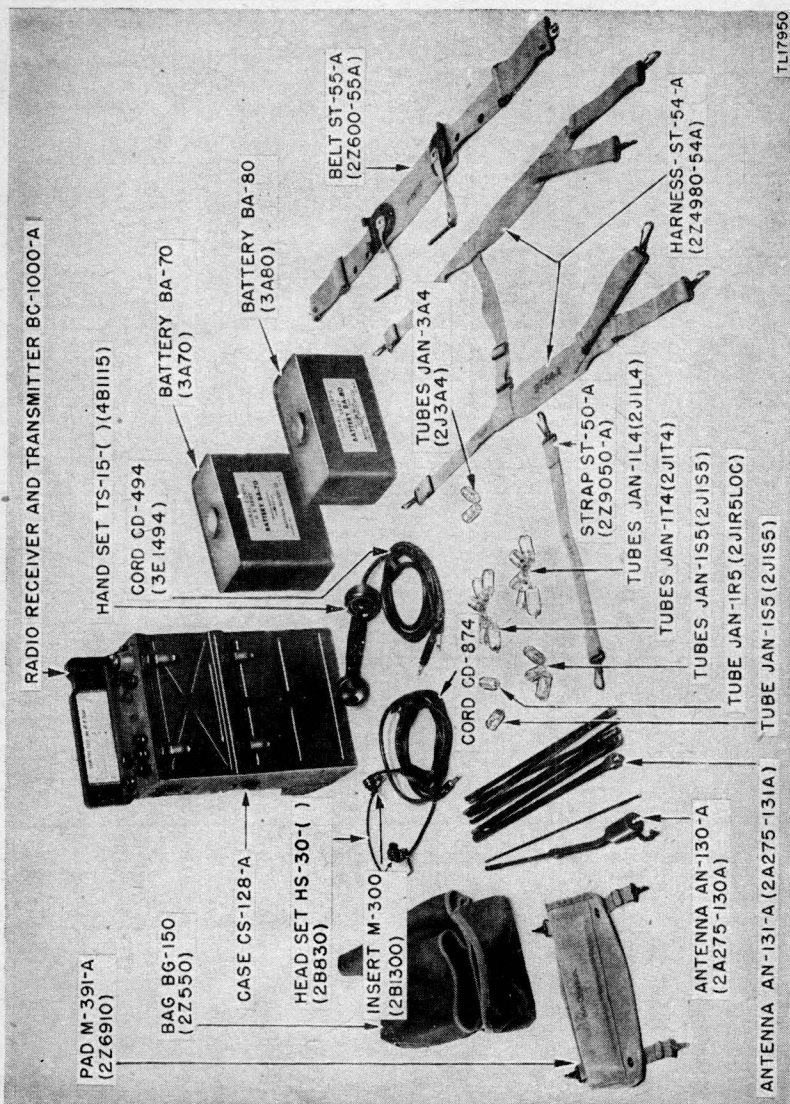

Figure 4. Radio Set SCR-300-A—component parts  
(Numbers in parentheses are Signal Corps stock numbers).

Table 11. Components with weights and dimensions

Quantity	Name of component	Dimensions (in.)					Unit weight (lb.)
		Height	Width	Depth	Length	Diameter	
1	Antenna AN-130-A (2-section).				33 (assembled), 17 (collapsed).	1 (max)	0.39
1	Antenna AN-131-A (8-section).				128 (assembled), 17 (collapsed).	21/32 (max)	0.93
1	Bag BG-150-A for— 1 Handset TS-15-( ) 1 Handset HS-30-( ) 1 Antenna AN-130-A. 1 Antenna AN-131-A.		7¼	27/8	17½		0.66 (empty)
1	Battery BA-70*	7-23/32					15.00
1	Battery BA-80*	5¼		4½			9.00
1	Belt ST-55-A		10-5/16	4½			0.75
1	Handset TS-15-( ) with Cord CD-494.		3		43 (extended).		1.80
1	Harness ST-54-A		14¼ (extended).		38¼ (extended).		0.72
1	Headset HS-30-( ) with Cord CD-874.						0.57
1	Pad M-391-A	6½	11				0.40
1	Radio Receiver and Transmitter BC-1000-A including the following: 1 Crystal Holder FT-243 with 4,300-kc crystal. 1 Crystal Holder FT-243 with 6,815-kc crystal. 1 Lamp LM-52 (dial light).	5½	11-5/16	7½			13.00

Quantity	Name of component	Dimensions (in.)				Unit weight (lb.)
		Height	Width	Depth	Length	
1	1 Set of tubes consisting of— 1 JAN-1R5/VT-171 3 JAN-1S5/VT-172 6 JAN-1T4/VT-173 1 JAN-1A3 5 JAN-1L4 2 JAN-3A4 1 Chassis case ..... Case CS-128-A for Battery BA-70, clips to chassis case. Strap ST-50-A for carrying Radio Set SCR-300-A.	9 $\frac{3}{8}$	10-15/16	7 $\frac{1}{4}$		3.66
1	TM 11-242 for Radio Set SCR-300-A.	8 $\frac{1}{2}$	1		17 $\frac{1}{2}$	0.10
2			5 $\frac{1}{2}$			0.25

( ) denotes the applicable issue letter.  
 \* Battery BA-80 is interchangeable with Battery BA-70.  
 These notes apply throughout the text

## 6. Shipping Weights and Dimensions of Packed Sets

a. The single Radio Set SCR-300-A is packed in a cardboard carton  $20\frac{7}{8}$  inches long,  $15\frac{1}{8}$  inches wide, and  $10\frac{1}{4}$  inches deep. The total weight is  $35\frac{1}{2}$  pounds. For dimensions of the unpacked set, see figure 5 and consult table II.

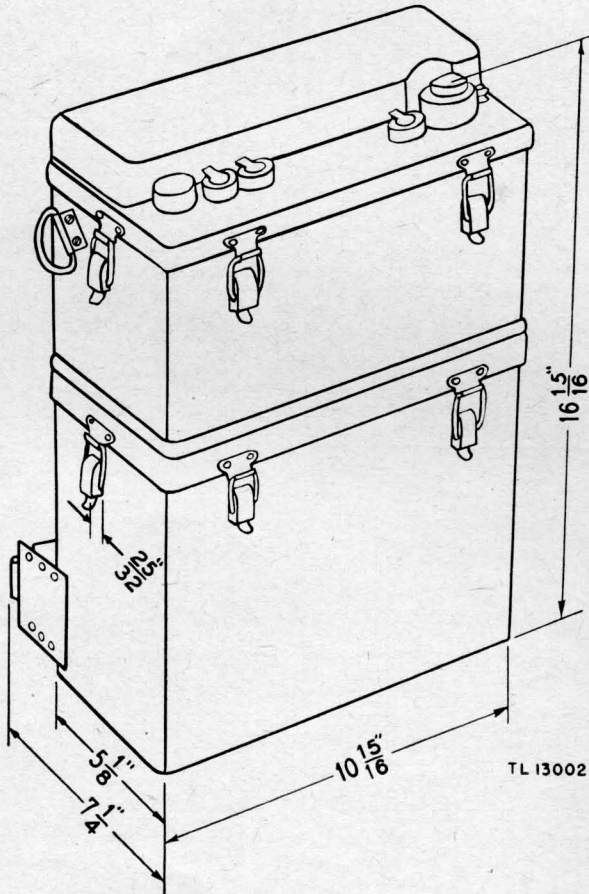

Figure 5. Radio Receiver and Transmitter BC-1000-A—outline dimensional drawing.

b. Four Radio Sets SCR-300-A are packed in a wooden case 35 inches long,  $24\frac{1}{4}$  inches wide, and  $24\frac{1}{4}$  inches high. The total weight is 215 pounds.

## 7. Radio Receiver and Transmitter BC-1000-A

The Radio Receiver and Transmitter BC-1000-A consists of the radio chassis and front panel of the set mounted in a metal case. All the con-

trols, jacks, and terminals are mounted on the front panel; a hinged metal panel cover fits over some of the controls and jacks. (See fig. 6.)

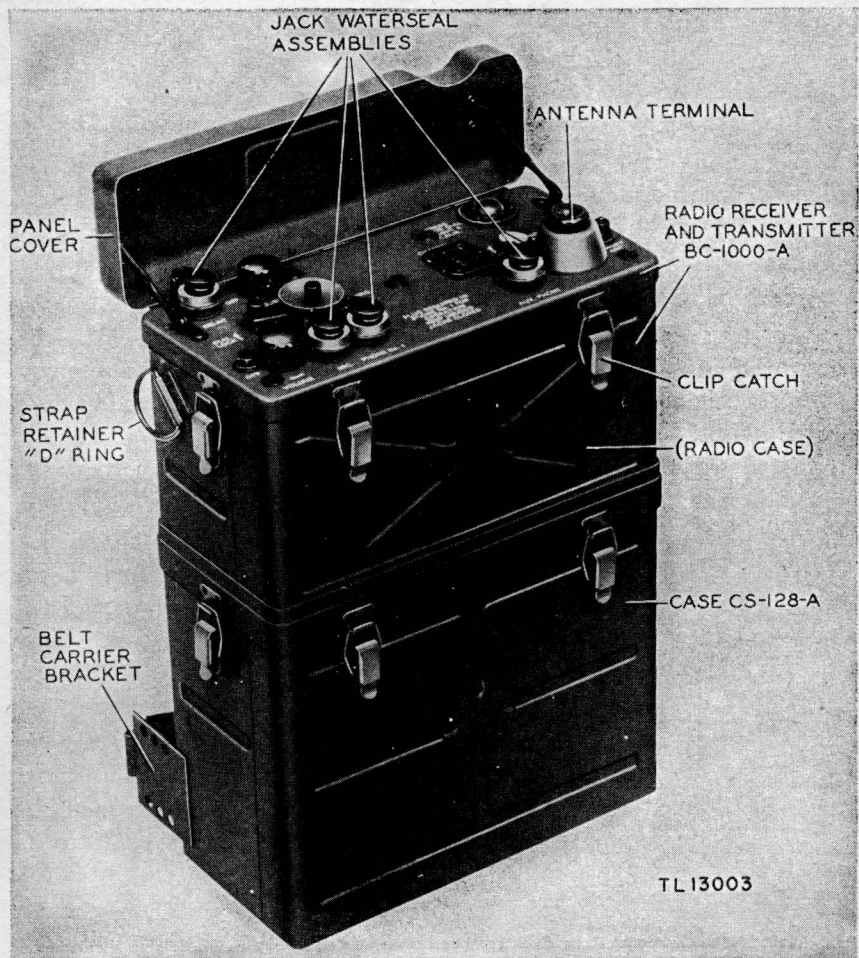

Figure 6. Radio Receiver and Transmitter BC-1000-A, with Case CS-128-A attached.

**a. HOUSING.** The waterproof housing is divided into two sections. The top section of the housing (part of Radio Receiver and Transmitter BC-1000-A) houses the radio chassis. A socket in the bottom of the chassis case provides for connection to Battery BA-70 or BA-80. The bottom section of the housing or Case CS-128-A (fig. 6) covers and waterproofs but does not carry the weight of Battery BA-70 or BA-80.

**b. CONTROLS.** For a description of the controls of Radio Receiver and Transmitter BC-1000-A, see paragraph 25.



c. **WATERSEALS.** Synthetic rubber gaskets act as waterseals to provide protection against moisture. Special waterseal assemblies prevent moisture from entering through the jacks on the front panel. (See fig. 6.)

### 8. Handset TS-15-( )

Handset TS-15-( ) with Cord CD-494 terminates in Plug PL-55 (receiver unit) and Plug PL-68 (microphone). A receive-transmit switch is incorporated in the handle. The receiver unit of Handset TS-15-( ) has an impedance of 250 ohms.

### 9. Headset HS-30-( ) and Cord CD-874

a. **HEADSET HS-30-( ).** Headset HS-30-( ) is a lightweight, close-fitting headset. Special soft rubber earpieces, fitted to the receivers of the headset, are designed to fit snugly into the ear cavities and exclude outside noises. The headband is a thin steel band that is adjustable to the contours of the operator's head. The clip on the headset cord should be attached to the operator's clothing to relieve the pull of the cord. (See fig. 20.)

b. **CORD CD-874.** Cord CD-874, which terminates in Plug PL-55, is supplied for use with Headset HS-30-( ). The impedance of Headset HS-30-( ) with Cord CD-874 is approximately 250 ohms. Junction Box JB-47 is connected between the headset and Cord CD-874. (See fig. 17.)

### 10. Batteries BA-70 and BA-80

Power is obtained from a single battery secured to the bottom of the set. This battery may be either Battery BA-70 which gives 20 to 25

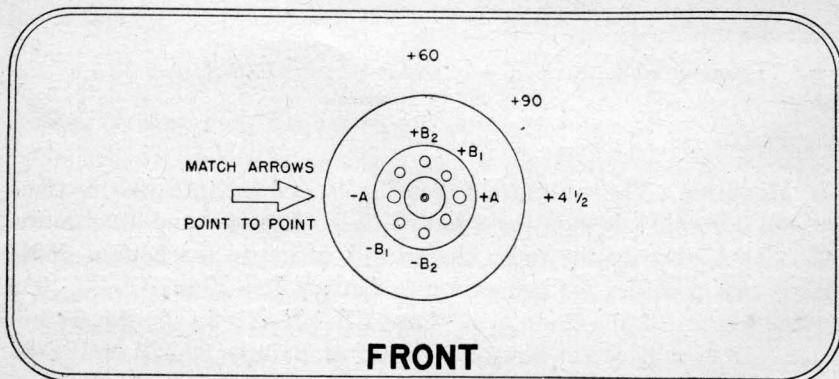

Figure 7. Battery BA-70 or BA-80—top view.

hours of service; or Battery BA-80 which gives 12 to 14 hours of service. These figures apply only in moderate climates. Each battery consists of three dry-battery sections of 4.5 volts, 60 volts, and 90 volts, respectively. (See fig. 7.) The first section supplies the necessary voltage to the microphone circuit and to the filaments of the radio receiver and transmitter. The second and third sections, connected in series, supply 150 volts to the plate circuit of the transmitter. The third section supplies 90 volts to the receiver plate circuits. The battery is electrically connected to the radio chassis by a flexible rubber-covered cable and plug assembly and is fastened with web straps. (See fig. 9.) As has been mentioned, Battery BA-80 is similar to Battery BA-70, differing only in physical size and current capacity. (See table II.) Battery BA-80 is used when extreme portability and lightness of weight are necessary.

## II. Antenna An-130-A

Antenna AN-130-A is a two-section unit which is 33 inches long when assembled. (See fig. 8①.) The sections are held together by a kinkless, stainless steel cable which eliminates the possibility of losing a section and permits rapid assembly of the antenna. The bakelite case at the base of the antenna houses an antenna-matching circuit which consists of a loading coil and a capacitor. The flexible lead with a spade lug, attached to the bakelite shell, must be connected to the binding post marked GROUND FOR SHORT ANT. of Radio Receiver and Transmitter BC-1000-A. This connection is necessary to complete the antenna-matching circuit. A threaded stud is provided at the base of the antenna to attach it to the antenna terminal of the set. A flexible section near the base of the antenna allows the antenna to be bent at an angle so that it can always be adjusted to a vertical position. When not in use, Antenna AN-130-A is carried in Bag BG-150-A.

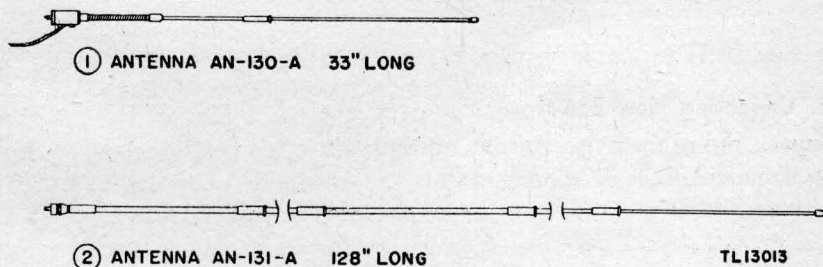

Figure 8. Outline dimensional drawing showing comparison between Antenna AN-130-A and Antenna AN-131-A.

## 12. Antenna AN-131-A

Antenna AN-131-A is a lightweight, tapered, flexible, eight-section antenna which is 10 feet, 8 inches long when assembled. (See fig. 8②.) The eight sections are held together by a kinkless, stainless steel cable which runs the entire length of the antenna and which is under spring tension. This cable not only permits rapid assembly but also eliminates any possibility of losing a section. A threaded stud is provided at the base of the antenna to attach the antenna to the antenna terminal of the set. The GROUND FOR SHORT ANT. binding post is not used with Antenna AN-131-A, since no antenna-matching circuit is required for this antenna. Antenna AN-131-A is designed for use in unobstructed areas only. When not in use, Antenna AN-131-A is carried in Bag BG-150-A.

## 13. Bag BG-150-A (fig. 4)

This is a canvas bag consisting of three compartments; the first for storing Antenna AN-130-A, the second for storing Antenna AN-131-A, and the third for storing Handset TS-15-( ) and Headset HS-30-( ).

## 14. Carrying Accessories

Harness ST-54-A, Belt ST-55-A, and Pad M-391-A, when attached to Radio Set SCR-300-A and Case CS-128-A, provide a means for carrying the set during portable operation. Strap ST-50-A is issued to facilitate lifting or carrying the set by hand. (See fig. 4.)

# Section II. INSTALLATION

## 15. Unpacking New Equipment

Unpack the equipment carefully and inspect it for possible damage during shipment. Check all components against the list indicated in table II to determine if quantities and types are correct. This list is supplied as a guide and should not be used as a basis for issue. Radio Receiver and Transmitter BC-1000-A is shipped with all tubes and crystals installed, and with Case CS-128-A attached. Battery BA-70 or BA-80, Pad M-391-A, Harness ST-54-A, Belt ST-55-A, Strap ST-50-A, Antenna AN-130-A or Antenna AN-131-A, Handset TS-15-( ) and Headset HS-30-( ) are normally used for a complete installation.

## 16. Battery BA-70 or BA-80

a. Release Case CS-128-A by unfastening the six lower clip catch fasteners. The top section of the housing (Radio Receiver and Transmitter BC-1000-A with chassis case) can then be lifted off.

b. Stand the top section of the housing upside down on a bench or on the ground.

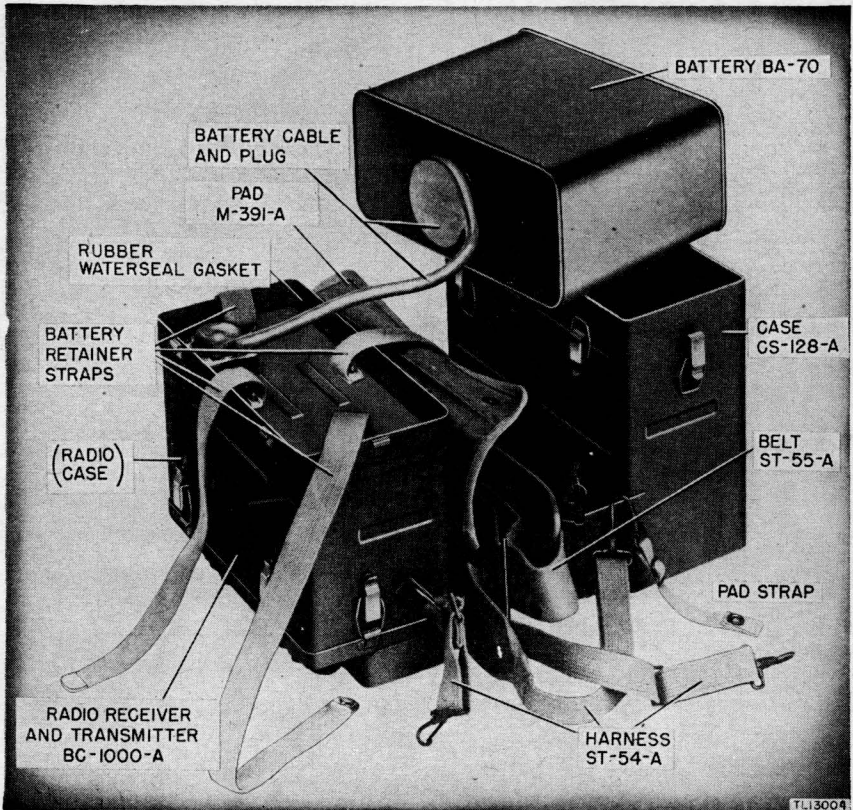

Figure 9. Radio Receiver and Transmitter BC-1000-A, battery cable connected to Battery BA-70—disassembled view.

c. Support the battery on the case as shown in figure 9 and plug the rubber-covered power cable plug into the battery socket so that the arrow on the plug points to the arrow on the battery.

Note. Disregard the word FRONT on Battery BA-70 or BA-80.

d. Lift the battery (with power cable attached) and gently lay it upside down in the middle of the inverted chassis case. The battery cable must lie between the battery and the chassis case in one large loop. The battery must be centered and aligned with the chassis case. (See fig. 10.)

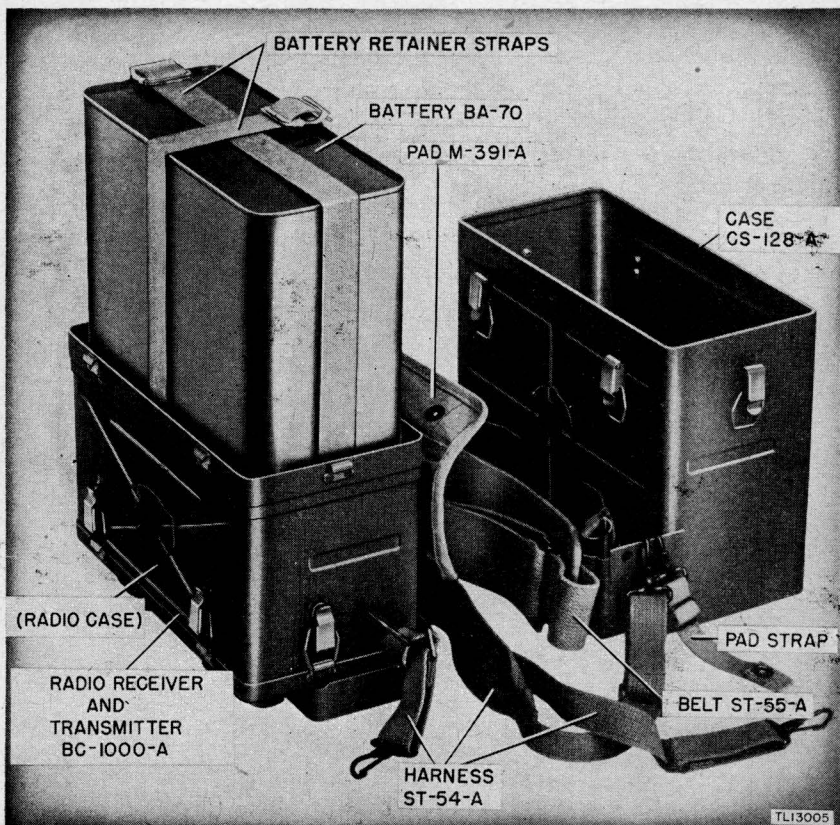

Figure 10: Radio Receiver and Transmitter BC-1000-A, Battery BA-70 in place—disassembled view.

**Caution:** Take care to prevent damage to the flange and waterseal gasket on the chassis case of the radio.

e. Securely fasten the battery to the chassis case with the battery retainer straps as shown in figure 10.

f. Lift the chassis case with the battery attached and lower the battery gently into the battery case. (See fig. 11.)

g. To complete the installation of the battery, fasten the battery case to the chassis case with the six clip catch fasteners.

## 17. Assembly of Carrying Supports

a. PAD M-391-A. This pad has four snap hooks which hold the pad in place on the radio set. Connect the top snap hooks to the pad snap hook brackets near the top of the radio case. Connect the bottom snap hooks on the adjustable straps to the holes nearest the case on the belt carrier bracket. (See fig. 12.) Adjust the slide buckles on the lower straps after installation, so that the pad lies flat against the back of the set housing.



Figure 11. Radio Receiver and Transmitter BC-1000-A, radio set housing assembly after battery installation.

b. BELT ST-55-A. This belt is equipped with two pins permanently attached by short straps. Fasten the belt to the hook brackets with these pins, so that the reinforced eyelet holes are on top. (See fig. 12.)

c. HARNESS ST-54-A. Slip the snap hooks (A) and straps (one each side) through the "D" rings (B) and clip to the center hole (C) of the belt carrier bracket. (See fig. 13.) Attach the other ends (D) of these same straps to the holes (E) (farthest away from the set) of the belt carrier bracket. Be certain that the snaps are not twisted. The other straps (F) with snap hooks are left free until the set is placed on the operator's back. Slide buckles on all straps provide length adjustments as required.

d. STRAP ST-50-A. To install this strap, connect the two snap hooks to the D-rings (B) as shown in figure 13. When it is necessary to

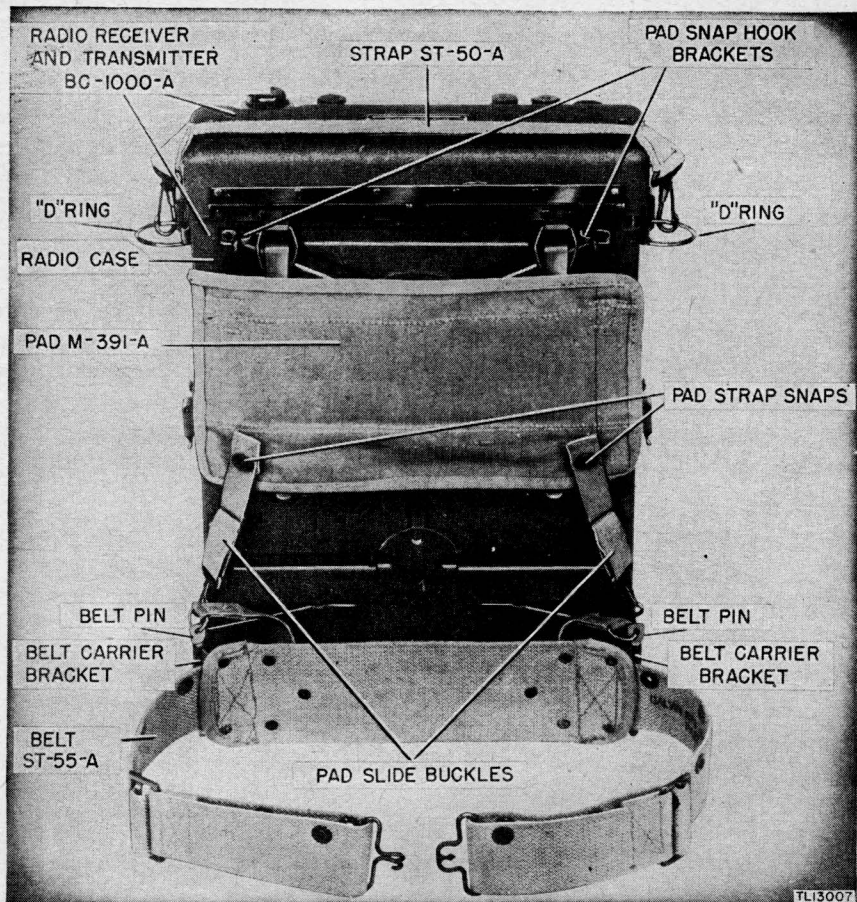

Figure 12. Radio Set SCR-300-A, assembly of Pad M-391-A, Belt ST-55-A, and Strap ST-50-A—rear view.

open the panel cover, the strap is pushed out of the way, toward the back of the set.

e. BAG BG-150-A. Attach Bag BG-150-A to the service belt by inserting the service belt through the two loops on the back of the bag.

## 18. Antennas

This equipment is supplied with two antennas, as described in section I of this chapter. The area in which the set is to operate determines the type of antenna to be used. In clear unobstructed areas, the long antenna is more desirable because it increases the transmitter range. (See fig. 14.) In areas where there are tree branches or other overhead obstructions, use the short antenna. (See fig. 14.) In brief, the longer antenna is more efficient, the shorter antenna easier to handle. Choose the antenna suitable to the situation.



Figure 13. Radio Set SCR-300-A, Harness ST-54-A and Belt ST-55-A, installation detail.



# THESE PLACES ARE BAD FOR RADIO



VALLEYS



HIGH TENSION LINES



OVERHEAD STEEL BRIDGES



UNDERPASSES

# BUT-THESE ARE GOOD



ON LEVEL GROUND



SLIGHT RISE



HIGH HILL

TL 13118

Figure 14. Radio Set SCR-300-A in use, showing good and bad locations.

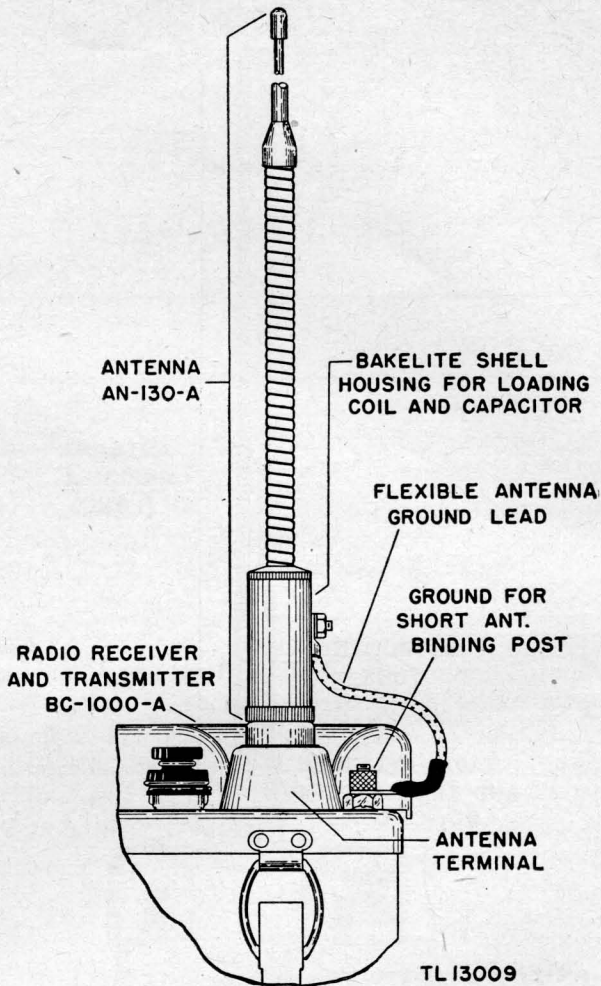

Figure 15. Antenna AN-130-A, installation detail.

*a.* SHORT ANTENNA AN-130-A. (1) Remove the antenna from its case and fit the upper section into the lower.

(2) Screw the assembled antenna into the antenna terminal of the set. Four or five turns should be sufficient. *Do not force.*

(3) Connect the spade lug of the flexible ground lead to the GROUND FOR SHORT ANT. terminal on the front panel. (See fig. 15.)

*b.* TO INSTALL LONG ANTENNA AN-131-A. (1) Unfold the antenna and insert each section carefully into each succeeding section. Start at the top and work toward the base.

**Caution:** In assembling the antenna, avoid shortcuts such as using the built-in spring to snap the antenna into place. Using the antenna like a fishing rod has been found harmful to both spring and inner cable.

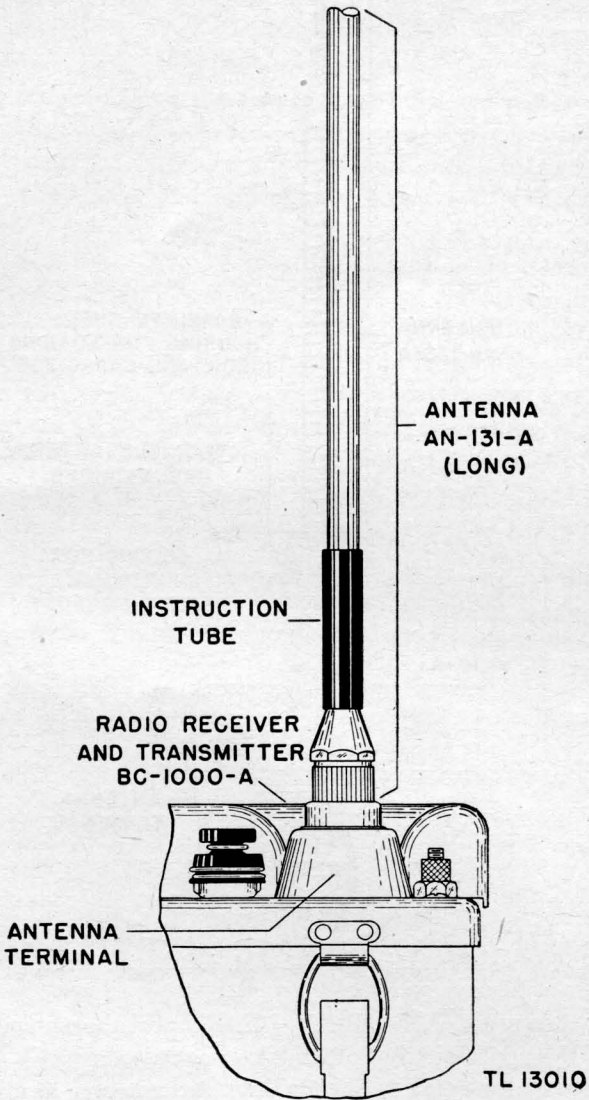

Figure 16. Antenna AN-131-A, installation detail.

(2) Screw the assembled antenna into the antenna terminal just far enough to permit a good connection. This requires approximately five turns. (See fig. 16.) *Do not force.*

*Note.* Antenna AN-131-A is always disassembled by first pulling out, and then folding up the sections. Always start with the top section and work toward the base.

### 19. Handset TS-15-( )

To install the handset, insert Plug PL-68 into MIC. jack and Plug PL-55 into PHONE No. 1 jack.

**Caution:** Unless an antenna is properly connected to the set, do not turn the transmitter on by pressing the receive-transmit switch on Handset TS-15-( ). Failure to heed this precaution will result in damage to the transmitter tubes.

### 20. Headset HS-30-( )

a. CORD-HEADSET CONNECTION. One end of Cord CD-874 terminates in Junction Box JB-47, which is made of two layers of bakelite held together by four screws. (See fig. 17.) Remove these screws with a small screw driver. Inside are four terminals connected in pairs by two metal strips. On the side of one strip is an arrow and the word CORD. Loosen the two end screws nearest this arrow. Connect the white wire from the headset and the white wire from Cord CD-874 to these screws. The remaining colored wires, one from the headset and the other from Cord CD-874, are attached to the screws nearest the arrow marked HEADSET. Lay the heavy insulated cords in the corrugated grooves of the junction box. Fit the two sections of the junction box together snugly. Insert the four screws and tighten firmly into place.

b. CONNECTION TO SET. To connect Headset HS-30-( ), insert Plug PL-55 into AUX. PHONE jack.

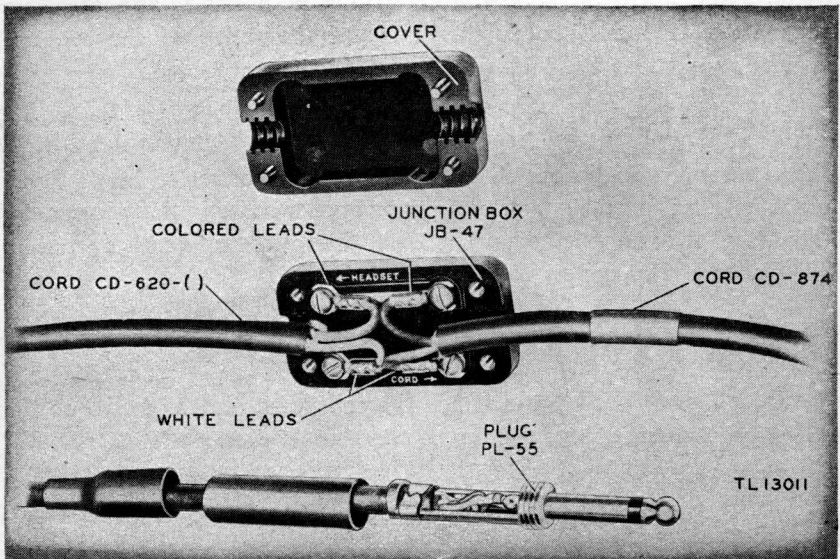

Figure 17. Junction Box JB-47 and Plug PL-55, connection detail.

### Section III. INITIAL ADJUSTMENTS

#### 21. Portable Use of Set

The equipment is mounted on the operator's back (fig. 13) as follows:

- a. Thrust an arm through one shoulder strap and lift the set onto the back. Thrust the other arm through the other shoulder strap.
- b. Hook two ends of Belt ST-55-A together with the hook and clasp.
- c. Adjust the slide buckles of the shoulder straps.
- d. Adjust the cross strap just behind the shoulder to prevent the shoulder straps from slipping off.
- e. Fasten strap  $\text{\textcircled{P}}$ , hanging from the front of the shoulder straps, to Belt ST-55-A. Connect the snap hooks to either the eyeletted holes or the buckles. The set can be carried more comfortably if the straps are adjusted so that the top of the set is slightly above the shoulders and fits snugly to the back.

#### 22. Fixed-Location Use of Set

In a fixed location, mount the set on a table, a stump, the ground, or any convenient object which will support it in an upright position. For best results, avoid as many nearby obstructions as possible, and use long Antenna AN-131-A. To further increase the range of the set, use Antenna Equipment RC-291-( ), when available.

#### 23. Emergency Use of Set

When necessary, Radio Set SCR-300-A may be converted into a light-weight ground portable set, weighing approximately 25 pounds by eliminating all components except those essential to actual operation. (See fig. 18.) Proceed as follows:

- a. Remove Pad M-391-A, Harness ST-54-A, and Belt ST-55-A from the set.
- b. Take Belt ST-55-A and attach the ends with pieces of wire to the D-rings on each side, near the top of the chassis case.
- c. To release Case CS-128-A, unfasten the clip catch fasteners, and lift out the chassis and attached battery.
- d. If Battery BA-70 is attached, stand chassis case upside down, unfasten battery retainer straps, and substitute Battery BA-80.

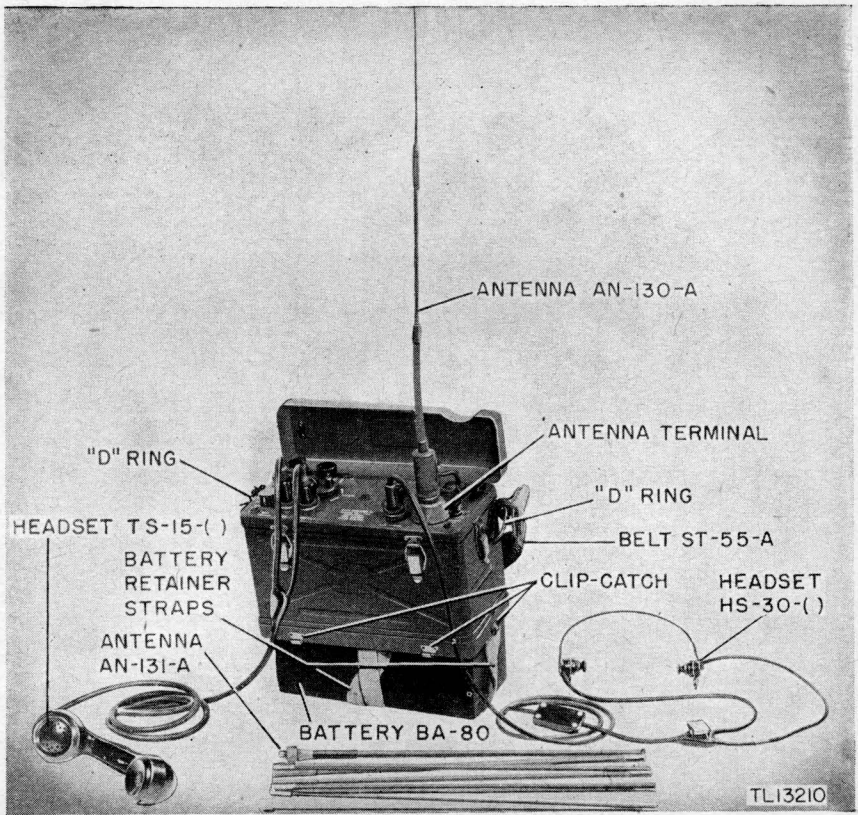

Figure 18. Radio Set SCR-300-A, component parts, lightweight operation.

e. Turn the set upright. Screw Antenna AN-130-A, or Antenna AN-131-A, into the antenna terminal. Attach the ground lead if Antenna AN-130-A is used.

f. Install Handset TS-15-( ) by inserting Plug PL-68 into MIC jack and Plug PL-55 into PHONE No. 1 jack. If Microphone T-45 is used, insert Plug PL-68 of the microphone Cord CD-318 into MIC jack and Plug PL-55 of Headset HS-30-( ) into PHONE No. 1 jack.

g. Lift the set, and put attached Belt ST-55-A over the shoulder, letting the set hang at the left side. (See fig. 19.)

h. The set is now ready to be put into operation.



TL13209

*Figure 19. Radio Set SCR-300-A, lightweight installation.*

## 24. Use of Headset HS-30-( )

Headset HS-30-( ) is used to monitor reception and transmission. It is usually worn by the man who carries the set when two men are using it for portable operation. Wear Headset HS-30-( ) as shown in figure 20. Adjust the position of the phone units and the headband so that the earpieces fit comfortably into the ear cavities. Fasten the clip provided on the cord to the clothing to relieve the pull of the cord.

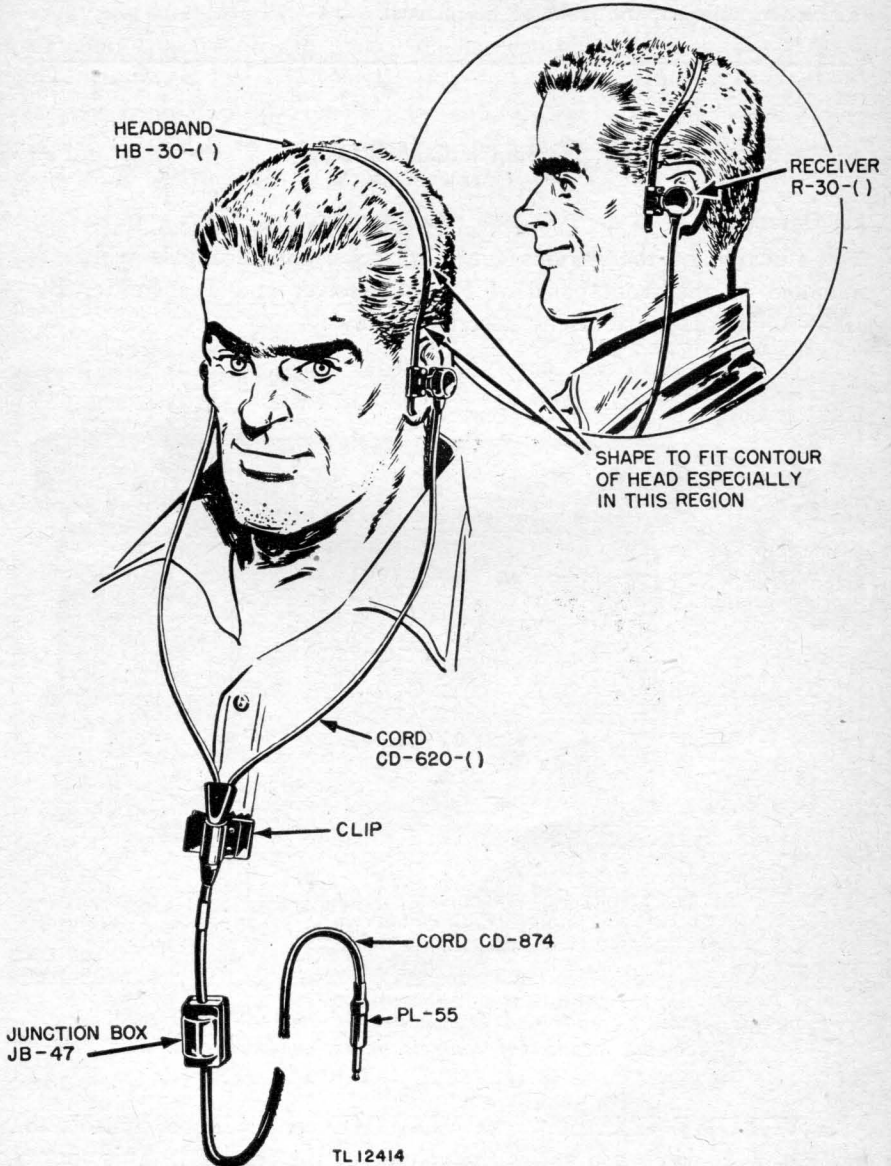

Figure 20. Headset HS-30-( ), in use.



## Chapter 2

# OPERATING INSTRUCTIONS

*Note.* For information on destroying the equipment to prevent enemy use, see destruction notice at the front of the manual.

### Section I. CONTROLS

#### 25. Description

The function of the various controls, jacks, and terminals which are mounted on the front panel of Radio Receiver and Transmitter BC-1000-A (fig. 21), are briefly described below:

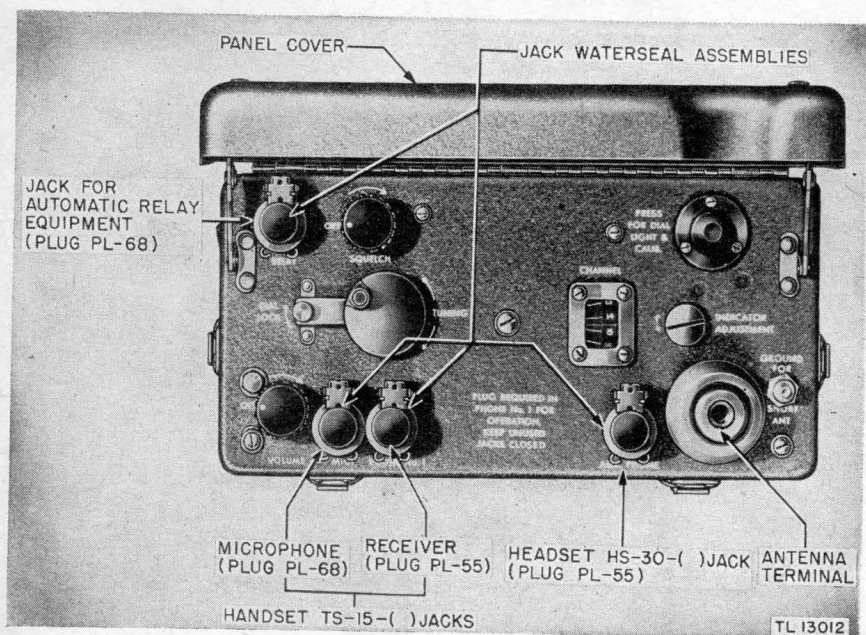

Figure 21. Radio Receiver and Transmitter BC-1000-A—front panel view, showing location of controls, jacks, and terminals.

a. **VOLUME CONTROL.** The **VOLUME** control knob controls the main power switch and varies the volume of the receiver. This control has no effect on the transmitter. The volume control circuit is so designed

that it will allow a signal to be heard faintly with the control turned down completely.

*b. SQUELCH CONTROL.* The SQUELCH control is used to regulate the action of the squelch circuit. It also contains a switch which removes the filament voltage from the squelch tubes when the SQUELCH control is turned to the OFF position.

*c. TUNING, CHANNEL, AND DIAL LOCK.* The set is tuned by turning the knob marked TUNING until the desired frequency channel indication appears directly under the indicator hairline in the CHANNEL window. The CHANNEL dial has been carefully calibrated in channels from 0 to 40, covering a frequency range of 40.0 to 48.0 mc. The DIAL LOCK is a safety device which locks the TUNING knob in place after the operating channel has been selected.

*d. INDICATOR ADJUSTMENT.* The INDICATOR ADJUSTMENT moves the indicator hairline as desired during calibration.

*e. PRESS FOR DIAL LIGHT & CALIB.* When depressed, this button dimly illuminates the dial and produces an audible tone (for calibration) in the headset.

*f. MIC. JACK.* The microphone or MIC. jack provides a connection to the microphone and to the receive-transmit switch of Handset TS-15-( ) (terminates in Plug PL-68).

*g. PHONE No. 1 JACK.* The PHONE No. 1 jack provides a connection for the receiver unit of the Handset TS-15-( ). It also contains an auxiliary safety switch which is connected in series with the main power switch on the VOLUME control.

*Note.* The auxiliary switch is incorporated in the jack marked PHONE No. 1 so that the battery will not become discharged in case the set is put away with the main power switch turned on.

*h. AUX. PHONE JACK.* The AUX. PHONE jack is connected in parallel with the PHONE No. 1 jack and provides a connection for a headset.

*i. RELAY JACK.* The RELAY jack connects the set to other equipment for the reception and retransmission of signals from a remote point.

*j. ANTENNA TERMINAL.* The antenna terminal is an insulated feed-through connector used to connect the radio set to the antenna being used.

*k. GROUND FOR SHORT ANT.* The GROUND FOR SHORT ANT. terminal provides a ground for the flexible antenna grounding lead which is attached to the short Antenna AN-130-A or phantom Antenna A-28-( ).

(5) Set the indicator line directly over the calibration mark C by turning the INDICATOR ADJUSTMENT with a screw driver or coin.

(6) Unlock the TUNING control and set on channel 15. If the set is operating properly, another zero beat will occur at this calibration mark. If the calibration is off, recheck the steps previously outlined. This completes the calibration of the radio set and the channels may now be read directly from the dial.

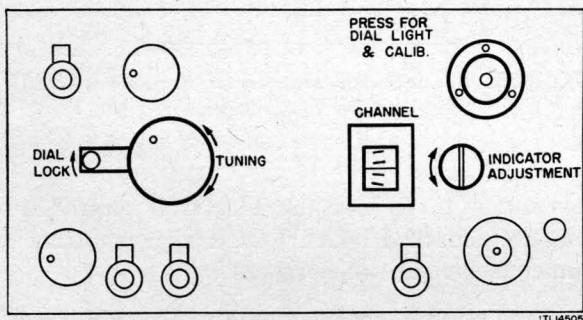

Figure 25. Radio Receiver and Transmitter BC-1000-A, PRESS FOR DIAL LIGHT & CALIB. button.

## 27. Precise Operating Instructions

a. TUNING TO OPERATING CHANNEL. From time to time it may be necessary to change from one operating frequency or channel to another. The CHANNEL dial is divided into 41 channels; the selected channel should be tuned to appear directly under the dial indicator hairline. The frequency difference between each channel is 200 kilocycles (kc), over a frequency range of 40.0 to 48.0 mc (40,000 to 48,000 kc). (See fig. 26.)

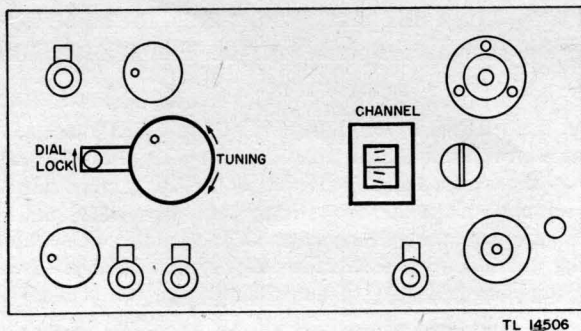

Figure 26. Radio Receiver and Transmitter BC-1000-A, CHANNEL dial.

Table III. Dial calibrations versus frequency

CHANNEL dial marking	Frequency (mc)	CHANNEL dial marking	Frequency (mc)
0	40.0	21	44.2
1	40.2	22	44.4
2	40.4	23	44.6
3	40.6	24	44.8
4	40.8	25	45.0
5	41.0	26	45.2
6	41.2	27	45.4
7	41.4	28	45.6
8	41.6	29	45.8
9	41.8	30	46.0
10	42.0	31	46.2
11	42.2	32	46.4
12	42.4	33	46.6
13	42.6	34	46.8
14	42.8	35	47.0
15-C	43.0	36	47.2
16	43.2	C	47.3
17	43.4	37	47.4
18	43.6	38	47.6
19	43.8	39	47.8
20	44.0	40	48.0

b. DIAL CALIBRATIONS VERSUS FREQUENCY CHART. Use of the above chart is best explained by the following examples:

(1) Desired frequency is 42.4 mc.

(2) Locate 42.4 in the frequency column.

(3) Observe the channel number opposite 42.4 in the CHANNEL column. The position to which the CHANNEL dial should be set for operation on a frequency of 42.4 mc will be channel 12.

(4) After the assigned channel has been selected, lock the TUNING dial control with the DIAL LOCK.

Note. Sometimes it may be necessary to readjust the TUNING control slightly in order to tune to the exact operating channel of the net control station.

c. CONVERTIBLE FREQUENCY INTO CHANNEL NUMBER. To convert a frequency in mc into a channel number, use the following formula:

$$\text{Channel No.} = 5 \times \text{mc} - 200$$

To convert a channel number into a frequency in mc, use the following formula:

$$\text{Mc} = 0.2 \text{ Channel No.} + 40$$

d. TO RECEIVE. Upon completion of the above instructions, Radio Set SCR-300-A is ready to receive signals. The audio output of the receiver to the handset or headset is regulated by varying the VOLUME control until the desired audio level is attained.

e. ADJUSTMENT OF SQUELCH CONTROL. If it is desired to use the squelch circuit to eliminate noise when no signal is being received, adjust the SQUELCH control as follows:

(1) Turn the SQUELCH control knob to the right until a click is heard. Allow 2 or 3 minutes for a warm-up period.

(2) Continue to turn the knob to the point where the noise disappears.

**Caution:** Do not turn the SQUELCH control beyond the point where the noise is eliminated, or the weaker signals will not be heard. If the automatic relay equipment is used, check the adjustment of the SQUELCH control carefully and frequently because of possible interaction between the SQUELCH control and the VOLUME control.

(3) If squelch action is not needed in normal operation, keep the SQUELCH control turned to the OFF position. This will help to conserve the battery.

f. To TRANSMIT. To put the transmitter in operation, press the receive-transmit switch in the handle of Handset TS-15-( ), and speak in a normal, clear voice directly into the microphone.

## 28. Stopping Procedure

a. SQUELCH CONTROL. Turn the SQUELCH control to the OFF position before turning off the rest of the set. This provides an opportunity to check the final squelch operation, judge the signal-to-noise ratio, and check the over-all performance at the conclusion of operation. See equipment performance check list, paragraph 30.

b. VOLUME CONTROL. Now, turn the VOLUME control to the OFF position (full left). A click (the power switch) should be heard, denoting that the set has been turned off.

c. ANTENNA AND HANDSET. Detach the antenna and handset, and also the headset, if used. At this time observe the condition of the handset, headset, antenna, and the antenna insulator. Close the jack water-seals. Defects noted at this time should be corrected before the next scheduled operation.

## 29. General Operating Precautions

The operation of Radio Set SCR-300-A is basically simple. Familiarity will come with continued use. *Remember the following points:*

a. Speak close to the microphone in a clear voice. Do not talk across or away from the microphone. Do not shout when transmitting.

b. Do not operate with antenna in horizontal position. (See fig. 27.) *Keep your antenna vertical.* It functions more efficiently in this position.

c. Adjust the SQUELCH control properly. Use as little of the squelch as possible; the less the better. Improper use (too much) reduces the sensitivity of the set and weak signals will be lost.

d. Turn the SQUELCH control to the OFF position if the squelch action is not needed. This will help to prolong the life of the battery.

e. Keep transmissions short. The enemy may plot your position with a direction finder.



Figure 27. Do not operate with the antenna horizontal; keep it vertical.

- f.* Keep the jacks sealed when not in use. This keeps moisture out.
- g.* Do not press the PRESS FOR DIAL LIGHT & CALIB. button when transmitting. The filament of the transmitter mixer tube V2 will burn out.
- h.* Do not attempt to transmit unless an antenna is properly installed and connected. Failure to heed this will result in damage to the transmitting tubes.
- i.* Do not let antenna touch branches or other surrounding objects. This will reduce the range of the radio set. (See fig. 28.) (See FM 24-18.)
- j.* Do not forget the battery. Check it frequently.
- k.* Be certain to turn the VOLUME control to the OFF position when the set is not in use.
- l.* If relay equipment is used, double check adjustment of the SQUELCH control.

*m.* Above all, handle the set carefully. Although ruggedly built, this is a precision instrument and requires good treatment in order to be accurate and reliable.



Figure 28. Do not let antenna touch branches or other surrounding objects.

### Section III. EQUIPMENT PERFORMANCE CHECK LIST

#### 30. Purpose and Use of Check List

*a.* GENERAL. The equipment performance check list (table IV) will help the operator to determine whether Radio Set SCR-300-A is functioning properly. The check list gives the item to be checked, the condition under which the item is checked, the normal indications and tolerances of correct operations, and the corrective measures that the operator can take. Items 1 and 2 are checked before starting, Items 3 and 4 when starting, Items 5 to 9 during operation, and Items 10 to 12 when stopping. Items 5 to 9 on this check list should be checked at least once during a normal operating period or at least four times a day during continuous operation.

*b.* ACTION OR CONDITION. For some items the information given in the action or condition column consists of the settings of various switches

and controls under which the item is to be checked. For other items it represents an action that must be taken in order to check the normal indication given in the normal indication column.

*c. NORMAL INDICATIONS.* The normal indications include the visible and audible signs that the operator will perceive when he checks the items. If the indications are not normal, the operator should apply the recommended corrective measures.

*d. CORRECTIVE MEASURES.* The corrective measures listed are those that the operator can make without turning the equipment in for repairs. If the set is completely inoperative or if the recommended corrective measures do not yield results, trouble shooting is necessary. However, if the tactical situation requires that communication be maintained and if the set is not completely inoperative, the operator must maintain the set in operation as long as it is possible to do so.



Table IV. Equipment performance check list

	No.	Item	Action or condition	Normal indications	Corrective measures
PREPARATORY	1	Antennas AN-130-A and AN-131-A.	Assemble antenna. Screw antenna into terminal.	Sections fit together snugly. Base of antenna fits snugly against top of terminal.	Replace antenna. Clean threads of antenna base and terminal.
	2	Antenna AN-130-A.	Connect flexible ground lead to GROUND FOR SHORT ANT. terminal.	Terminal holds spade lug firmly.	Replace flexible ground lead.
START	3	VOLUME control.	Turn control clockwise from OFF position.	Click is heard in handset.	Insert Plug PL-55 securely into PHONE No. 1 jack, and Plug PL-68 securely into MIC jack. Replace handset.
	4	Warm-up period.	Set turned on.	Rushing noise heard in handset after few seconds.	Turn SQUELCH OFF.
EQUIPMENT PERFORMANCE	5	PRESS FOR DIAL LIGHT & CALIB. button.	Press button.	CHANNEL dial dimly illuminated.	Replace dial lamp. (See par. 107.)
	6	TUNING control.	Tune to calibration marks, C.	Beat note is heard.	Adjust INDICATOR ADJUSTMENT. (See par. 26d.)
			Rotate knob.	Knob moves freely in either direction.	Loosen DIAL LOCK. (See par. 26d.)
7	SQUELCH control.	Tune to signal.	Rushing noise ceases; signal is heard.	Place antenna in vertical position. Replace battery. (See par. 108.)	
		Check CHANNEL number of received signal.	Signal is heard on correct CHANNEL.	Recalibrate as in step 5 above.	
			Turn control a few degrees clockwise from OFF. Continue rotation of control.	Click is heard in handset; rushing noise continues. Rushing noise in handset ceases.	Check SQUELCH control knob for position. Replace battery.

	No.	Item	Action or condition	Normal indications	Corrective measures	
EQUIPMENT PERFORMANCE	8	Handset TS-15-( ).	Tune to signal.	Signal is heard clearly.	Turn in set for repairs. Check setting of SQUELCH control.	
			Received signal ceases.	Receiver quiets after short burst of noise.	Check setting of SQUELCH control.	
			Plug PL-55 securely inserted into PHONE No. 1 jack; Plug PL-68 securely inserted into MIC jack.			
			Flex cord throughout its entire length.	No change in handset output.	Replace cord	
		Receive-transmit switch in transmit position.	Receiver quiets.	Replace handset.		
		Speak into microphone while transmitting.	Small amount of sidetone is heard.	Replace handset.		
	9	Headset HS-30-( ).	Plug PL-55 securely inserted into AUX phone jack.			
		Turn SQUELCH OFF.	Rushing noise is heard.	Replace cord.		
		Flex cord throughout its entire length.	No change in handset output.	Replace headset. Replace cord.		
STOP	10	SQUELCH control.	Turn to OFF.	Rushing noise heard in headset.	Replace battery. (See par. 108.)	
	11	VOLUME control.	Rotate counter-clockwise.	Volume level decreases gradually.	Turn in set for repair.	
			Turn to OFF.	Volume level decreases to zero after click is heard.	Turn in set for repair.	
	12	Antennas.	Disassemble and fold sections.	No kinks in steel cable.	Replace antenna.	

## Chapter 3

# PREVENTIVE MAINTENANCE

---

### Section I. PREVENTIVE MAINTENANCE TECHNIQUES

#### 31. Meaning of Preventive Maintenance

Preventive maintenance is a systematic series of operations performed at regular intervals on equipment, when turned off, to eliminate major breakdowns and unwanted interruptions in service, and to keep the equipment operating at top efficiency. To understand what is meant by preventive maintenance, it is necessary to distinguish between preventive maintenance, trouble shooting, and repair. The prime function of preventive maintenance is to *prevent* break-downs and, therefore, the need for repair. On the other hand, the prime function of trouble shooting and repair is to locate and correct *existing* defects. The importance of preventive maintenance cannot be overemphasized. The entire system of radio communication depends on each set's being *on the air* when it is needed and upon its *operating efficiency*. It is vitally important that radio operators and repairman maintain their radio sets properly.

*Note.* The operations in this section are considered first and second echelon (organization operators and repairman) maintenance.

#### 32. Description of Preventive Maintenance Techniques

*a. GENERAL.* Most of the electrical parts used in Radio Set SCR-300-A require routine preventive maintenance. Those requiring maintenance differ in the amount and kind required. Because hit-or-miss maintenance techniques cannot be applied, definite and specific instructions are needed. This section of the manual contains those specific instructions and serves as a guide for personnel assigned to perform the six basic maintenance operations: Feel, Inspect, Tighten, Clean, Adjust, and Lubricate. Throughout this manual the lettering system for the six basic operations will be as follows:

F—Feel.

I—Inspect.

T—Tighten.

C—Clean.

A—Adjust

L—Lubricate.

The first two operations establish the need for the other four. The selection of operations is based on a general knowledge of field needs. For example, the dust encountered on dirt roads during cross-country travel filters into the equipment no matter how much care is taken to prevent it. Rapid changes in weather (heavy rain followed by blistering heat), excessive dampness, snow, and ice tend to cause corrosion of exposed metal parts. Without frequent inspections and the necessary performance of tightening, cleaning, and lubricating operations, equipment becomes undependable and subject to break-down when it is most needed.

*b. FEEL.* The feel operation is used most often to check rotating machinery, such as blower motors, drive motors, etc., and to determine if electrical connections, bushings, etc., are overheated. Feeling indicates the need for lubrication or the existence of similar types of defects requiring connection. The maintenance man must become familiar with the normal operating temperatures of motors, etc., in order to recognize signs of overheating.

*Note.* It is important that the feel operation be performed as soon as possible after shut-down and always before any maintenance is done.

*c. INSPECT.* Inspection is the most important operation in the preventive maintenance program. A careless observer will overlook the evidences of minor trouble. Although these defects may not interfere with the performance of the equipment, valuable time and effort can be saved if they are corrected before they lead to major break-downs. Make every effort to become thoroughly familiar with the indications of normal functioning, in order to be able to recognize the signs of a defective set. Inspection consists of carefully observing all parts of the equipment, noticing their color, placement, state of cleanliness, etc. Inspect for the following conditions:

(1) Overheating, as indicated by discoloration, blistering, or bulging of the parts or surfaces of the container; leakage of insulating compounds; and oxidation of metal contact surfaces.

(2) Placement, by observing that all leads and cabling are in their original positions.

(3) Cleanliness, by carefully examining all recesses in the units for accumulation of dust, especially between connecting terminals. Parts, connections, and joints should be free of dust, corrosion, and other foreign matter. In tropical and high-humidity locations, look for fungus growth and mildew.

(4) Tightness, by testing any connection or mounting which appears to be loose.

*d.* **TIGHTEN, CLEAN, AND ADJUST.** These operations are self-explanatory. Specific procedures to be followed in performing them are given wherever necessary throughout part three.

**Caution:** Screws, bolts, and nuts should not be tightened carelessly. Fittings tightened beyond the pressure for which they are designed will be damaged or broken.

Whenever a loose connection is tightened, it should be moistureproofed and fungiproofed again by applying the varnish with a small brush. See section IV for details of moistureproofing and fungiproofing.

*e.* **LUBRICATE.** Lubrication refers to the application of grease or oil to the bearings of motors or other rotating shafts. It may also mean the application of a light oil to door hinges or other sliding surfaces on the equipment.

## Section II. ITEMIZED PREVENTIVE MAINTENANCE

### 33. General

For ease and efficiency of performance, preventive maintenance services on Radio Set SCR-300-A will be broken down into operations that can be performed at different time intervals. In this section the preventive maintenance work to be performed on the radio set at specified time intervals is broken down into units of work called items. The general techniques involved and the application of the FITCAL operations in performing preventive maintenance on individual parts are discussed in the following paragraphs. These general instructions apply throughout the remainder of this section. All work is to be performed with the power removed from the equipment except where otherwise specified. After preventive maintenance has been performed on a given day, the equipment should be put into operation and checked for satisfactory performance. (See paragraph 30.) If preventive maintenance operations disclose that repairs or parts replacement call for higher echelon maintenance, accomplish this through normal repair channels

### 34. Common Materials Needed

The following items will be needed in performing preventive maintenance:

- Common hand tools (TE-41 or equivalent).
- Clean soft rags.
- Soap.
- Water.
- Camel's-hair brush.
- Metal polish.

Emery cloth.

No. 0000 sandpaper.

Screw driver (long-shaft, small).

Set of wrenches (3/16 to 1/2 inch).

Allen setscrew wrench.

Test equipment as indicated in paragraphs on tubes, batteries, and alignment voltage measurements.

OE, oil, engine, SAE No. 10, U. S. Army Spec No. 2-104B.

GL, grease, lubricating, special, Ordnance Spec No. AXS-637.

SD, solvent, dry-cleaning, Federal Spec. No. P-S-661a.

*Note.* Gasoline will not be used as a cleaning fluid for any purpose. Solvent, dry-cleaning, Federal Spec No. P-S-661a, is available as a cleaning fluid, through established supply channels. Oil, fuel, Diesel, U. S. Army Spec. No. 2-102B, may be used for cleaning purposes when dry-cleaning solvent is not at hand. Carbon tetrachloride, or fire-extinguishing liquid (carbon tetrachloride base), will be used, if necessary, *only on contact surfaces of electronic equipment.*

### 35. Front of Operating Panel, Items 1, 2, 3, 4, and 5 (fig. 21)

a. INSPECT, ITEM 1. Check the paint for scratches, chips, and blisters. Check for dents, cuts, or bends in panel. The hinged panel cover should fit tightly, and its hinge and hinge springs, as well as the snap bracket mountings should be in good mechanical condition.

(1) *Controls, Item 2.* Check controls and switches for proper operation. Have all knobs and handles that are chipped or broken, replaced. Markings on knobs should indicate position correctly. Check the following:

(a) SQUELCH control and switch.

(b) VOLUME control and switch.

(c) TUNING control (DIAL LOCK should lock TUNING dial effectively).

(d) INDICATOR ADJUSTMENT control should move red line on CHANNEL dial window with aid of screw driver or coin.

(2) *Jack waterseal assemblies, Item 3.* These assemblies should be mechanically sound. Have all rubber seals that are cracked or chipped replaced. Check:

(a) RELAY jack.

(b) MIC. jack.

(c) PHONE No. 1 jack.

(d) AUX. PHONE jack.

(3) *Bushings, Item 4.* Inspect bushings for cracks, stripped threads, or chips, and have replaced if necessary. Check:

(a) Antenna terminal bushing.

(b) GROUND FOR SHORT ANT. terminal.

b. TIGHTEN. Tighten all mounting screws, bolts, and rivets when necessary, be careful not to burr bolts and injure grooves.

c. CLEAN. Remove all dirt, dust, fungi, or other foreign matter. Use dry-cleaning solvent on exposed metal parts. On painted parts use a damp cloth.

d. ADJUST. Adjust position of knobs to indicate OFF position by aligning the dot on knob with word OFF on the panel.

e. LUBRICATE, ITEM 5. See paragraph 45a(1).

### 36. Antennas, Items 6 and 7

a. INSPECT, ITEM 6. Inspect the general condition of both short and long antennas. Check for physical damage and chipped or blistered paint. Inspect the cables inside the mast sections for broken strands, knots, or kinks. Be certain that all mast sections joints fit into place snugly. Check the threaded studs at the base of the antennas for stripped threads. Specific items to be inspected for each of the antennas follow:

(1) *Antenna AN-130-A*. (a) Make certain that the flexible section near the base of the antenna bends readily and is not broken.

(b) Make certain that the bakelite shell housing for the antenna-loading circuit at the antenna base is in good physical condition.

(c) See that the ground lead is tightly bolted to the bakelite housing and the spade lug well-grounded to the ground lead.

(2) *Antenna AN-131-A, Item 7*. Inspect for proper tension the spring to which the cable is attached and make certain that the small tip on the top end is secure when the antenna sections are in place.

b. TIGHTEN. Tighten tip and base sections of Antenna AN-131-A when necessary.

c. CLEAN. Remove all dust, dirt, and other foreign matter from all parts. Use dry-cleaning solvent on exposed metal parts. On painted parts use a damp cloth.

### 37. Handset and Headset, Items 8 and 9

a. INSPECT, ITEM 8. Inspect the general condition of the handset and headset. Inspect all cords for kinks, knots, cuts, and burns. It is important to check points where cords enter headset, handset, or plugs. These molded sections and covers receive the most wear. The plugs should be in good physical condition with no cracks in insulation between conductors or in the sleeve. Specifically check:

(1) *Handset*. (a) Check switch for smooth operation and be certain the mounting screws are tight.

(b) Inspect the earphone and microphone covers for defects, and replace if necessary.

(2) *Headset*. (a) See that the rubber inserts are *live* and in good physical condition. Replace with new inserts if rubber becomes hard.

(b) Check the operation of the breast clamp.

(c) Check Junction Box JB-47. The four screws should be tight; the box clean and mechanically sound.

b. TIGHTEN. Tighten any loose sleeve of a phone plug by *hand* only. When necessary, tighten the screws holding the cover on Junction Box JB-47, or the switch mounting screws on Handset TS-15-( ).

c. CLEAN. Clean the headset, handset, junction box, breast clamp, plugs, and cords with a clean, slightly moistened cloth. Wipe thoroughly. Polish brass portions of the plugs with metal polish. Make certain the brass portions of the plugs are bright with no indication of corrosion.

d. LUBRICATE, ITEM 9. See paragraph 45a.

### 38. Top of Chassis, Items 10, 11, 12, and 13

a. INSPECT, ITEM 10. Check the general physical condition of the top of the chassis. Make sure there are no dents and breaks in the chassis or mounted parts. Also check for loose connections and broken leads. Inspect the wiring and solder joints for *shorts* to the chassis or any near-by parts. The dial light assembly should be firmly clipped to its bracket and the bulb secure in the socket. Inspect the following parts carefully:

(1) *Tube shields and tubes, Item 11.* Make certain the tube shields are securely locked in place and the springs in good condition with enough tension to hold each tube firmly in its socket. If, during the inspection, a *milky* discoloration is noted at the top of any tube, replace the tube. This condition should not be confused with the *getter* coating on the wall of the tube. The tubes used in Radio Set SCR-300-A are fragile and must be handled carefully. Never move a tube from side to side to check socket tightness. Inspect the physical condition of the tube sockets. For further information on checking and replacing tubes, see paragraph 104.

(2) *Transformer shields.* Inspect the shields for secure mounting and good physical condition. Inspect the mounting nuts and lockwashers for tightness. Make sure the locknuts hold the adjusting screw securely.

(3) *Tuning capacitor and gear assembly, Item 12.* Inspect the gear teeth on the assembly at the capacitor and on the calibration dial. Have the gear replaced if the teeth are badly worn or broken. The springs on the anti-backlash gears must be tight and in good physical condition.

(4) *Crystal units, Item 13.* Make certain the crystal units are held firmly in place by their clamps. Inspect the crystal holders for chips, cracks, and have replaced if necessary.

(5) *Switch.* Make certain switch SW3 is not bent or sprung and that the insulated part is in good physical condition.

(6) *Jack waterseals.* Inspect the cover of the waterseals for cuts, cracks, or breaks. Have replaced if necessary.



(7) *Power plug and test receptacle.* Check to see that the plug and receptacle are in good physical condition; that the pins of the plug are straight and tight; and that the insulation is not chipped or broken. Both plug and receptacle must be mounted securely.

b. TIGHTEN. Tighten all locknuts, tube shield base screws, and all mounting nuts and screws when necessary.

**Caution:** Do not touch adjusting screws on any of the transformers.

c. CLEAN. Remove all dust, lint, etc., with a soft brush. Remove oil and grease with a soft cloth dampened with dry-cleaning solvent. Clean all tubes, tube pins, tube shields, transformer shields, and power plug pins with a soft cloth dampened with dry-cleaning solvent.

d. LUBRICATE, ITEM 12. See paragraph 45b(2).

### 39. Bottom of Chassis, Item 14

a. INSPECT. Make a general overall inspection of the chassis. Check carefully for loose or broken leads and poorly-soldered or loose connections to soldering lugs. Inspect carefully:

(1) *Resistors, capacitors, and chokes.* Resistors, capacitors, and chokes should not be burned, cracked, or blistered.

**Caution:** When inspecting resistors, capacitors, and chokes, be careful not to break leads and connections.

(2) *Soldering terminal boards, lugs, and tube sockets.* Check to see that all soldering terminal boards, lugs, and tube sockets are securely fastened, and that all leads and connections are well isolated, and that the insulation is in good condition.

(3) *Jack waterseals.* Inspect the rubber waterseals for cuts, cracks, tears, or burnt spots, and have replaced if necessary.

(4) *Coil forms.* Inspect the coils for shorts and open circuits, and make certain the forms are securely attached to the chassis and free from breaks and cracks.

(5) *Variable capacitors.* Inspect the small trimmer capacitors for dented or bent plates.

**Caution:** The position of these capacitors should not be altered.

(6) *Antenna terminal insulator.* The braided antenna lead to the antenna terminal must not be twisted or shorted.

b. TIGHTEN. Tighten all nuts and screws when necessary.

c. CLEAN. Remove all dust, rust, and other foreign matter from parts attached to the chassis and from the chassis. Use a camel's-hair brush. In smaller spaces a cloth dampened with dry-cleaning solvent and wound around a thin screw driver can be used.

#### 40. Battery, Battery Cable, and Connectors, Items 15 and 16

a. INSPECT. (1) *Item 15.* Check the battery receptacle and replace if it is cracked or broken. Check battery cable for deterioration of rubber, excess wear, cuts, and kinks. Replace if necessary. Devote special attention to junction points and connectors.

(2) *Item 16.* Check the condition of Battery BA-70 or BA-80 by observing the relative brightness of the dial lamp. A light dimmer than normal indicates a run-down battery. Check transmission with a second set, but do so *only if transmissions are authorized.* Poor transmission may indicate a run-down battery. For an exact check of the battery, take it to a second echelon repairman, or arrange for this check through the communication officer or communication chief.

b. TIGHTEN. When necessary, tighten the nuts which hold the battery receptacle in place.

c. CLEAN. Clean connectors and pins with a cloth, or, if necessary, with metal polish or emery cloth. If metal polish is used, remove all residue of the polish after cleaning operation in order to maintain good contact. Remove grease and oil from the cable or associated parts with a soft rag dampened with dry-cleaning solvent.

#### 41. Cases and Carriers, Item 17

a. INSPECT. Check cases both inside and outside. Inspect for dents, cuts and deep scratches; repair if necessary. Case edges should be smooth, not bent or broken. Be certain good contact is made with water-seal gaskets. Inspect the webbing of carriers for frayed or broken strands, and replace if necessary. Check the following parts carefully:

(1) *Waterseal gaskets.* Inspect the rubber in these gaskets for cuts and cracks, and have replaced if necessary. It should be evenly placed in the grooves.

(2) *Clip-catch assemblies.* Check the condition of the fasteners; they should be securely fastened to the case.

(3) *Metal accessories (Buckles, pins, etc.).* Check all metal parts for proper operation. They should work (lock, etc.) easily and securely.

(4) *Rivets.* Inspect all rivets for breaks or burns, and have replaced if necessary.

b. TIGHTEN. Tighten all nuts attaching accessories to chassis.

c. CLEAN. Use dry-cleaning solvent to clean metal parts. Clean web equipment with soap and water. Dry thoroughly.

#### 42. Checking Alignment, Item 18

In checking the alignment of Radio Receiver and Transmitter BC-1000-A, certain voltage measurements must be taken. These voltages are measured at the metering socket SO1 with an electronic voltmeter or Alignment Indicator I-210-(M) (VTVI) which is furnished to organ-

izational personnel with Maintenance Equipment ME-40-( ).

*a.* Remove the chassis from the case and plug into Battery BA-70 or BA-80.

*b.* Turn the VOLUME control to the maximum clockwise position and the SQUELCH control to the maximum counterclockwise position. A loud rushing noise should be heard in the headset and handset. Tuning from channel No. 0 to channel No. 40 should cause neither an increase nor decrease of rushing noise.

*c.* The following voltages should be present between the metering socket pins and chassis with the receive-transmit switch in the indicated position.

*Note.* There should be little or no change in the readings when tuning from channel No. 0 to channel No. 40.

<i>Pin No.</i>	<i>Volts</i>	<i>Position of receive-transmit switch</i>
1.....	— 5.5 to —10	R o T
2.....	— 0.5 to — 1.5	R
3.....	— 6.0 to —15	R
4.....	—18 to —45	R
5.....	—12 to —20	T
6.....	—25 to —40	T
7.....	0 to $\pm$ 0.5	R
8.....	Ground	

Incorrect readings at these pin jacks indicate the necessity for realigning the radio set. See section XVIII for correct alignment procedures.

### 43. Preventive Maintenance Check List

The following check list is a summary of the preventive maintenance operations to be performed on Radio Set SCR-300-A. The time intervals shown on the check list may be reduced at any time by the local commander.

*a. BEFORE OPERATION.* The before operation column shows checks to be made before Radio SCR-300-A is put into operation. Checks should be made sufficiently before the actual time of use to permit minor repairs or equipment substitution before operations start.

*b. DAILY.* Perform daily checks when the equipment is used normally. If the set is in storage, however, check it only occasionally.

*c. AFTER OPERATION.* These checks are performed immediately after the equipment is shut down following normal operating periods. It is not necessary to perform them following very short periods of operation unless there is an indication of improper performance.

*d. WEEKLY.* Weekly checks must be performed on equipment assigned to a using unit, whether or not the set is in actual operation.

e. MONTHLY. Monthly checks must be performed on equipment assigned to a using unit regardless of the number of hours of operation.

f. ECHELON. The echelon column indicates which operations are considered first echelon maintenance and which operations are considered second echelon maintenance.

Table V. Preventive maintenance check list

Item No.	Operations	Item	When performed					Echelon
			Before operation	After operation	Daily	Weekly	Monthly	
1	ITCAL	Front operating panel (par. 35)			X			1st
2	ITCA	Controls (par. 35a(1))					X	1st
3	ITC	Jack waterseal assemblies (par. 35a(2)).					X	1st
4	ITC	Bushings (par. 35a(3)).					X	1st
5	ICL	Panel cover hinge, springs, and snap bracket mountings (par. 35e).					X	1st
6	ITC	Antennas (par. 36)	X	X	X			1st
7	T	Tip and base sections of Antenna AN-131-A (par. 36a(2)).					X	1st
8	ITC	Handset and headset (par. 37).			X			1st
9	ICL	Metal part of headband on headset (par. 37d).					X	1st
10	ITC	Top of chassis (par. 38).					X	1st
11	I	Inspect tubes (par. 38a(1)).					X	1st
	F	I	T	C	A	L		
	Feel	Inspect	Tighten	Clean	Adjust	Lubricate		

Table V. Preventive maintenance check list

Item No.	Operations	Item	When performed					Echelon
			Before operation	After operation	Daily	Weekly	Monthly	
12	ICL	Tuning capacitor and gear assembly (par. 38a(3) and par. 38d).					X	1st
13	IC	Crystal units (par. 38a(4)).					X	1st
14	ITC	Bottom of chassis (par. 39).				X		1st
15	ITC	Battery, battery cable (par. 40).	X	X	X			1st
16	I	Voltage measurements (par. 40a(1)).		X	X			1st
17	ITC	Cases and carriers (par. 41).			X			1st
18	I	Check alignment (par. 42).				X		2nd
	F	I	T	C	A	L		
	Feel	Inspect	Tighten	Clean	Adjust	Lubricate		

#### 44. Factors Determining Preventive Maintenance Periods

a. USE. If field operations require use of the equipment for periods longer than the normal periods (4 hours daily) more frequent checks should be scheduled. This applies especially to equipment in combat areas.

b. THEATER. The weather and climatic conditions of the theater in which unit is being used also determine how often the set should be checked. Some of the climatic conditions that should be considered are:

(1) *High ambient temperature.* Extremely hot weather accompanied by high humidity requires more frequent alignment. The set should be dried out often to avoid fungi growth and insulation failures. Although the set has been processed with moistureproofing and fungiproofing varnish, the moisture can still form. However, the condition of the varnish should be checked frequently and the date of the last MFP treatment should be noted. If necessary, the set should be retreated as outlined in section IV.

(2) *Extreme cold and high humidity.* Extreme cold causes lubricants to thicken. With high humidity, moisture seeps into the set when the temperature rises. When the temperature falls, the moisture freezes.

Inspect the set more often in areas where there are frequent and extreme changes in weather conditions.

c. PERFORMANCE. If the over-all performance of Radio Set SCR-300-A falls below normal sooner than checks are scheduled, additional checks should be made. If this occurs on all or many sets in an area, more frequent checks should be scheduled.

### Section III. LUBRICATION

#### 45. Lubrication

No War Department Lubrication Order is prescribed for Radio Set SCR-300-A, but in the preventive maintenance check list in this manual certain parts are recommended for lubrication to prolong their life.

a. HEADSET. To prevent rust from forming on the metal parts of the head-band, a *thin* coat of OE, oil, engine, SAE-10, U. S. Army Specification No. 2-104-B should be applied weekly.

b. PANEL COVER HINGE, HINGE SPRINGS, AND BRACKET MOUNTINGS. Apply a thin film of engine oil (OE SAE No. 10) monthly.

c. TUNING CAPACITOR GEAR ASSEMBLY. Apply engine oil (OE SAE No. 10) *sparingly* to ball bearing, and a small amount of GL, grease, lubricating, special, Ordnance Specification No. AXS-637 to the gear assembly.

### Section IV. MOISTUREPROOFING AND FUNGIPROOFING

#### 46. Problems Encountered

Signal Corps equipment operated in tropical areas where temperature and relative humidity are extremely high requires special attention. The following problems may be encountered during operation:

- a. Failure of resistors, coils, chokes, or transformer windings.
- b. Break down of resistors, coils, chokes, transformer windings caused by electrolytic action.
- c. Flash-overs and crosstalk caused by moisture forming electrical leakage paths on terminal boards and insulating strips.
- d. Leakage paths provided by moisture between battery terminals.

#### 47. Treatment

A moistureproofing and fungiproofing treatment has been devised which, if properly applied, provides a reasonable degree of protection against

fungus growth, insects, corrosion, salt spray, and moisture. The treatment involves the use of a moisture- and fungi-resistant lacquer or varnish applied with a spray gun or brush. Refer to TB SIG 13, Moistureproofing and Fungiproofing Signal Corps Equipment, for a detailed description of the varnish- and lacquer-spray method of moistureproofing and fungiproofing.

**Caution:** Varnish or lacquer spray may have toxic effects if inhaled. To avoid inhaling spray, use respirator if available; otherwise, fasten cheesecloth or other material over nose and mouth.

#### 48. Step-by-step Instructions

a. PREPARATION. Make all repairs and adjustments necessary for proper operation of the equipment.

b. DISASSEMBLY. (1) Remove Radio Receiver and Transmitter BC-1000-A chassis from its case.

(2) Remove the tube shields, but leave the tubes in their sockets.

(3) Remove the shield cover from transformer T2.

(4) Remove crystals XTAL1 and XTAL2.

(5) Clean all dirt, dust, rust, fungus, oil, and grease from the equipment.

c. MASKING (figs. 29 and 30). With masking tape, cover:

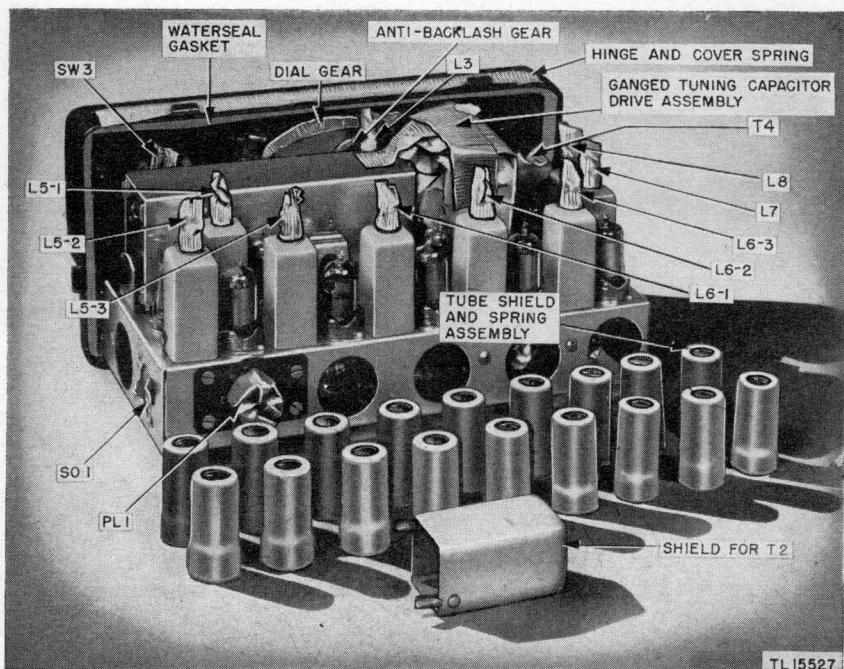

Figure 29. Radio Receiver and Transmitter BC-1000-A, masked for moistureproofing and fungiproofing—top view.

(1) The PRESS FOR DIAL LIGHT & CALIB. switch contacts (SW3).

(2) The ganged tuning capacitor gear drive assembly, including capacitor shaft coupling.

(3) The teeth on the main dial gear and the antibacklash gear.

(4) All movable tuning adjustments above the chassis.

(5) The prongs of plug PL1.

(6) The threaded studs of the shield cover for transformer T2.

(7) The back and front of metering socket SO1, or plug dummy 8-pin octal tube into socket.

(8) The crystal sockets.

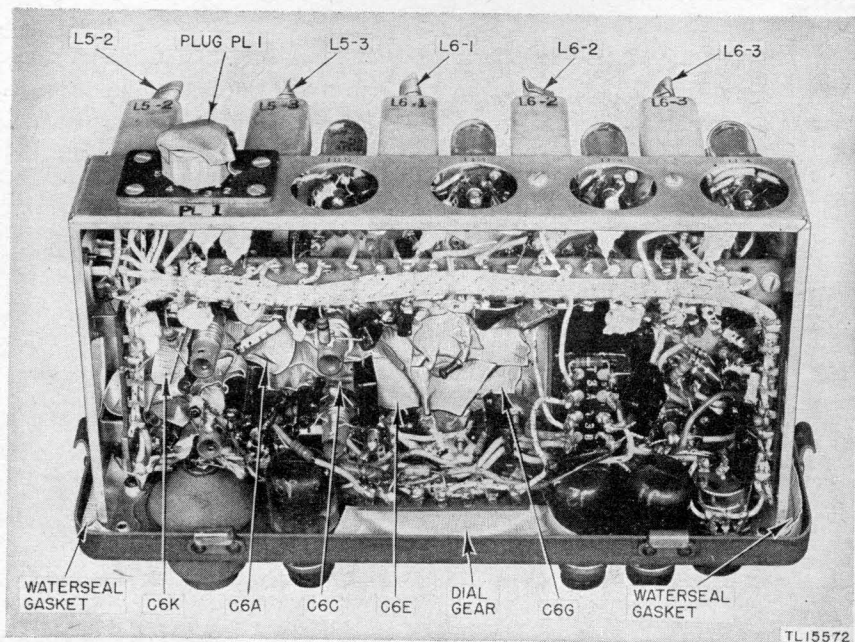

Figure 30. Radio Receiver and Transmitter BC-1000-A, masked for moistureproofing and fungiproofing—bottom view.

(9) The trimmer capacitors C6K, C6A, C6C, C6E, and C6G.

(10) All rubber gaskets and usable rubber.

(11) The hinge cover and springs.

d. DRYING. (1) Place equipment in an oven or under heat lamps and dry for 2 to 3 hours at 160° F.

(2) If the wax begins to melt at 160° F, drop the temperature to 150° F and bake for one additional hour. (Do not apply heat to batteries.)

e. VARNISHING. Apply three coats of moisture- and fungiproofing varnish (Lacquer, fungus-resistant, Spec. No. 71-2202 (Stock No.



6G1005.3), or equal) to the underside and top of the chassis, covering all components. Spray the inside and outside of the tube shields. Allow a 15- to 20-minute drying period after each coat.

f. REASSEMBLY. (1) Remove all masking tape.

(2) Touch up fixed resistors and capacitors that were covered by the masking tape.

(3) Clean all contacts with varnish and lacquer remover, and burnish the contacts.

**Caution:** Allow the set to dry for at least 12 hours before replacing it in its case. If this is not done there is danger of explosion from accumulated lacquer fumes which may be ignited by the sparks from switch contacts when the set is turned on.

(4) Reassemble the set and test its operation.

g. MARKING. Mark the letters MFP and the date of treatment near the most conspicuous or most important nameplate on the equipment and in such a location that the marking will not become obliterated or rubbed off. In the absence of a nameplate, place the marking where it can be read easily and is not subject to wear.

*Example:* MFP—8 June 1944.

*Note.* When replacing parts that are defective after the set has been moisture-proofed and fungiproofed, touch up exposed surfaces with fungus-resistant lacquer, using a brush.

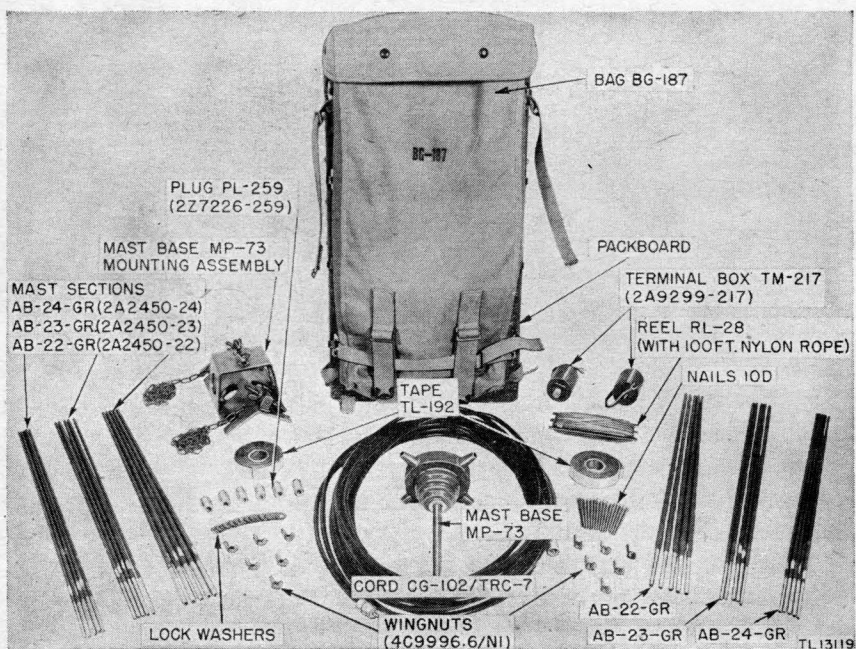

Figure 31. Antenna Equipment RC-291-( ), component parts (Numbers in parentheses are Signal Corps stock numbers).

## Chapter 4

# AUXILIARY EQUIPMENT

### Section I. ANTENNA EQUIPMENT RC-291-( )

#### 49. Description

Antenna Equipment RC-291-( ) is a ground plane antenna kit (fig. 31) especially designed for Radio Set SCR-300-A to improve its effective range in jungle areas where heavy vegetation cuts down radiation. All essential accessories are provided to simplify mounting the antenna on high trees or other elevated structures, to a maximum height of 50 feet. The theory of the antenna is discussed in paragraph 86c.

#### 50. List of Components

The following table lists the component parts of the Antenna Equipment RC-291-( ). When receiving this antenna kit, check the component parts against this list. This list is supplied as a guide and is not to be used as a basis for issue.

Table VI. List of components

Quantity	Name of component	Weight (lb.)
1	Bag BG-187.	4.31
1	Cord CG-102/TRC-7.	5.25
1	Mast Base MP-73.	7.81
10	Mast Sections AB-22/GR (5 in use, 5 spare).	1.81
10	Mast Sections AB-23/GR (5 in use, 5 spare).	0.75
10	Mast Sections AB-24/GR (5 in use, 5 spare).	0.63
1	Packboard, plywood QM No. 74-P-27-20.	4.31
1	Reel RL-28.	0.20
100 ft	Rope, nylon, 150 lb. test.	0.32
2 rolls	Tape TL-94, rubber, $\frac{3}{4}$ in. wide.	1.00
2	Terminal Box TM-217.	1.00
6	Plug PL-259 (spare).	1.00
12	Washers (spare).	0.38
12	Wingnuts (spare).	0.38
$\frac{1}{4}$ lb	Nails, 10-d., 3-in.	0.25
	Total weight.	29.40

#### 51. Mast Base MP-73

Mast Base MP-73 consists of two main parts, a V-mounting bracket and an insulator assembly with a swivel bracket. The mounting bracket has two chains that are looped around the support (tree, pole, etc.) to mount

the antenna. The swivel bracket of the insulator assembly is fastened to the V-bracket by two bolts and wingnuts. A semicircular slot is provided at the base of the insulator assembly which permits this part of the mast to be rotated about  $80^\circ$  when mounted on the V-bracket. Female inserts that will accommodate the end threads of the mast sections are located on the insulator assembly. The capacitance of the mast base is 16 micromicrofarads (mmf).

### 52. Cord CG-102/TRC-7

This cord consists of 60 feet of standard, 50-ohm, solid-dielectric, coaxial r-f cable terminated in two Plugs PL-259, one at each end.

### 53. Terminal Box TM-217

Terminal Box TM-217, a cylindrical phenolic box, 2 inches in diameter and  $2\frac{3}{8}$  inches long, incloses the antenna impedance-matching network. This network is a parallel-tuned circuit consisting of a 15-mmf capacitor and a 1.05-microhenry (uh) coil, tapped at 0.26 uh for the coaxial connector. A bolt, insulated from the housing and located at the bottom end

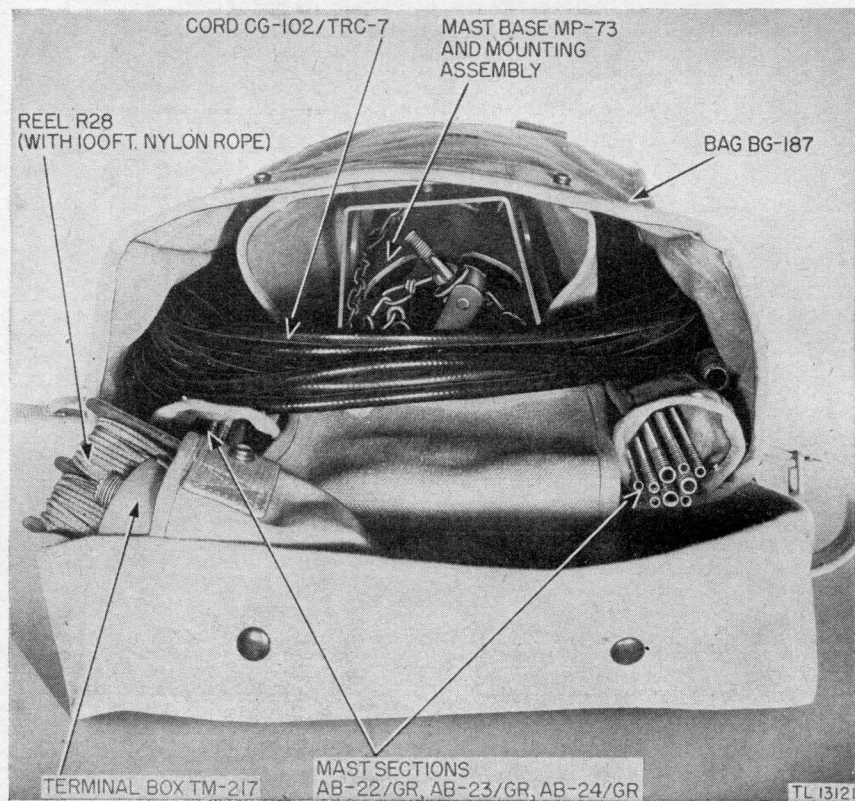

Figure 32. Bag BG-187, with components in place.

of the box, screws into the antenna terminal of Radio Receiver and Transmitter BC-1000-A, and provides both electrical connection and mechanical support. A standard coaxial fitting, located at the top end of the housing, screws into a connector at one end of the coaxial cord. A flexible ground lead, attached to the side, connects to the GROUND FOR SHORT ANT. post on the radio set.

#### 54. Mast Sections AB-24/GR, AB-23/GR, AND AB-22/GR

Fifteen mast sections are provided for the assembly of one radiator and four radials. Each radial, as well as the radiator, consists of Mast Section AB-24/GR inserted into AB-23/GR, which, in turn, is inserted into AB-22/GR. The effective length of each mast section is 20 inches.

#### 55. Bag BG-187

All the components necessary for the antenna erection are packed in this canvas bag. The mast base and mast sections fit into special compartments of the bag (fig. 32). A pocket inside the top cover is provided



Figure 33. Bag BG-187, with components mounted on QM packboard.

for rope, washers, wingnuts, nails, and tape. The bag is attached to a standard Quartermaster (QM) plywood packboard by two web straps which pass over the top of the board, come under the bottom edge, and fasten to two buckles. Two additional horizontal straps fasten in front of the bag to hold the equipment in place in the bag. Figure 33 shows the Bag BG-187 mounted on the QM packboard.

## 56. Installation

**a. LOCATION OF ANTENNA.** Select a tree at the edge of a wooded area, or else erect a pole in a clear area. The tree or pole should be 2-or more inches in diameter and should be able to support easily the weight of the equipment to be mounted on it. If a tree is used, it should be topped before installing the antenna (fig. 34).

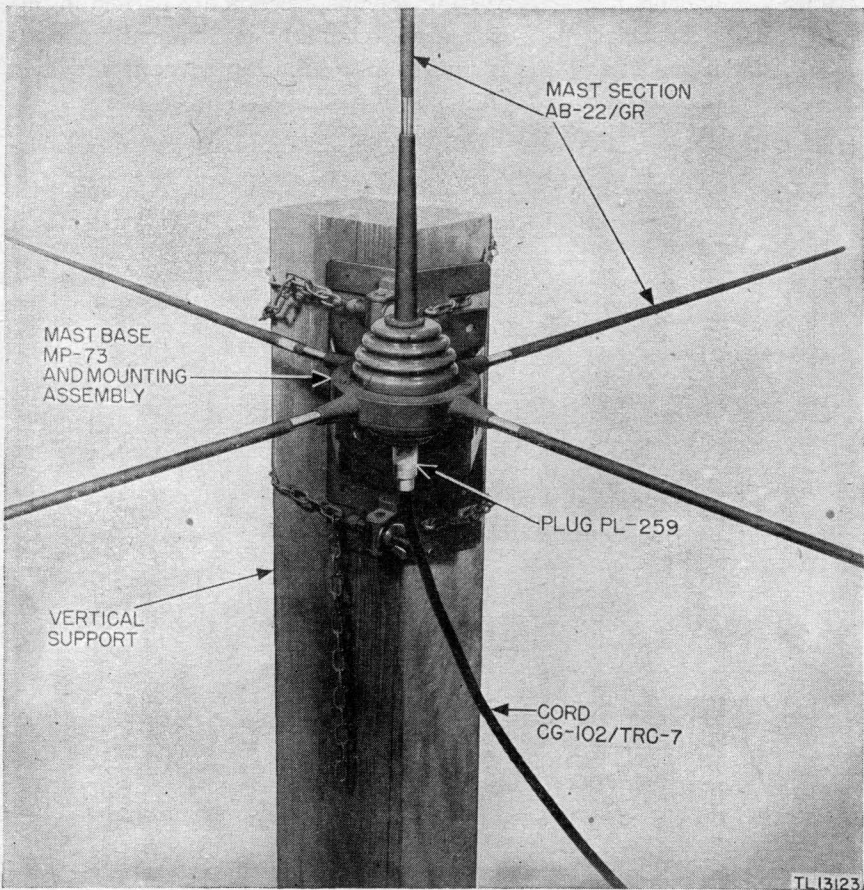

Figure 34. Antenna Equipment RC-291(-), showing Mast Base MP-73 and mounting assembly, installed on support.

b. ERECTION OF THE ANTENNA. (1) *Preparing V-bracket for mounting.* Remove the V-bracket and insulator assembly from the carrying bag. Loosen the wingnuts on the drawbolts that hold the chains until as much of each bolt is exposed as is possible without removing the nut.

(2) *Mounting V-bracket.* Haul the V-bracket to the top of the pole or tree, using the rope provided for the purpose, and loop the nearest link over the hook on the end of the drawbolt. Tighten the drawbolt

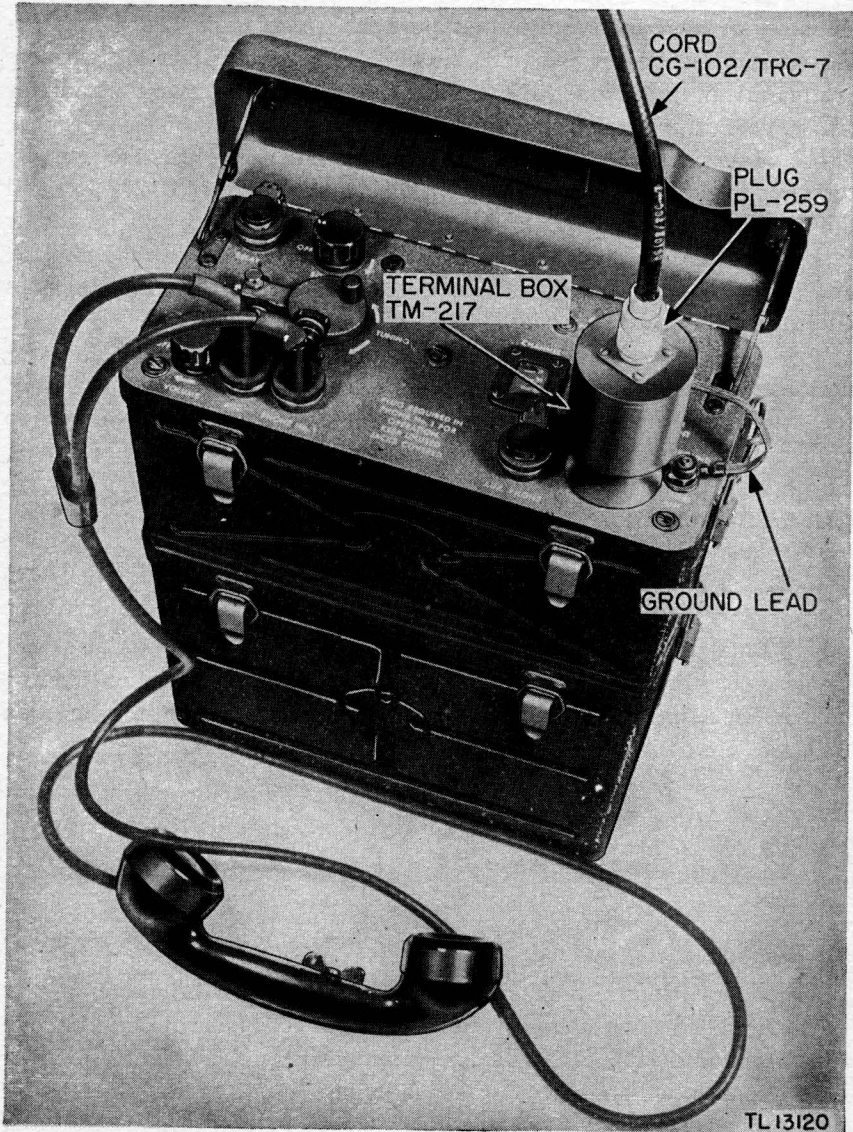

Figure 35. Fastening the coaxial cord to the terminal box attached to Radio Receiver and Transmitter BC-1000-A.

wingnut until the chain bites into the support. Repeat the procedure with the bottom chain.

(3) *Nailing V-bracket.* If convenient, nail the V-bracket to the support by hammering nails through the holes provided. If the lag bolts are available, put them through the  $\frac{3}{8}$ -inch holes provided on the V-bracket. If a tree is used, the part above the bracket must be cut off with a saw, axe, or machete.

(4) *Mounting insulator assembly to mast base.* Haul the insulator assembly of the mast base to the top of the support and fasten it to the V-bracket by using the wingnuts supplied. Be certain that lockwashers are placed under them. Adjust the swivel bracket so that the radiator will be vertical when inserted into its socket.

(5) *Assembling mast sections.* Assemble one set of mast sections by screwing Mast Section AB-24/GR into Mast Section AB-23/GR, and this into Mast Section AB-22/GR. Assemble four more sets in similar fashion. Haul the five sets of mast sections to the top of the support and screw them into the five female inserts that project from the sides and top of the mast base (fig. 34).

(6) *Fastening coaxial cord to mast base.* Pull Cord CG-102/TRC-7 up the support and fasten one end to the coaxial fitting at the bottom of the insulator assembly. Screw down tightly and cover the connection with rubber tape. Tape all other bright metal that may be exposed. Strain relief must be provided by tying the coaxial line to the supporting post with rope or tape just under the mast base.

(7) *Fastening coaxial cord to terminal box* (fig. 35). Terminal Box TM-217 is screwed into the radio set antenna insulator. The ground lead of the terminal box is connected to the GROUND FOR SHORT ANT. binding post on Radio Receiver and Transmitter BC-1000-A. Connect the other end of the coaxial cord to the coaxial fitting at the top end of the terminal box. Screw down tightly and cover the connection with rubber tape.

## Section II. MICROPHONE T-45 AND CORD CD-318

### 57. Description

Microphone T-45 is a small, single-button, carbon-type, differential microphone designed to be worn on the upper lip. It is held in place by face straps and adjustable ear loops, and is intended for use when an operator must have both hands free. The inherent design of the microphone reduces background noise, and allows speech to be reproduced clearly under all conditions. When this microphone is used with Radio Set SCR-300-A, it is used in conjunction with Cord CD-318. This cord

contains Switch SW-141 which is used in a manner similar to the receive-transmit switch in the handle of Handset TS-15-( ). Headset HS-30-( ) is used with Microphone T-45. These two units are required to replace Handset TS-15-( )

### 58. List of Components

The following table lists the component parts of Microphone T-45 and Cord CD-318. When receiving this microphone equipment, check the component parts against this list. This list is supplied as a guide and is not to be used as a basis for issue.

Table VII. List of components

Quantity	Components of Microphone T-45	Weight (lb.)
1	Microphone Unit MC-419	
3	Breath shield (1 in use 2 spare)	
1	Plug PL-291	
1	Strap ST-53, includes	
1	Face strap (left)	
1	Face strap (right)	
1	Microphone bracket	
	Total weight	.094
Quantity	Components of Cord CD-318	Weight (lb.)
1	Plug PL-68	
1	Switch SW-141	
1	Jack JK-48	
1	Cord connecting Plug PL-68 and Switch SW-141	
1	Cord connecting Switch SW-141 and Jack JK-48	
1	Neck strap	
	Total weight	.72

### 59. Microphone T-45

a. MICROPHONE UNIT MC-419. Microphone Unit MC-419 is a noise-canceling, single-button, carbon-type microphone designed for operation on a nominal current of 50 milliamperes. The resistance of the unit is between 50 and 125 ohms at 1,000 cycles per second. Frequency response is substantially flat from 200 to 4,000 cycles per second. This unit is worn close to the operator's mouth and responds to his voice. However sounds originating farther away, such as background noise or battle noise, are cancelled in the microphone because of its differential type of construction.

b. STRAP ST-53. Strap ST-53 consists of two face straps, right and left, a microphone bracket, and a cord terminating in Plug PL-291. A



6½ inch length of the cord is molded into the right-hand face strap (fig. 36).

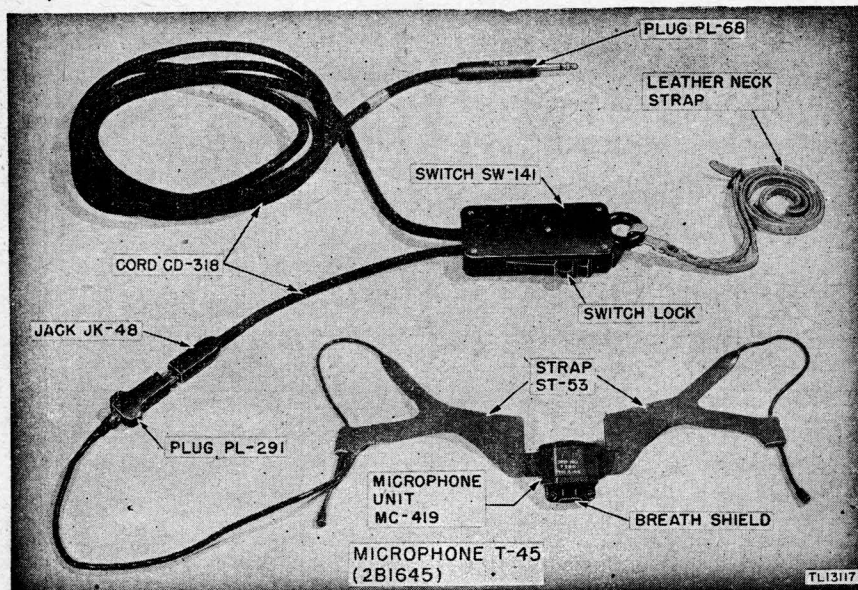

Figure 36. Microphone T-45 and Cord CD-318, component parts.

## 60. Cord CD-318

Cord CD-318, which is used with Microphone T-45, is composed of Switch SW-141, Jack JK-48, a short cord connecting the two, Plug PL-68 which is connected to Switch SW-141 by a cable, and a strap that fits around the neck of the operator and enables the entire assembly to rest on his chest.

## 61. Installation

Microphone T-45, when used with Radio Set SCR-300-A, is worn in conjunction with Headset HS-30-( ). The correct procedure for assembling and wearing Microphone T-45 and Cord CD-318 follows (fig. 37).

a. Place the assembly on the head and adjust Strap ST-53 so that Microphone Unit MC-419 rests on the upper lip.

b. Adjust the two draw strings to provide a comfortable and secure fit so that the microphone will remain in place despite movement of the head. If the draw strings do not move easily, moisten them slightly with water. Once correctly adjusted, Microphone T-45 can be removed and worn again without further adjustment.

c. Center Microphone T-45 so that the breath shield is directly under the nose. The top of Microphone Unit MC-419 should touch the nose.

Microphone T-45 is designed to work as close to the mouth as possible. If it does not remain within 3/16 inch of the mouth, bend the metal uprights of the microphone bracket inward (toward the face) until it is in the correct position.

d. Insert Plug PL-291 into Jack JK-48.

e. Insert Plug PL-68 into MIC. jack which is located on the front panel of Radio Set SCR-300-A. When Microphone T-45 is used, in conjunction with Headset HS-30-( ), Plug PL-55 of the headset must be inserted in PHONE No. 1 jack.

## 62. Operation

Switch SW-141 is used as the receive-transmit switch in the operation of Radio Set SCR-300-A and performs the same function as the receive-transmit switch on the handle of Handset TS-15-( ). The button located on the switch is pressed in order to transmit, and is released in order to receive. The switch is so constructed that the button may be pressed and locked in the transmit position.

## 63. Precautions

The following precautions are recommended when Microphone T-45 is used:

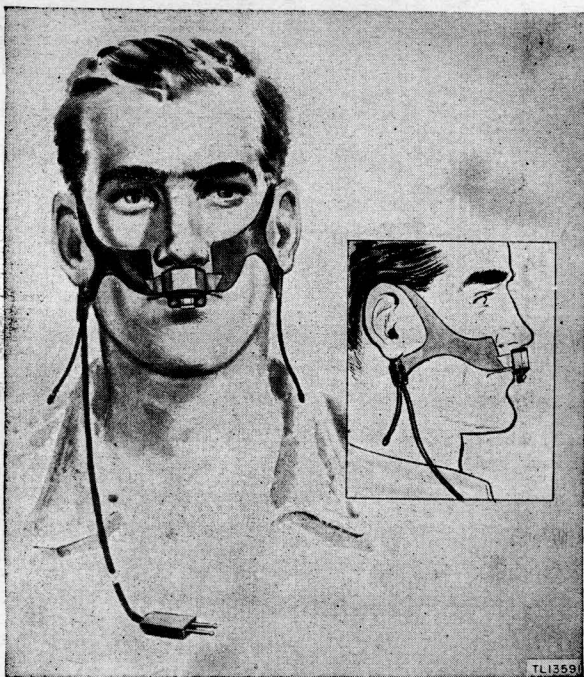

Figure 37. Microphone T-45, in use.

- a. Keep the microphone away from intense heat.
- b. Wrap the microphone in cloth when carrying or storing.
- c. Do not allow the microphone to be crushed by other equipment.
- d. Protect the microphone from dirt.

### Section III. PACKBOARD TRANSPORT

#### 64. Purpose

Discomfort, caused by pressure on certain parts of the body, has been encountered in the manpack transport of Radio Set SCR-300-A under jungle conditions when the set is carried by means of the regularly provided harness. To relieve this discomfort, methods have been devised for carrying the set attached to a QM packboard.

#### 65. Procurement

Packboards are available within the Infantry Division. Three separate items of quartermaster equipment comprise the complete packboard assembly for carrying the radio set:

<i>Item</i>	<i>QM stock No.</i>	<i>Name and description</i>
1 .....	74-P-27-20 .....	Packboard, plywood.
2 (optional) .....	74-S-349-80 .....	Strap, quick release, packboard, type 1.
3 (optional) .....	74-A-33-30 .....	Attachment, packboard, plywood, cargo, pressed steel.

The quick release straps and cargo attachment are not issued as part of the packboard, but have a separate basis of issue, because there are several specialized types of carrying attachment available for use with the packboard in addition to the regular cargo attachments. Item 3 above is the attachment designed for general cargo carrying purposes. The set may be fastened to the packboard by means of the regular packboard cargo attachments which are issued for use with the packboard, or with a suitable length of rope, if the packboard accessories are not available.

#### 66. Weights

Use of the packboard involves a small increase in the total carrying weight of the set. The weight of the set with the normal carrying harness is 38.23 pounds; weight of the set with the packboard is 40.50 pounds. This increase in weight is negligible, however, compared to the comfort and ease of transport afforded by the packboard, which distributes the weight of the set over the entire area of the back.

### 67. Use

Two variations in the assembly of the set to the packboards are provided:

a. Assembly of the complete radio set, including Case CS-128-( )\* with light battery BA-80 or heavy Battery BA-70, to the packboard for use in amphibious operations.

b. Assembly of the radio set to the packboard using light battery BA-80 *without* Case CS-128-( ), to achieve a maximum reduction in carrying weight when amphibious operations are not contemplated. Total weight for this method is 30.50 pounds.

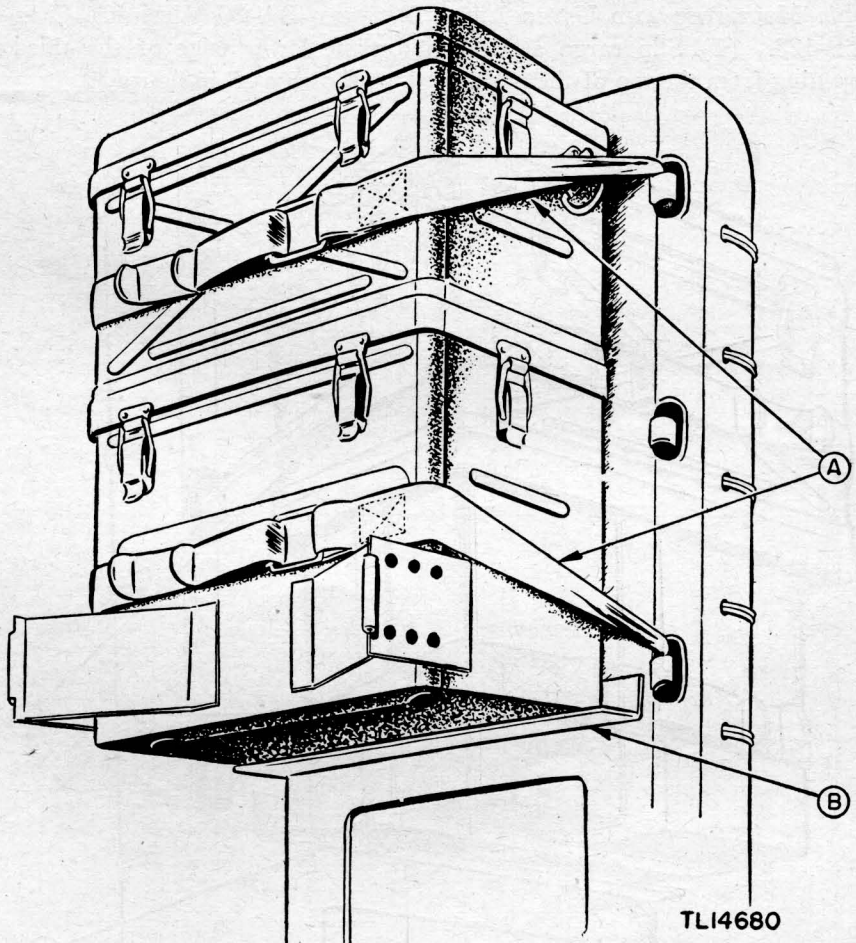

Figure 38. Complete Radio Set SCR-300-A, mounted to standard QM packboard, using quick release straps and cargo attachment.

\*Case CS-128-( ) is reversed when attached to radio receiver and transmitter BC-1000-A, when set is to be secured to packboard.

### 68. Mounting Set on Packboard

Recommended methods of attaching Radio Set SCR-300-A to a QM packboard follow.

*a. COMPLETE MOUNTING.* (1) Slip the cargo attachment on the lower edge of the third opening from the top of the packboard as shown at *B* in figure 38.

(2) Mount the complete radio set to the packboard and fasten securely with two quick release straps, as shown at *A* in figure 38.

(3) If the cargo attachment and quick release straps are not available, fasten the set to the packboard using rope, as shown in figure 40.

*b. MOUNTING AND USING LIGHT BATTERY BA-80 WITHOUT CASE CS-128.* (1) Slip cargo attachment on the lower edge of the third opening from the top of the packboard, as shown at *B* in figure 39.

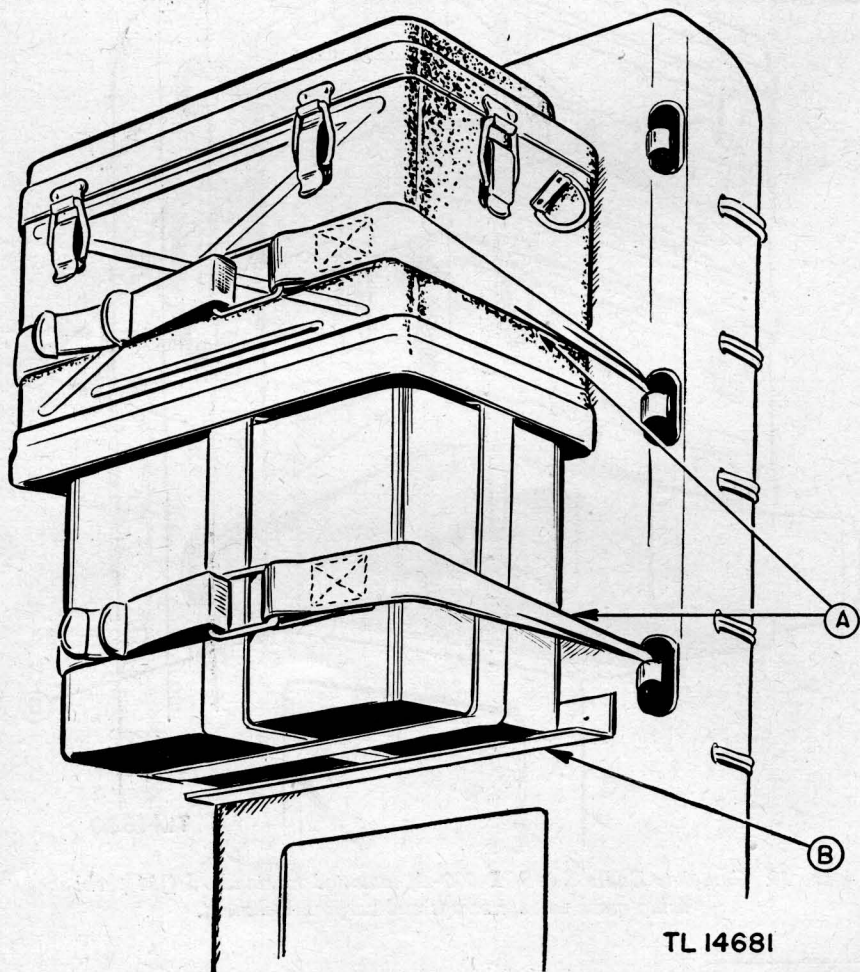
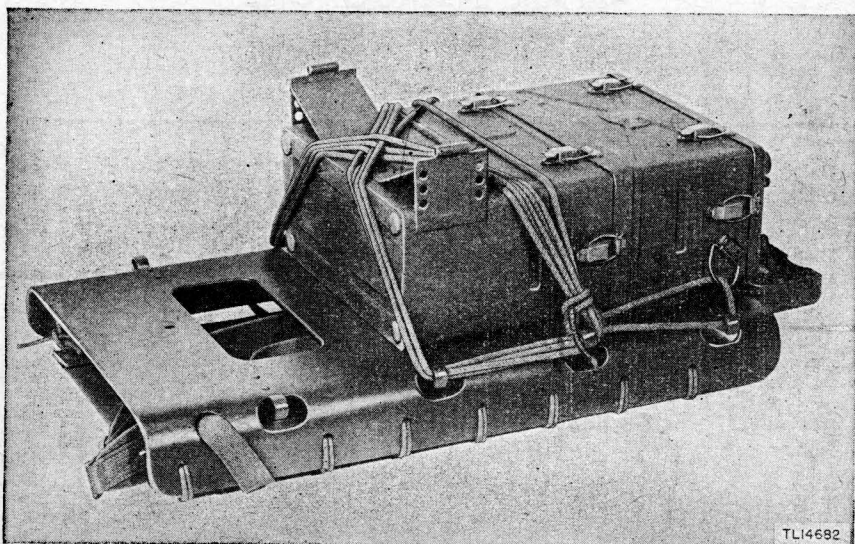

Figure 39. Radio Set SCR-300-A, with Battery BA-80 mounted to standard QM packboard, using quick release straps and cargo attachment.

(2) Mount the radio set with Battery BA-80 to the packboard and fasten securely with the quick release straps as shown at *A* in figure 39.

(3) If the cargo attachment and quick release straps are not available, fasten the set to the packboard using rope as shown in figure 41.



*Figure 40. Radio Set SCR-300-A, showing method of fastening to standard QM packboard using rope.*

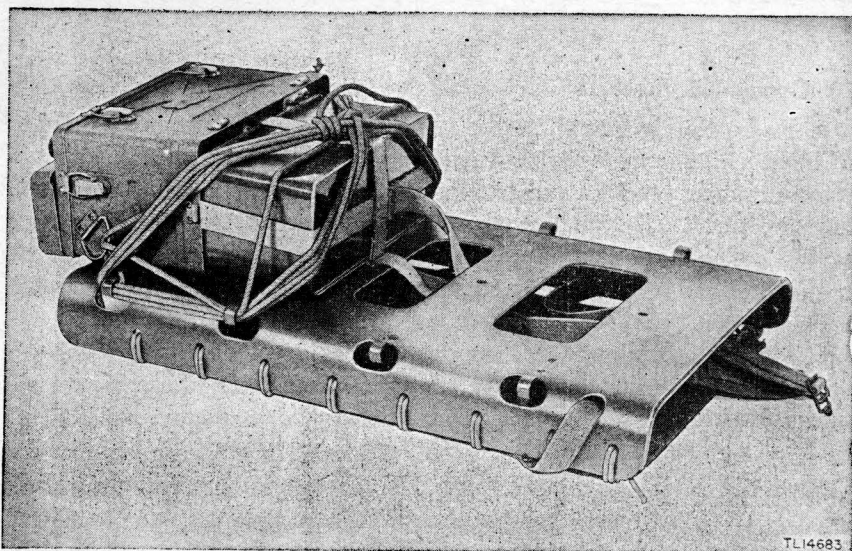

*Figure 41. Radio Set SCR-300-A, with Battery BA-80, showing method of fastening to standard QM packboard using rope.*

## Chapter 5

# REPAIR INSTRUCTIONS

---

*Note.* Failure or unsatisfactory performance of equipment used by Army Ground Forces and Army Service Forces will be reported on WD AGO Form 468, (Unsatisfactory Equipment Report). For particulars see paragraph 115. If Form 468 is not available, see TM 38-250. Failure or unsatisfactory performance of equipment used by Army Air Forces will be reported on Army Air Forces Form 54, Unsatisfactory Report.

### Section I. THEORY OF EQUIPMENT

#### 69. Treatment of Theory

The functional theory of Radio Receiver and Transmitter BC-1000-A will be treated in two ways. The first will be a condensed circuit analysis which is keyed to a block diagram and will show signal paths. It can be used for introductory or quick review purposes. The second presents a detailed analysis of each functional circuit used in Radio Receiver and Transmitter BC-1000-A.

#### 70. Condensed Theory of Operation

*a.* Radio Receiver and Transmitter BC-1000-A consists of a number of interlocking circuits which provide rapid change-over from receive to transmit. The receiver and transmitter frequency is varied by a single tuning control. This makes it possible to change operating frequencies rapidly. The block diagram (fig. 42) shows the signal paths through the transmitter and receiver. The same antenna is used for both transmission and reception.

*b.* During reception, the incoming signal is passed through the r-f amplifier tube V6, to the grid of the first mixer tube V7 of the double superheterodyne (a superheterodyne which has two intermediate frequency (i-f) channels). The master oscillator tube V4, and doubler tube V3, produce a local oscillator frequency, which is mixed with an incoming signal frequency in the receiver first mixer to produce a 4.3-mc *difference* frequency for the first i-f amplifier system. This same oscillator and doubler also operate during transmission. During transmission, the output of the doubler is fed to the transmitter mixer tube V2 and is

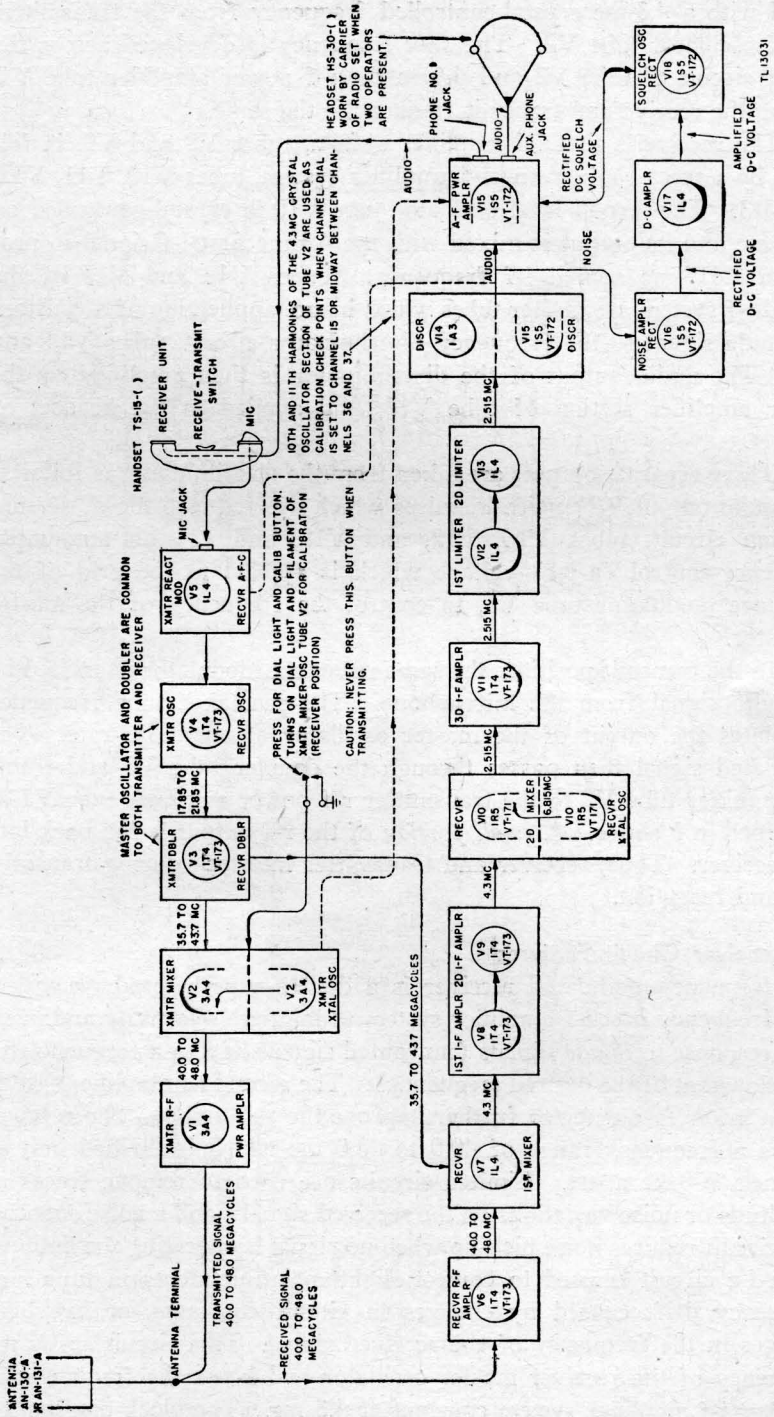

Figure 42. Radio Receiver and Transmitter BC-1000-A—block diagram.



mixed with a 4.3-mc crystal-controlled frequency from the transmitter crystal-oscillator tube V2. The *sum* frequency is developed across the output circuit of tube V2 and drives the r-f power amplifier tube V1, making the receive and transmit frequencies the same.

c. The receiver's first i-f amplifier system, tubes V8 and V9, is followed by a second mixer and i-f amplifier system, tubes V10, V11, V12, and V13. The second local oscillator tube V10 is crystal-controlled on 6.815 mc and its output is mixed with the 4.3-mc first i-f signal to produce a 2.515-mc second i-f frequency. Tubes V12 and V13 of the second i-f system are limiter tubes which insure application of a constant amplitude signal to the frequency discriminator circuit, tubes V14 and V15. The audio output of the discriminator is then amplified by the power amplifier section of tube V15, and applied to the headset or handset.

d. Three separate outputs are taken from the discriminator as follows: (1) audio output, (2) noise impulses which are fed into the noise suppression circuit, tubes V16, V17, and V18, and (3) an automatic-frequency-control (a-f-c) voltage which is applied to the grid of the reactance modulator tube V5, to control the frequency of the master oscillator.

e. In the transmit position, the same reactance modulator is excited by an audio signal from the microphone. The reactance tube frequency modulates the output of the master oscillator at an audio rate. The modulated signal then passes through the doubler tube V3 and transmitter mixer tube V2 to the transmitter r-f power amplifier tube V1 as explained in *b* above. A *small portion* of the r-f output is fed back into the receiver. Thus, receiver and transmitter interlock during transmission and reception.

## 71. Receiver Circuit Features

The frequency-modulated receiver is a double superheterodyne with a high-frequency first i-f amplifier system to improve selectivity and minimize response to *image* signals (unwanted signals having a frequency 8.6 mc below that of the desired frequency). The second i-f amplifier system uses a lower frequency to further improve the selectivity. The receiver covers a frequency range of 40.0 to 48.0 mc which is divided into 41 channels 200 kc apart. Limiter circuits are used to remove traces of amplitude or noise variations on the received signals, and a noise suppression circuit reduces noise pick-up when no signal is operating the limiters. An a-f-c circuit is used to correct slight maladjustments in tuning or frequency drift caused by changes in circuit constants, or by slight changes in the frequency of the received signal. This circuit shifts the frequency of the receiver master oscillator and keeps the frequency of the first i-f amplifier system constant at 4.3 mc. The block diagram of the receiver is shown in figure 43.

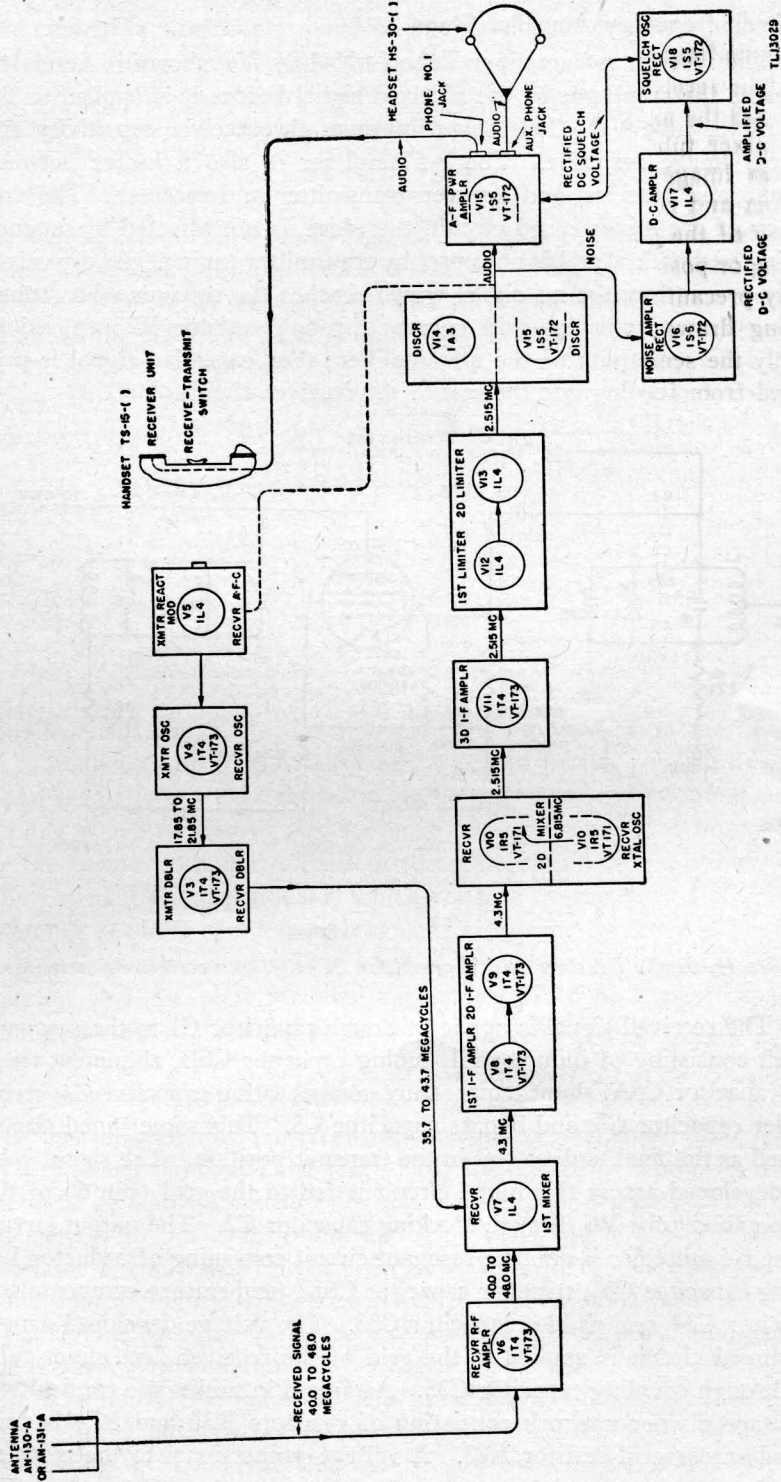
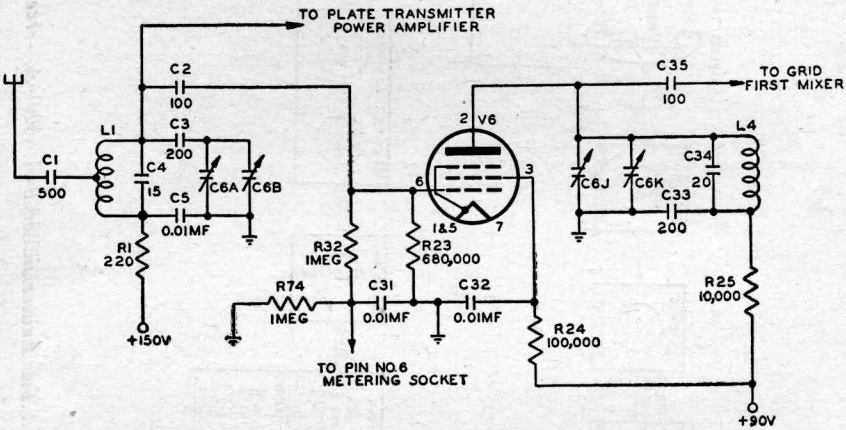

Figure 43. Radio Receiver and Transmitter BC-1000-A, receiver-block diagram.

## 72. Radio-frequency Amplifier Stage

a. The receiver r-f amplifier Tube JAN-1T4, V6, shown in figure 44, increases the amplitude of the received signal before it is applied to the first mixer tube V7. This stage improves the receiver sensitivity and reduces image response. The r-f amplifier is also a buffer between antenna and receiver, and between transmitter and receiver. The frequency of the mixer tuned circuit, therefore, is not affected by antenna loading or position, and is not upset by transmitter tuning. As a receiver safety precaution, the r-f signal which reaches the receiver when transmitting draws sufficient grid current through resistor R23 to reduce greatly the sensitivity of the r-f amplifier; thus excessive signal is prevented from feeding into the rest of the receiver circuit.



TL 14518

Figure 44. Radio Receiver and Transmitter BC-1000-A, receiver r-f amplifier.

b. The received signal is applied through capacitor C1 to the resonant circuit consisting of inductor L1, tuning capacitor C6B, alignment trimmer capacitor C6A, shunt temperature compensating capacitor C4, series padder capacitor C3, and bypass capacitor C5. This same tuned circuit is used as the final tank circuit in the transmit position. The signal voltage developed across this tuned circuit is fed to the grid (pin 6) of the r-f amplifier tube V6 through blocking capacitor C2. The output circuit of the r-f amplifier is another resonant circuit consisting of inductor L4, tuning capacitor C6J, trimmer capacitor C6K, temperature compensating capacitor C34, and padder capacitor C33. The voltage developed across this tuned circuit is applied to the grid of the receiver first mixer tube V7 through coupling capacitor C35. As an aid in tuning the transmitter, a voltage divider network consisting of resistors R32 and R74 is connected across grid resistor R23. A voltage proportional to the rectified

grid current is measured at pin No. 6 of the metering socket. Capacitor C31 keeps radio frequency out of the metering circuit. Resistor R24 is the screen voltage-dropping resistor, C32 the screen bypass capacitor, and R25 the plate decoupling resistor.

### 73. First Mixer Stage

First mixer stage Tube JAN-1L4, V7, is triode connected as shown in figure 45. This stage converts the received signal to a 4.3-mc i-f frequency. The signal voltage developed across the single tuned resonant circuit in the preceding stage is applied to the grid of the mixer through

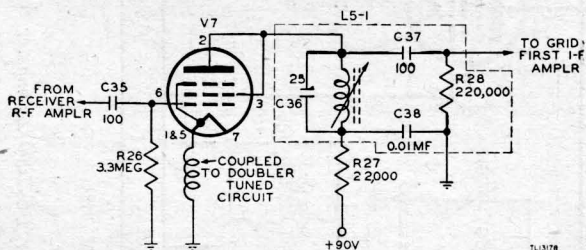

Figure 45. Radio Receiver and Transmitter BC-1000-A, receiver first mixer.

coupling capacitor C35. Local oscillations are applied to the filament by a small pick-up loop coupled to the output of the doubler tube V3. Local oscillations are 4.3 mc below the frequency of the incoming signal. Mixing occurs in tube V7. A 4.3-mc *difference* frequency is brought out by the parallel resonant circuit in the plate circuit of the mixer tube. The resonant circuit of L5-1, which consists of capacitor C36 and an inductor, is tuned to the exact resonant frequency by the variable iron-core tuning adjustment. This stage also contains the following items: coupling and d-c plate blocking capacitor C37, plate bypass capacitor C38, grid resistor R28, and plate decoupling resistor R27.

### 74. Master Oscillator and Doubler

a. Master-oscillator (receiver and transmitter oscillator) Tube JAN-1T4, V4, and doubler Tube JAN-1T4, V3, shown in figure 46, supply the local oscillator frequency for the receiver first mixer, and the input frequency for the transmitter mixer. The frequency of the master oscillator is controlled by reactance tube V5. In the transmit position, the frequency of the master oscillator is controlled by the audio signal from the microphone; in the receive position, by the a-f-c voltage from the receiver discriminator.

b. The master oscillator V4 is a tuned-plate, untuned-grid oscillator. Class C grid bias (two or three times cut-off) is developed by the flow of rectified grid current through resistor R14. The grid resistor is

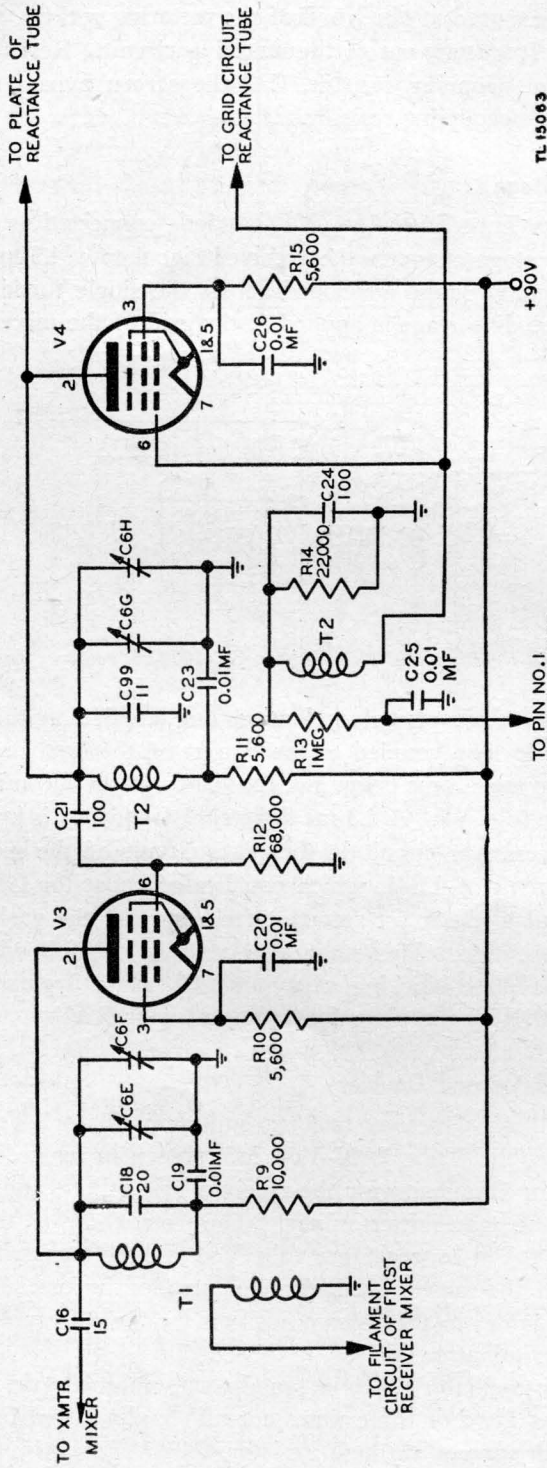

TL 15093

TO PIN NO. 1  
METERING SOCKET

Figure 46. Radio Receiver and Transmitter BC-1000-A, master oscillator and doubler.

bypassed for r-f variations by capacitor C24. The relative value of bias developed across the grid resistor can be measured at pin No. 1 of the metering socket. The metering lead filter system consists of series resistor R13 and shunt capacitor C25. The tuned plate circuit consists of inductor T2, tuning capacitor C6H, trimmer capacitor C6G, temperature compensating capacitor C99, and plate bypass capacitor C23. At the resonant frequency, a portion of the signal developed across the tuned plate circuit is coupled magnetically to the grid coil, and is of the proper phase and amplitude to sustain oscillations. The oscillations cover a frequency range of 17.85 to 21.85 mc, tunable with capacitor C6H. To start the oscillator, no external or cathode bias is used (zero biasing is necessary to start oscillations; rectified grid current drives grid to Class C point after oscillations start) because the filament of V4 is returned directly to ground. R15 is the screen voltage-dropping resistor, C26 is the screen bypass capacitor, C21 the coupling and d-c plate blocking capacitor to the grid of doubler tube V3, and R11 the plate decoupling resistor.

c. The oscillator output is capacitively coupled to the grid of the doubler V3. The doubler plate circuit which covers a frequency range of 35.7 to 43.7 mc is resonant at the second harmonic of the grid signal, and can be tuned with capacitor C6F. To insure efficient doubler operation, the tube is operated with high screen potential and a high-value grid resistor. The tube is driven beyond the normal Class C biasing point by high grid excitation and produces an output wave form which has a large second harmonic content. Two outputs are taken from the doubler stage; the first, by means of a pick-up coil circuit which injects signal into the filament of the receiver mixer V7; the second, through coupling capacitor C16 to the grid of the transmitter mixer V2. Other parts in the circuit are screen voltage-dropping resistor R10, screen bypass capacitor C20, plate decoupling resistor R9, shunt capacitor C18, plate bypass capacitor C19, plate tuning and coupling coils T1, coupling capacitor C16, trimmer capacitor C6E, and grid resistor R12.

### 75. First Intermediate-frequency Amplifier System

The first i-f amplifier system consisting of two Tubes JAN-1T4, V8 and V9, as shown in figure 47, amplifies the 4.3-mc output of the first mixer V7 before application to the second mixer of the receiver. The i-f coupling transformer L5-2 between the first and second i-f amplifiers consists of a single tuned circuit formed by capacitor C40 and a tunable iron-core inductor, coupling capacitor C41, plate bypass capacitor C42, and grid resistor R31, all inclosed by a shield. The i-f transformer L5-3 between the second i-f amplifier tube and the second mixer is the same as L5-2, containing tuning capacitor C44, tunable iron-core inductor, coupling capacitor C45, plate bypass capacitor C46, and grid resistor R34. The

use of the tunable iron-core inductor insures frequency stability and high gain as it is more rigid mechanically and minimizes the capacitance of the parts to ground. Other parts in the circuits are: plate decoupling resistors R30 and R33, coupling and d-c plate blocking capacitor C37, screen voltage-dropping resistor R29, screen bypass capacitor C39, and grid resistor R28.

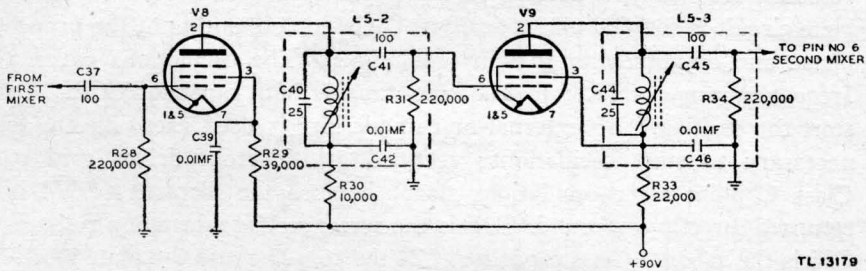

TL 13179

Figure 47. Radio Receiver and Transmitter BC-1000-A, receiver first i-f amplifier system.

## 76. Second Mixer and Crystal Oscillator

a. The second mixer and crystal-oscillator Tube JAN-1R5, V10, as shown in figure 48, mixes the 4.3-mc first i-f signal with the crystal-controlled frequency to produce a new intermediate-frequency of 2.515 mc. The oscillator section of the converter, on a frequency of 6.815 mc, is a Pierce oscillator with the anode grid of the converter serving as the plate of a triode oscillator. The 4.3-mc signal is applied to the third grid of the converter. The oscillator signal is mixed with the first i-f signal in the electron stream of the tube. The difference frequency is brought out in the parallel resonant plate circuit tuned to 2.515 mc. The interstage transformer L6-1 contains tuning capacitor C49, tunable iron

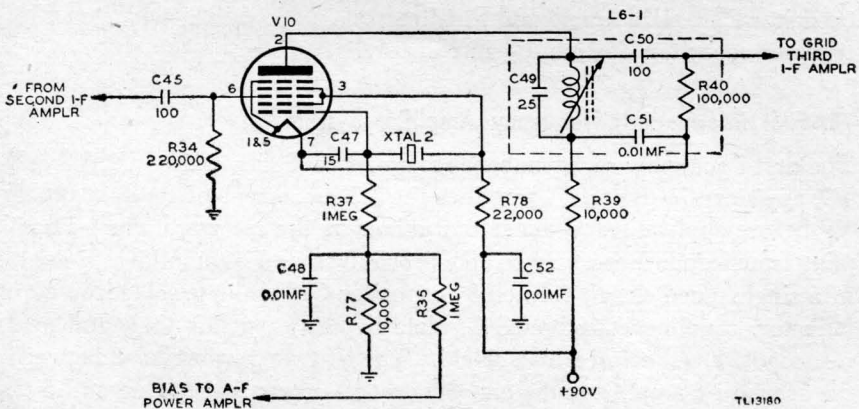

TL13180

Figure 48. Radio Receiver and Transmitter BC-1000-A, receiver second mixer and crystal oscillator.

inductor, coupling capacitor C50, plate bypass capacitor C51, and grid resistor R40. The circuit also contains decoupling resistor R39, grid resistors R34, R77, and R37, coupling capacitor C45, a-f power amplifier bias filtering circuit capacitor C48 and resistor R35, crystal XTAL 2, and decoupling capacitor C52. Capacitor C47 adds to the interelectrode capacity existing between oscillator grid and filament.

b. A Pierce crystal-controlled oscillator circuit generates the local oscillations. A quartz crystal connected directly between the control grid and anode grid (plate of the triode oscillator section) of the tube serves as a tuned circuit of high  $Q$ , replacing the conventional coil and tuning capacitor. The divider of crystal voltage consists of the capacitance between the anode grid and cathode, and the parallel combination of C47 and the interelectrode capacitance between control grid and cathode. The anode potential is applied through decoupling resistor R78. Rectified grid current flows through resistors R37 and R77, and sets the Class C oscillator bias. Voltage developed across resistor R77 is applied through isolating resistors R35, R70, and R71 as bias to the audio-frequency (a-f) power amplifier, V15.

## 77. Second Intermediate-frequency Amplifier System

a. The second i-f amplifier system as shown in figure 49 consists of the third i-f amplifier Tube JAN-1T4, V11; first limiter Tube JAN-1L4, V12; and second limiter Tube JAN-1L4, V13. The output of the second mixer is increased in amplitude by the third i-f amplifier before application to the limiter stages. The limiter stages confine the i-f signal within fixed voltage limits regardless of the strength of the incoming signal. (This does not apply to a very *weak* signal which may not have sufficient amplitude to swing between these levels.) The signal applied to the frequency discriminator is, therefore, constant in amplitude. The audio output of the receiver is reasonably constant in volume and free of interference from weaker signals on the same frequency.

b. The coupling units between stages consist of single-tuned transformers L6-2 and L6-3, which are similar to the type discussed in paragraph 69 except that they are tuned to the lower frequency of the second i-f amplifier system. L6-2 contains tuning capacitor C53, tunable iron-core inductor, coupling capacitor C54, plate bypass capacitor C55, and grid resistor R42. L6-3 contains tuning capacitor C57, tunable iron-core inductor, coupling capacitor C58, plate bypass capacitor C59, and grid resistor R45. L7 contains tuning capacitor C62, tunable iron-core inductor, coupling capacitor C63, and plate bypass capacitor C64. The first and second limiter tubes have sharp cut-off characteristics and are operated at low plate and screen potentials, so that all signals are confined within the narrowed operating region between cut-off and saturation. The application of a signal of reasonable amplitude to the first limiter and



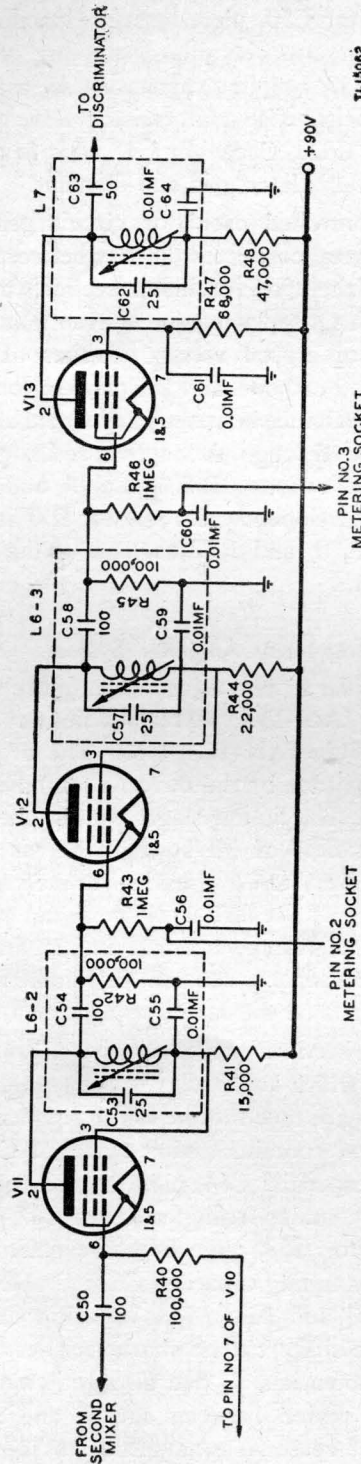

TL15062

Figure 49. Radio Receiver and Transmitter BC-1000-A, receiver second i-f amplifier system.

the effective limiting of plate current by the flow of rectified grid current through resistors R42 and R45, result in removal of all amplitude variations. The two limiter stages permit the application of a larger limited signal to the discriminator and limiting action on weak signals. Signals not strong enough to operate the first limiter fully will operate the second limiter, thus amplitude noises will be reduced even on weak signals. The output from the tuned circuit of the second limiter V13 is coupled through capacitor C63 to the midpoint of capacitors C5 and C66, a part of the discriminator tuned circuit. To aid in aligning and checking the operation of the limiters, the relative value of the voltage developed across the grid resistors by rectified grid current flow can be measured at the metering socket. The first limiter voltage is applied through the isolating filter circuit which consists of resistor R43 and capacitor C56 to pin No. 2 of the metering socket; the second limiter voltage through the isolating filter circuit which consists of resistor R46 and capacitor C60 to pin No. 3 of the metering socket. The circuit also contains plate decoupling resistors R41 and R44; screen resistor R47; screen bypass capacitor C61; coupling capacitor C50; and grid resistor R40.

## 78. Discriminator

*a.* The discriminator stage, shown in figure 50, consisting of Tube JAN-1A3, V14, and the diode section of Tube JAN-1S5, V15, converts the frequency variations of the signal into audio variations. A frequency-modulated signal of constant amplitude is presented to the discriminator circuit from the second limiter.

Discriminator action changes the frequency variations to amplitude variations which are proportional to the change in frequency of the incoming signal. (A signal which shifts  $\pm 50$  kc on each side of the resting frequency produces a greater amplitude audio signal than one shifting only  $\pm 20$  kc on each side of the resting frequency.) In addition to the audio output, two other outputs are taken from the discriminator; one operates the noise circuit and the other the a-f-c circuit.

*b.* Capacitive coupling only is used between coupling unit L7, the output circuit of the second limiter tube V13, and coupling unit L8, the tuned circuit of the discriminator. Both are resonant at 2.515 mc, the frequency of the second i-f amplifier system. The signal present across the resonant circuit in coupling unit L7 is fed to the discriminator tuned circuit from the plate side of the inductor through capacitor C63. Capacitor C69, although it introduces some unbalance, is necessary to obtain proper coupling between circuits. A portion of the r-f energy divides between capacitors C66 and C69. The voltage across capacitor C66 excites the tuned circuit in coupling unit L8. This coupling unit is composed of capacitors C65 and C66 and a tunable iron-core inductor.

*c.* At the second intermediate frequency of 2.515 mc, the phase rela-

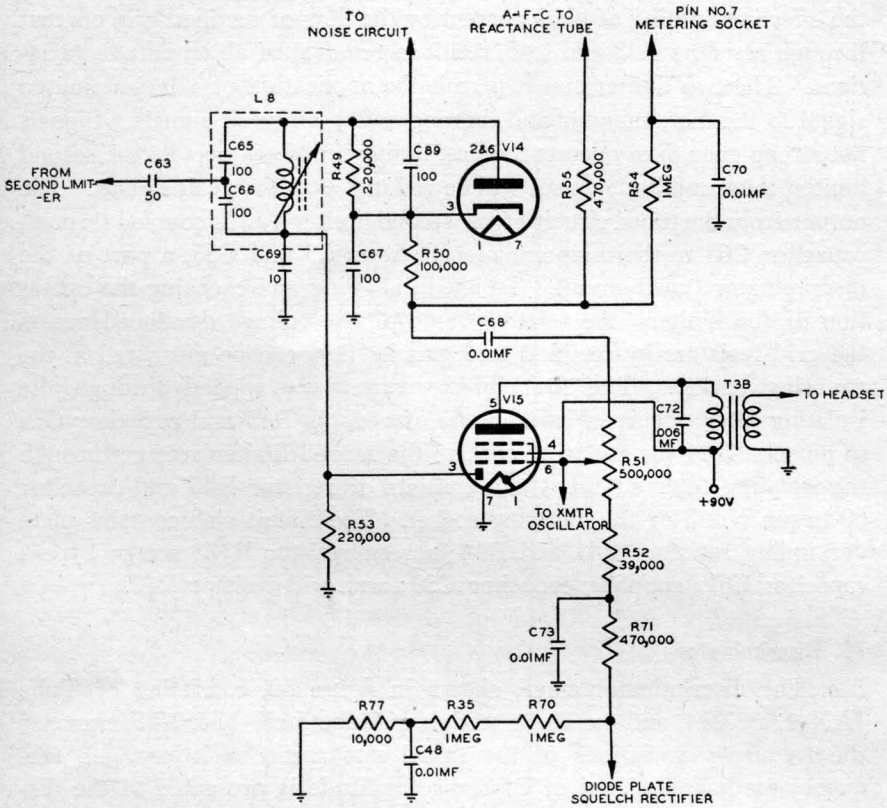

TL15064

Figure 50. Radio Receiver and Transmitter BC-1000-A, discriminator and a-f power amplifier.

tionship between the voltage developed in coupling unit L7 and the voltage developed across capacitors C65 and C66 will produce essentially equal and opposite d-c voltages across the two diode load resistors R49 and R53. The net d-c voltage is then zero between the cathode of tube V14 and ground.

d. When a frequency higher than the intermediate frequency of 2.515 mc is applied to the circuit, the phase relationship between the voltage developed in coupling unit L7 and the voltages developed across capacitors C65 and C66 shifts. This shift causes unequal voltages to be applied to the two diodes and their load resistors. This results in a positive value of d-c voltage between the cathode of tube V14 and ground. At a frequency lower than 2.515 mc, the opposite condition takes place and a negative voltage is developed between the cathode of tube V14 and ground. The frequency variations in received signals above and below the resting frequency are at an audio rate, and it is the audio voltage developed between the cathode of V14 and ground that is applied

as signal voltage to the control grid of the a-f amplifier section of tube V15. Capacitor C67 is an r-f bypass capacitor across the output of the circuit. Other components of the discriminator circuit are filter resistor R50, a-f-c filter resistor R55, metering lead filter resistor R54 and capacitor C70, and noise coupling capacitor C89.

### 79. Audio-frequency Amplifier

The audio-frequency amplifier stage consists of the pentode section of Tube JAN-1S5, V15 (fig. 50). The audio output of the discriminator is coupled through capacitor C68 to potentiometer R51, the rotor of which connects to the grid (pin No. 6) of the a-f power amplifier. The grid return for the a-f power amplifier is completed through resistors R51, R52, R71, R70, R35, and R77. Resistor R77 is also in the grid return circuit of the receiver crystal-oscillator tube V10, and the voltage developed by the flow of oscillator grid current is applied as bias to the a-f power amplifier. When the squelch circuit is operating, resistors R70, R35, and R77 are the load for the squelch circuit diode. The flow of diode current biases the a-f power amplifier (V15) beyond cut-off when the squelch circuit is operated by noise impulses. The audio output of the a-f power amplifier is transformer coupled by T3B to the headset or handset. Other components of the a-f power amplifier circuit are output transformer shunt capacitor C72 and filter capacitors C73 and C48.

### 80. Automatic-frequency Control (figs. 50 and 53)

a. An a-f-c circuit holds the center frequency of the frequency-modulated signal constant. To insure linear detection and maximum signal output, the center frequency must be held to exactly 2.515 mc at the discriminator. Frequency control is accomplished by shifting the frequency of the master oscillator V4 with the reactance modulator V5 to compensate for any shift in center frequency caused by a slight change in master-oscillator frequency, change of circuit characteristics, or frequency of the incoming signal. The grid return to ground for the reactance modulator tube V5 is completed through isolating resistors R18, R55, R50, and the diode load resistors R49 and R53. When the center frequency is 2.515 mc, the voltages across the resistors cancel and no extra bias is placed on the reactance tube. However, if the frequency shifts, the voltage across the resistor combination will become negative or positive, depending upon the direction of frequency deviation, and an additional direct current (d-c) bias will be placed on the grid of the reactance tube V5. A filter circuit, consisting of capacitor C30 and isolating resistors R18 and R55, removes the audio components from the a-f-c voltage.

b. The change in reactance tube bias adds to or subtracts from the

effective capacitance presented to the master-oscillator tuned circuit. This change in capacitance shifts the frequency of the master oscillator in the direction necessary to maintain at exactly 4.3 mc the center frequency of the signal passing through the first i-f amplifier system. Since the local oscillator for the second i-f amplifier system is crystal-controlled at 6.815 mc, it generates a stable reference frequency for the entire a-f-c circuit and will hold the center frequency of the first i-f amplifier system at 4.3 mc as well as the center frequency of the second i-f amplifier system and discriminator at exactly 2.515 mc. Frequency compensation is effected over a range of 50 kc on each side of the received frequency. Table VIII gives the frequency changes and resulting polarity of the discriminator output voltage for various conditions of frequency shift.

Table VIII. Discriminator polarities

Condition	Received signal frequency (mc)	Master-oscillator frequency (mc)	Doubler frequency (mc)	1st i-f frequency (mc)	2d i-f frequency (mc)	Discriminator polarity
Frequencies in receiver under normal conditions.	40.00	17.85	35.70	4.3	2.515	zero
Received signal higher in frequency.	40.050	17.85	35.70	4.35	2.465	negative
Received signal lower in frequency.	39.950	17.85	35.70	4.25	2.565	positive
Increase in master-oscillator frequency caused by mistuning or drift.	40.00	17.875	35.75	4.25	2.565	positive
Decrease in master-oscillator frequency caused by mistuning or drift.	40.00	17.825	35.65	4.35	2.465	negative

Another output is taken from the discriminator through capacitor C89 and applied to the noise squelch circuit. To prevent operation of the noise circuits by an audio signal, the coupling circuit permits the transfer of the high-frequency noise impulses only.

### 81. Noise Squelch Circuit

a. The noise squelch circuit as shown in figure 51 consists of a noise amplifier-rectifier Tube JAN-1S5, V16; d-c amplifier Tube JAN-1L4, V17; and squelch oscillator-rectifier Tube JAN-1S5, V18. In the reception of a frequency-modulated signal, the action of the receiver limiter prevents amplitude noise impulses from appearing in the discriminator output. However, during the intervals when no signal is received, the

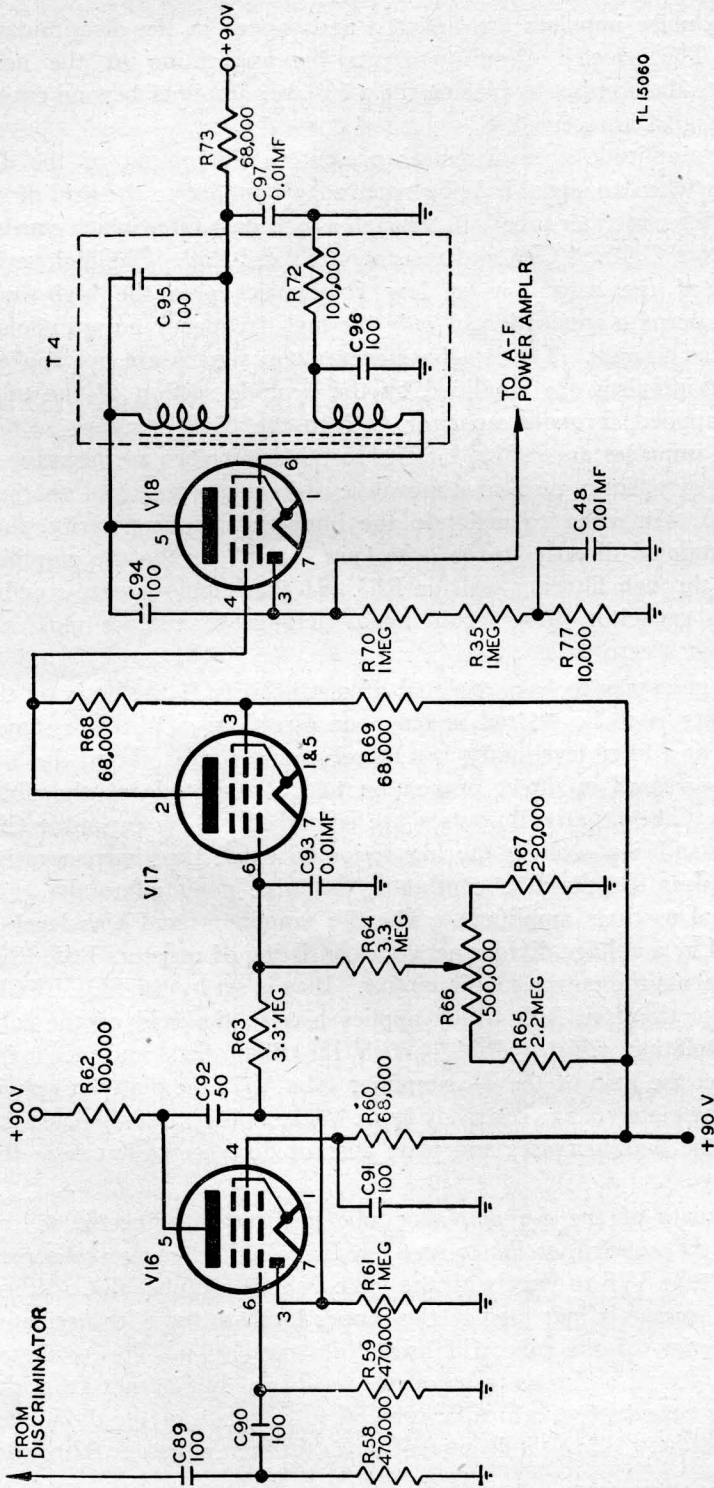

TL 15060

Figure 51. Radio Receiver and Transmitter BC-1000-A,  
noise squelch circuit.

amplitude noise impulses are detected and appear in the discriminator output. The squelch circuit prevents the application of the noise impulses to the handset by biasing the a-f power amplifier beyond cut-off when no signal is received.

b. The amplitude noise impulses present in the output of the discriminator when no signal is being received are applied to the grid of the noise amplifier rectifier tube V16 through a high-pass filter which consists of capacitors C89 and C90, and resistors R58 and R59. The high-series reactance of the capacitors at low frequencies plus the high-shunt resistance permits application of only the high-frequency noise impulses to the noise circuits. The low-frequency audio signals are not applied. The noise impulses are amplified by the pentode section of the tube, and are applied through capacitor C92 to the diode rectifier section where the impulses are rectified. The rectified impulses are negative in polarity (vary from zero to a negative voltage proportional to their amplitude). In order to maintain the impulses of one polarity, they must be coupled directly to the grid (pin No. 6) of the d-c amplifier tube V17 through filtering resistor R63. If the impulses were coupled through a capacitor, they would again arrange themselves plus and minus about a zero axis.

c. It is necessary to have a signal of one polarity if the basis on the d-c amplifier is to be shifted in only one direction. (With no signal, bias is set at a fixed level and when noise impulses are received the bias must be *increased* in direct proportion to the amplitude of the noise impulses.) The negative impulses are smoothed out by capacitor C93 which has sufficient voltage storing action to cause the sharp negative noise impulses to present a continuous negative potential to the grid; proportional to their amplitude. The d-c amplifier fixed bias level is established by a voltage divider network consisting of resistors R65, R66, and R67 across the power supply circuit. Bias is set by the SQUELCH control potentiometer R66 which applies bias to the grid of the tube through isolating resistor R64. With the fixed bias and no noise impulses on the grid of the d-c amplifier tube V17, the plate current is high and the plate voltage relatively low. When noise impulses reach the amplifier, the bias increases and plate current decreases, increasing the plate voltage.

d. The plate of the *d-c amplifier* tube is directly connected to the screen of the *squelch oscillator-rectifier tube* V18, causing the screen voltage of tube V18 to vary with the plate voltage of tube V17. When the screen voltage is increased to the proper level, the squelch oscillator pentode section of the tube will break into oscillation. The oscillator operates at 400 kc and uses transformer feedback. R-f output from the oscillator is coupled through capacitor C94 to the plate of the diode section of the tube. When diode current flows through resistors R70, R35,

and R77, a negative voltage is developed which will bias the a-f power amplifier grid beyond cut-off. The following parts are also contained in the noise circuit: grid resistors R59 and R72, screen resistors R60 and R69, screen bypass capacitor C91, plate load resistors R62 and R68, decoupling resistor R73, plate bypass capacitor C97, diode load resistor R61, tuning capacitors C95 and C96, iron-core inductor, and bypass capacitor C48.

## 82. Transmitter Circuit Features

The transmitter of Radio Receiver and Transmitter BC-1000-A, as shown in figure 52, consists of the previously described master oscillator (V4) and doubler (V3) (par. 74), transmitter mixer and crystal oscillator, and tuned circuits of the r-f power amplifier. The master oscillator is frequency modulated by the reactance modulator V5. In transmitting, the output of the doubler is *added* to the transmitter

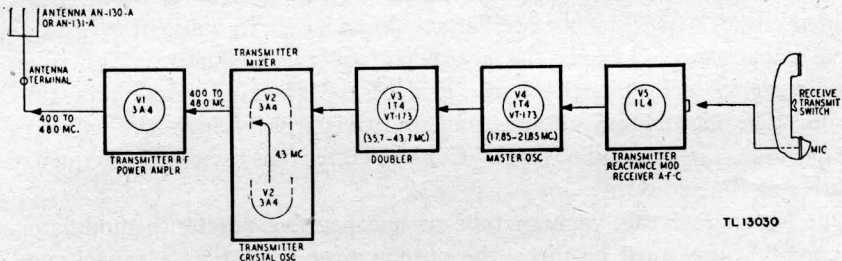

Figure 52. Radio Receiver and Transmitter BC-1000-A, transmitter—block diagram.

crystal oscillator frequency to produce the final transmitter frequency. As a special aid in alignment procedure and operational checks, a switch marked PRESS FOR DIAL LIGHT & CALIB. turns on the transmitter mixer and crystal oscillator V2.

## 83. Reactance Modulator

a. The reactance modulator Tube JAN-1L4, V5, shown in figure 53, changes the frequency of the master oscillator (V4) in accordance with changes in voltage of the audio signal applied to its control grid. The greater the amplitude of this audio modulating signal, the greater is the frequency deviation on each side of the resting frequency. The higher the audio frequency, the *more often* the frequency deviates on each side of the resting frequency. The audio signal is applied to the grid of the reactance modulator tube V5 by microphone transformer T3A and blocking capacitor C29. The transformer secondary is shunted by resistor R20 to place a more constant load on the microphone circuit and to reduce any audio howl. R17 is an isolating resistor in the control grid circuit.



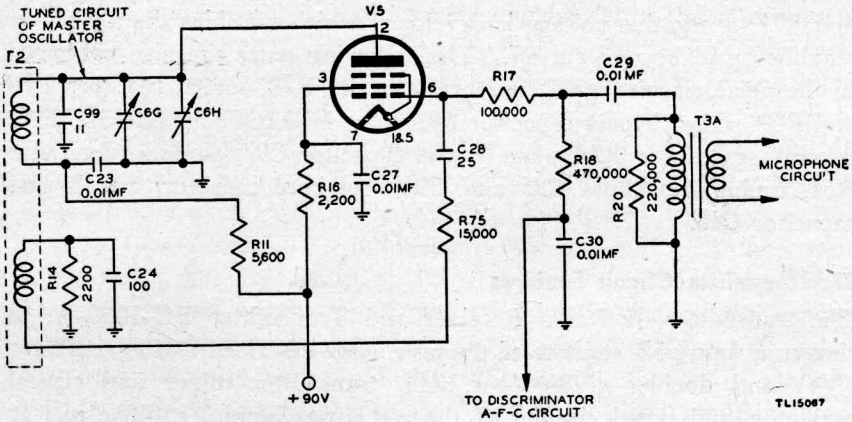

Figure 53. Radio Receiver and Transmitter BC-1000-A, reactance modulator.

b. The reactance modulator tube is an electronic capacitor shunting the tuned circuit of the master oscillator. Any change in value of this effective capacitance changes the frequency of the oscillator. When an audio signal is impressed on the grid of the reactance modulator tube from the microphone circuit, the a-c variations change the effective capacitance at an audio rate. Consequently the oscillator frequency varies at the same rate.

c. To operate this vacuum tube as a capacitive reactance modulator, two conditions must be met: the output must appear as a capacitance, or the plate voltage across the output must lag the plate current by  $90^\circ$  (the voltage across a capacitor lags the current by  $90^\circ$ ); and the value of the effective capacitance must vary in accordance with the change in grid potential.

(1) Figure 54 shows how the first condition is met. The r-f voltage developed across the tuned circuit L1-C1 (the tuned plate circuit of the master oscillator) induces a voltage  $180^\circ$  out of phase in grid coil L2 (the grid feedback coil of the master oscillator). A network consisting of resistor R75 and the interelectrode capacitance  $C_{gf}$  between the grid

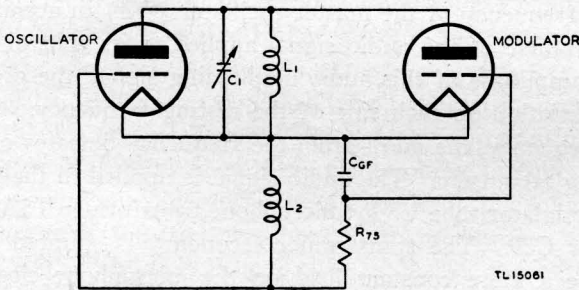

Figure 54. Radio Receiver and Transmitter BC-1000-A, reactance modulator, simplified a-c-schematic.

and the filament of the reactance modulator tube is connected across the inductor L2. Since the resistance of resistor R75 is high in comparison with the reactance of  $C_{gf}$  at the oscillator frequency, the current through the series combination is almost in phase with the induced voltage of the coil. But the voltage across the interelectrode capacitance  $C_{gf}$  lags the current by  $90^\circ$ . This is the grid voltage applied to the reactance modulator tube, and it lags the voltage across the tuned circuit (or the plate voltage) by a total of  $270^\circ$  ( $180^\circ$  plus  $90^\circ$ ). This is the same as saying that the reactance modulator tube grid voltage leads the plate voltage by  $90^\circ$ . Since the reactance modulator tube plate current is in phase with the grid voltage, the plate current contributed to the tuned circuit by the reactance modulator tube leads the plate voltage by  $90^\circ$ , forming an effective capacitance.

(2) The second condition, that effective capacitance must be variable in accordance with the change in grid potential of the modulator tube, is met by controlling the amount of plate current contributed by the reactance modulator tube. During modulation the grid of the reactance modulator tube is swung about its operating point by the applied audio signal. These audio signal variations on the grid cause corresponding variations in the plate current, in capacitance across the oscillator tank, and in oscillator frequency. The larger the amplitude of the signal variations impressed on the grid, the greater will be the plate current variations and the farther the master oscillator frequency will swing above and below the resting frequency.

d. The reactance modulator tube serves also as an automatic frequency control device (par. 80). Other parts of the reactance modulator tube circuit are blocking capacitor C28, screen resistor R16, screen bypass capacitor C27, master oscillator tuned circuit consisting of air core inductor, tuning capacitor C6H, trimmer capacitor C6G, temperature compensating capacitor C99, and plate bypass capacitor C23, plate decoupling resistor R11, control grid resistor R17, oscillator grid resistor R14, oscillator grid resistor bypass capacitor C24, audio coupling capacitor C29, microphone transformer T3A, and shunt resistor R20.

#### 84. Transmitter Mixer and Crystal Oscillator

a. The transmitter mixer and crystal-oscillator Tube JAN-3A4, V2, as shown in figure 55, generates a crystal-controlled frequency which is combined with the output of the doubler stage in the mixer section of the tube.

The mixer tuned output circuit is resonant at the *sum* frequency. The crystal oscillator section of the tube is a triode oscillator on 4.3 mc with the screen grid of the pentode used as the plate of the oscillator. The tuned circuit of the oscillator consists of fixed capacitor C13 and tunable iron-core inductor L3. The relative value of the Class C grid

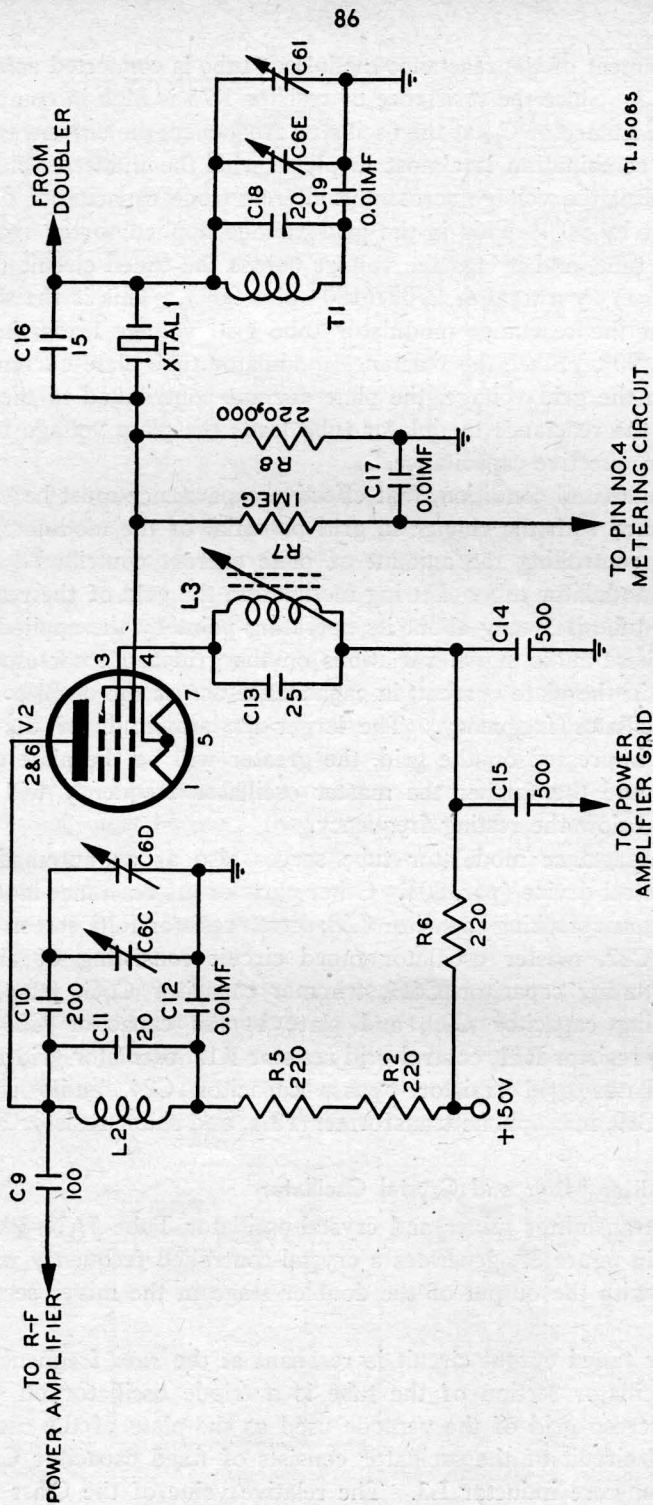

Figure 55. Radio Receiver and Transmitter BC-1000-A, transmitter mixer and crystal oscillator.

TL15065

bias developed by the flow of rectified grid current through resistor R8 is measured at pin No. 4 of the metering socket. A decoupling network consisting of resistor R7 and capacitor C17 keeps radio frequency out of the metering circuit and prevents the metering circuit from loading the r-f stages of the transmitter. Doubler output is injected into the control grid (pin No. 6) of the mixer tube V2 through capacitor C16. The two signals are mixed in the electron stream and the *sum* frequency is brought out by the tuned mixer circuit consisting of inductor L2, tuning capacitor C6D, trimmer capacitor C6C, temperature compensating capacitors C10 and C11, and bypass capacitor C12. The output of the mixer is coupled to the grid of the power amplifier through capacitor C9. R2, R5 and R6 are decoupling resistors. Capacitor C14 is a B+ bypass capacitor. The double tuned plate circuit consists of an air-core inductor, and associated capacitors C18, C19, C6E, and C6F.

b. A special test switch (PRESS FOR DIAL LIGHT & CALIB.) in the filament circuit of the transmitter mixer and crystal-oscillator tube V2 places the tube in operation. When it is closed a number of receiver alignment and check operations can be made.

(1) The set can be calibrated by pressing the PRESS FOR DIAL LIGHT & CALIB. button. Present in the screen grid circuit of the transmitter mixer and crystal-oscillator tube are the 10th and 11th harmonics of the crystal oscillator (43 mc and 47.3 mc) plus a small value of output voltage in the same frequency range. At the points where the harmonics of crystal XTAL 1 and the output of the transmitter mixer are almost the same frequency, an audible beat note is produced which is coupled to the grid of the a-f power amplifier tube V15 through capacitor C15. The audible beat note obtained at these frequencies is useful in aligning the master oscillator and calibrating the tuning dial.

(2) The discriminator can be aligned. When the test switch is closed, a portion of the 4.3-mc signal leaks into the first i-f amplifier system. This signal is converted in the second mixer to the frequency of the second i-f amplifier system and is applied to the discriminator where it can be used to set the discriminator on the exact intermediate frequency.

(3) An external signal generator can be set exactly to a frequency of 4.3 mc for alignment of the i-f amplifier stages.

(4) All stages except the final transmitter stage can be tuned without radiating any r-f energy.

### 85. Radio-frequency Power Amplifier

The r-f power amplifier Tube JAN-3A4, V1, as shown in figure 56, is a Class C r-f amplifier which increases the output of the transmitter mixer before it is applied to the antenna. The tuned circuit of the r-f power amplifier is common to both receiver and transmitter. A portion of the r-f output energy is coupled to the receiver input through capacitor C2.

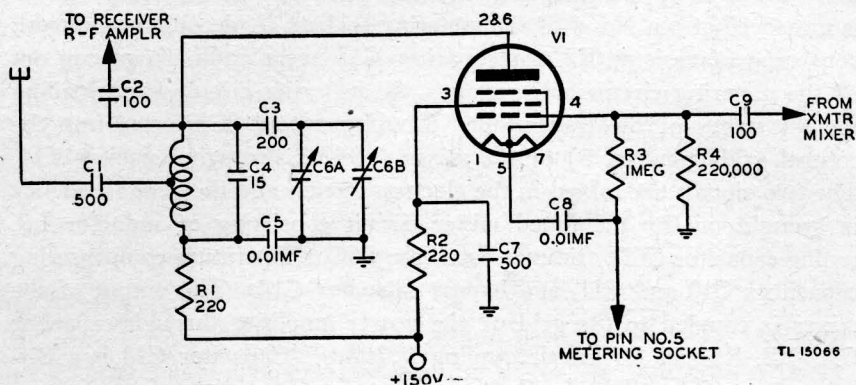

Figure 56. Radio Receiver and Transmitter BC-1000-A, r-f power amplifier.

The small value of signal that gets through the receiver is used to provide sidetone during transmission. The discriminator is held inoperative during transmission by the strong 4.3-mc signal which leaks into the first i-f amplifier circuits from the 4.3-mc crystal oscillator. A relative indication of the r-f power amplifier grid bias developed across R4 is measured at pin No. 5 of the metering socket. Other parts of the r-f power amplifier are decoupling resistor R1, plate bypass capacitor C5, screen grid resistor R2, screen grid bypass capacitor C7, coupling capacitor C9, meter filter circuit resistor R3 and capacitor C8, antenna coupling capacitor C1, and the tuned plate circuit consisting of an air core inductor and associated capacitors C3, C4, C5, C6A, and C6B.

## 86. Antenna Circuit and Operation

The following antennas can be used with Radio Receiver and Transmitter BC-1000-A: Antenna AN-130-A, Antenna AN-131-A, or Antenna Equipment RC-291-( ).

a. ANTENNA AN-130-A. This antenna which is 33 inches long and has two sections held together by a stainless steel cable, is provided with

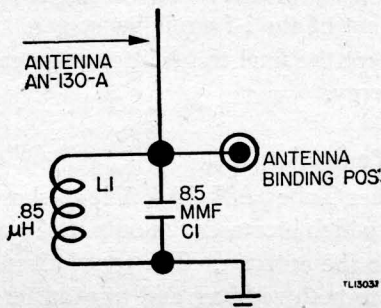

Figure 57. Antenna AN-130-A, antenna shunt circuit within base.

a flexible gooseneck so that it can be kept in a vertical position. A bakelite shell houses an antenna coil and capacitor. This coil L1 and capacitor C1 (fig. 57) are arranged in a parallel or shunt circuit between the antenna and ground, and present a reactance opposite to that presented by Antenna AN-130-A to tube VI of the radio receiver and transmitter. This action permits tracking of the final amplifier stage of the radio set without further adjustment when Antenna AN-130-A is used. Coil L1 has an inductance of 0.85 uh and capacitor C1 has a capacitance of 8.5 mmf. The two sections of Antenna AN-130-A are at no time resonant at the operating frequency.

b. ANTENNA AN-131-A. This antenna is 10 feet, 8 inches long and acts as a vertical radiator resonant at the mean frequency (44 mc) used by the radio receiver and transmitter. It is coupled to the plate tank circuit of the final amplifier by capacitor C1 (fig. 58) which has a value of 500 mmf and offers little reactance at the frequencies used. The function of capacitor C1 is to keep the d-c plate voltage present on L1 from appearing on the antenna proper.

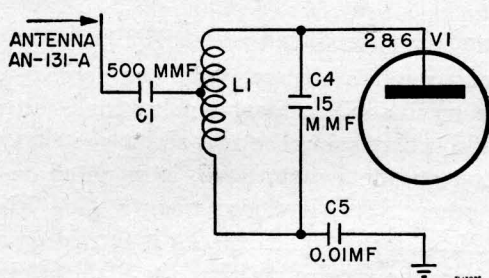

Figure 58. Antenna AN-131-A, coupling circuit.

c. ANTENNA EQUIPMENT RC-291-( ). This antenna, not supplied as part of Radio Set SCR-300-A, consists of a ground plane antenna resonant at the mean frequency (44 mc) used by the radio set. The four radials supplied with the antenna are connected to the outer sheaf of Cord CG-102/TRC-7 and act as a ground plane to concentrate radiation at the horizon, thus providing greater range. The characteristic impedance of Cord CG-102/TRC-7 matches the average impedance of the quarter-wave vertical rod at the frequencies used. The cord itself neither radiates nor absorbs radio signals from the air. This action of the cord permits the antenna to be elevated while the set remains on the ground. The range obtainable with Antenna Equipment RC-291-( ) increases with the elevation of the antenna above ground. This range can be calculated approximately by the formula  $R=1.42\sqrt{h}$  where  $R$  is the range in miles and  $h$  is the height in feet of the quarter-wave antenna above the ground. Screening objects such as mountains

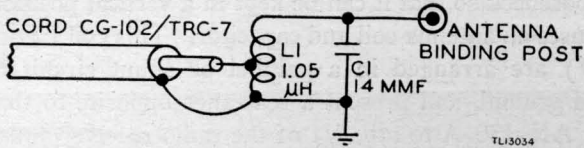

Figure 59. Antenna Equipment RC-291-( ), coupling circuit.

or trees higher than the elevated antenna will cut this range. Cord CG-102/TRC-7 is directly coupled to inductor L1 (fig. 59) at a point where the 50-ohm impedance of the cord matches the impedance of the section of the coil across which the cord is bridged. Coil L1 and capacitor C1 act as an autotransformer. An impedance of approximately 2,400 ohms appears at the antenna binding post, and decreases to zero (approximately) at the grounded end of the coil. L1 and C1 resonate at 40 mc and serve as a tracking network. L1 has an inductance of 1.05 uh; C1 has a capacitance of 15 mmf. L1 and C1 are housed in Terminal Box TM-217 which screws into the antenna terminal on the set.

### 87. Receive-transmit Control Circuit

The control circuit permits change-over from receive to transmit and from transmit to receive with a double-pole, single-throw switch. The receiver is turned on by closing the two series switches which complete the filament circuits. One switch, SW2, is mounted on the VOLUME control and the other, SW1, is closed when a plug PL-55 is inserted in the PHONE No. 1 jack. When the set is turned on and the receive-transmit switch is in the receive position, the filament circuits of the r-f power amplifier tube (V1) and of the transmitter mixer tube (V2) are not completed to ground. The transmitter is inoperative. When the receive-transmit switch is depressed, the transmitter filament circuit is completed. When the handset is used a 750-ohm resistor is shunted across the receiver unit to reduce side-tone when the receive-transmit switch is depressed. Microphone current is obtained from a 4.5-volt point on the battery which is shunted by a series network consisting of resistor R21, the primary of the microphone transformer T3A, and the microphone.

### 88. Metering Circuit

Metering socket SO1, mounted on the side of the chassis of Radio Receiver and Transmitter BC-1000-A, is used for alignment and test purposes. An electronic voltmeter must be used in making measurements to prevent loading of the high impedance circuits. Measurements are made by attaching the voltmeter between the correct pin and ground. Pin numbers and their corresponding circuits are as follows:

<i>Pin No.</i>	<i>Voltage</i>
1 .....	Master-oscillator grid.
2 .....	First limiter grid.
3 .....	Second limiter grid.
4 .....	Transmitter mixer grid.
5 .....	Transmitter r-f power amplifier grid.
6 .....	Receiver r-f amplifier grid.
7 .....	Discriminator output.
8 .....	Ground or chassis.

### 89. Filament Circuits (fig. 88)

In order that 1.5 volts can be applied to each filament from the 4.5-volt supply, the filaments of the tubes in Radio Receiver and Transmitter BC-1000-A are arranged in a series-parallel connection. Capacitors C71, C74, C75, C76, C77, C78, C79, C80, C81, C82, C83, C84, C85, C86, C87 and C88 provide low-impedance paths to ground for r-f current, where necessary. Choke CH1 through CH9, connected in series with filament circuits, isolate r-f currents from the circuits in which they are not desired. Because of the voltage drops in the filament circuit, each control grid has an effective fixed bias of one-half the voltage drop across the tube filament plus the voltage drop across the filaments of all other tubes between it and ground. Resistor R22 is a shunt resistor across the filament of tube V1. R76 is a shunt resistor across the filament of tube V4, the transmitter and receiver oscillator. Resistor R76 lowers the filament current and emission, and improves the oscillator stability. Resistor R56 is a dial light shunting resistor and resistor R57 is a filament voltage dropping resistor.

### 90. Battery Circuit

The voltages used by the various circuits of Radio Receiver and Transmitter BC-1000-A are supplied by Battery BA-70 or BA-80. Filament voltage for both receiver and transmitter and microphone current are supplied by a 4.5-volt section. The receiver and a portion of the transmitter circuit use the 90-volt section for plate and screen supply. Plate and screen voltage for the transmitter r-f power amplifier and for the transmitter mixer and crystal oscillator is supplied by a 150-volt source (90-volt section in series with a 60-volt section).

### 91. Modifications during Manufacture

*a.* CHANGE OF CAPACITORS C5, C12, AND C72. To decrease the possibility of voltage break-down, capacitor C5, which is the plate bypass capacitor for the r-f amplifier tube V1, and capacitor C12, which is the plate bypass capacitor for transmitter mixer tube V2, have both been changed from a 400-volt rating to 500 volts. Capacitor C72, a 0.006



mmf, 400-volt, molded paper capacitor, has been replaced by a 0.006 mmf, 500-volt, molded mica capacitor. C72 is shunted across the primary of output transformer T3B. These changes are effective on all sets on Order No. 10185-Phila-44-01 after Serial No. 5800, and all of Order No. 23916-Phila-44-01.

*b. CHANGES TO INCREASE GAIN OF THIRD INTERMEDIATE-FREQUENCY STAGE* (fig. 88). The following changes are incorporated in Radio Set SCR-300-A beginning with Serial No. 6500 on Order No. 8558-Phila-44-01 and effective on Order No. 10185-Phila-44-01 after Serial No. 5800 and all Serial Nos. between 4625 and 4935, inclusive. This change has been made to permit the use of most tubes that are within JAN specifications without tube selection.

(1) R41, the plate and screen-grid voltage-dropping resistor for the third i-f amplifier tube V11, has been changed from 22,000 ohms, 1/3 watt, to 15,000 ohms, 1/3 watt. This change results in a higher plate and screen-grid voltage applied to tube V11, which increases the amplification of this stage.

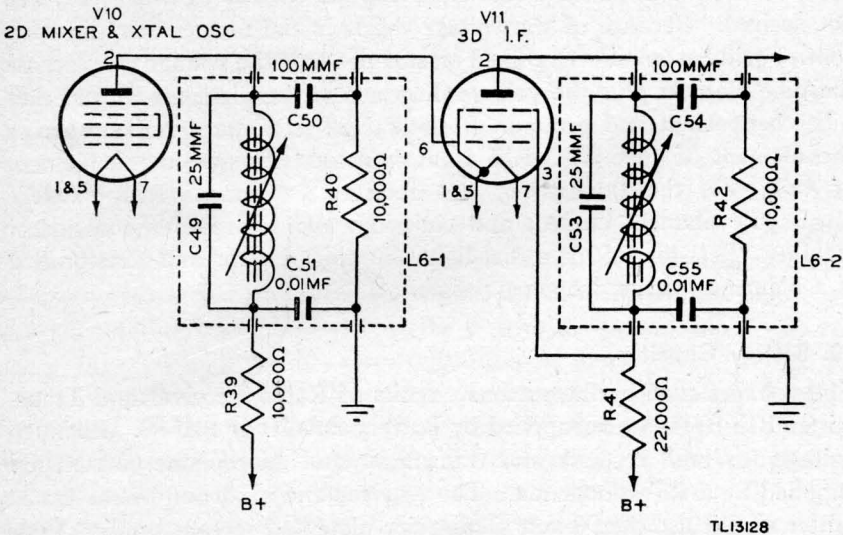

Figure 60. Third i-f amplifier, before circuit change.

(2) The grid-return resistor R40 of the third i-f amplifier tube V11 is connected to the positive filament leg, terminal No. 7, of the second mixer and oscillator tube V10. In this manner the grid bias of the third i-f amplifier tube V11 is reduced from a minimum of  $1\frac{1}{2}$  volts, which increases the amplification of the stage. Figure 60 shows the circuit of the third i-f amplifier before the change was made. The above changes also apply to Order No. 29316-Phila-44-01.

*c. REVISION OF FIFTH FILAMENT STRING.* The arrangement of the

fifth filament string has been changed to improve the operation of the set. Figure 61① shows the arrangement of the filaments before the change while figure 61② shows the filament string after the change. The string has been revised to put the filament of doubler tube V3 at the ground end of the string. This filament revision is effective on all sets on Order No. 15025-Phila-43 from Serial Nos. 4775 through 8824 and from 9111 through 14707. It is also effective on all sets on the entire Order No. 32870-Phila-43, Order No. 23916-Phila-44-01, and Order No. 10185-Phila-44-01.

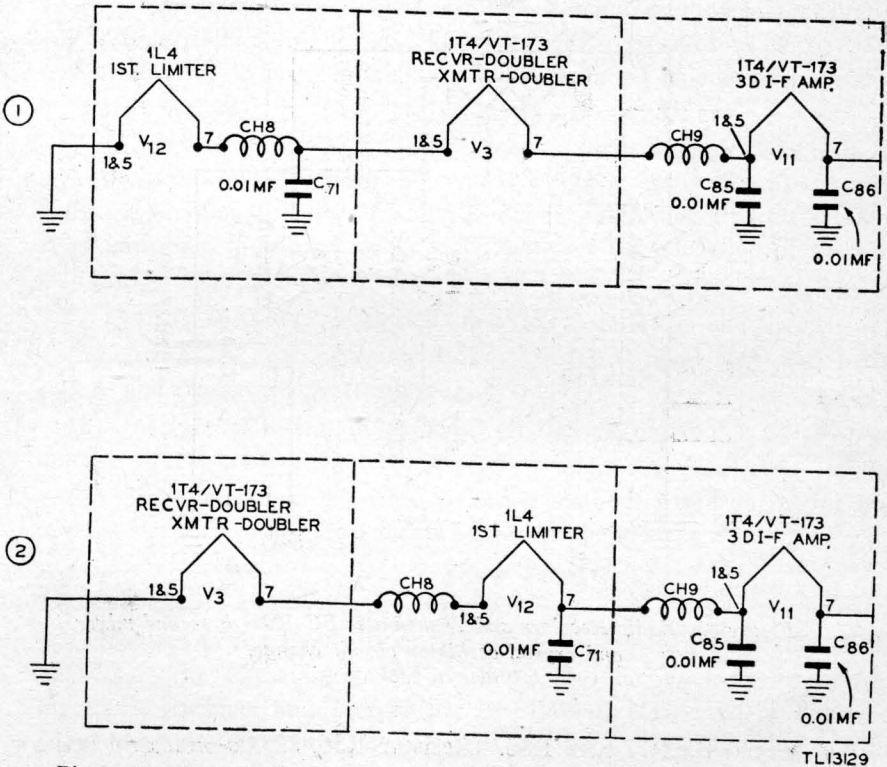

Figure 61. Radio Receiver and Transmitter BC-1000-A, wiring change in filament circuit of tubes, V3, V11, and V12.

d. CAPACITOR C98. Capacitor C98 is connected from the anode grid, pin No. 3, of the second mixer and crystal-oscillator tube V10 to ground (fig. 62) in all sets on Order No. 15025-Phila-43 from Serial No. 2601 through 8824, approximately. It is omitted from all other sets which have Serial Nos. below 2601 and above 8824, as well as all sets on Order Nos. 32870-Phila-43, 10185-Phila-44-01, and 23916-Phila-44-01.

e. CAPACITORS C99 AND C22. Capacitor C22 (8.5 mmf) is used only on radio sets bearing Serial No. 1 through 4401 on Order No. 15025-Phila-43. In all other sets, C22 has been replaced by C99 which has a

capacity of 11 mmf. This change is effective on all sets on Order No. 15025-Phila-43 from Serial No. 4402 and above, as well as on the entire Order No. 10185-Phila-44-01. C22 (or C99) is connected between the top end of the primary of transformer T2 and ground. The above changes also apply to Order No. 29316-Phila-44-01.

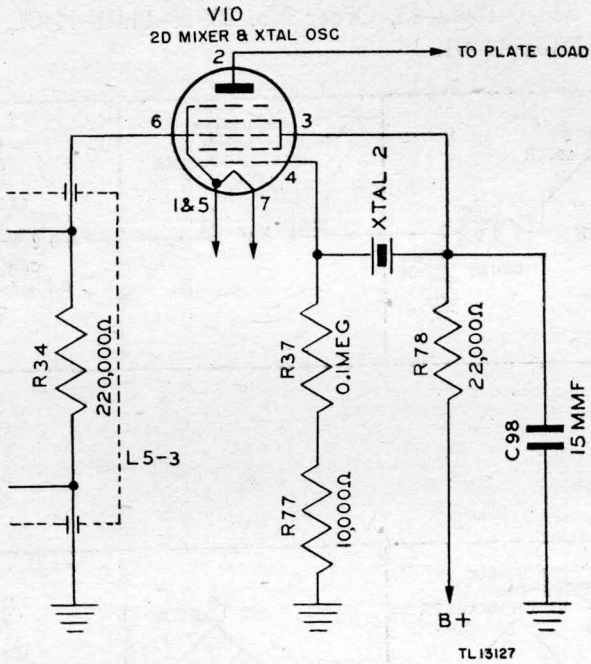

Figure 62. Radio Receiver and Transmitter BC-1000-A, second mixer and crystal-oscillator circuit change.

f. RESISTORS R77 AND R36. Resistor R36, 22,000-ohm grid resistor of oscillator tube V10, is used in all sets on Order No. 15025-Phila-43 bearing Serial Nos. from 1 through 8823. In all sets above Serial No. 8823 and in all those on Order Nos. 32870-Phila-43, 10185-Phila-44-01, and 23916-Phila-44-01, resistor R36 has been replaced by Resistor R77 (10,000 ohms).

g. RESISTORS R78 AND R38. Resistor R38 is a 39,000-ohm screen-grid voltage-dropping resistor for tube V10 used only in sets bearing Serial Nos. 1 through 8823 on Order No. 15025-Phila-43. Resistor R78, 22,000 ohms, replaces resistor R38 in all sets on Order No. 15025-Phila-43, above Serial No. 8823, as well as in all sets on Order Nos. 32870-Phila-43, 10185-Phila-44-01, and 29316-Phila-44-01.

## Section II. TROUBLE SHOOTING

### 92. Introduction

The proper operation of radio equipment is a vital factor in the coordination of troop movements and activities in combat areas. When failure occurs, the equipment must be restored to normal operation in the shortest time possible. A logical, rapid, systematic method of procedure for trouble shooting is outlined in section III. Paragraphs 96 to 100, inclusive, describe a systematic method for isolating trouble to a specific section of the set.

*a. THEORY OF EQUIPMENT.* To perform efficient repair on a unit, a thorough knowledge of how and why it works is essential. Study and learn the functional theory of Radio Receiver and Transmitter BC-1000-A as explained in section XIV, which analyzes the operation of the set in a logical step-by-step sequence.

*b. TESTING METHODS.* Methods used are:

(1) Analytical and inspection techniques based upon stop-start procedure and equipment performance.

(2) Instrument test methods based on the use of trouble charts and voltage or resistance measurements.

(3) Signal tracing or signal substitution methods based on tracing an applied signal through the various stages of the set.

### 93. Maintenance Equipment (fig. 63)

*a. MAINTENANCE EQUIPMENT ME-40-( ) AND MAINTENANCE KIT ME-53-( ).* These are packed in Chest CH-165. Their use in servicing Radio Receiver and Transmitter BC-1000-A is covered in TM 11-315. Alignment procedures are given in section V. The following equipment is required:

(1) Phantom Antenna A-28-( ).

(2) Alignment Indicator I-210-( ).

(3) Oscillator VO-6-( ).

(4) Tube Puller TL-201.

(5) Spintite wrench,  $\frac{3}{8}$  inch.

(6) Screw driver TL-15.

(7) Alignment tool.

(8) Battery Cable Assembly CD-1108.

(9) 1 case spare tubes.

b. ALTERNATE EQUIPMENT AND MISCELLANEOUS TOOLS. (1) Frequency Meter Set SCR-211-( ), or accurate signal generator having a 4.3-mc output.

(2) Electronic voltmeter, range 6 to 50 volts.

(3) Combination d-c voltmeter and ohmmeter, range 0 to 150 volts.

(4) Soldering iron with small tip.

(5) Long-nose pliers, one pair.

(6) Diagonal cutting pliers, one pair.

c. TEST SET I-56-( ). This equipment is issued using units as a general test set, and contains a tube checker, set analyzer, voltohmmeter, and an output meter. The use of this equipment is fully described in TM 11-303, 11-321, 11-2613, 11-2626, and 11-2627.

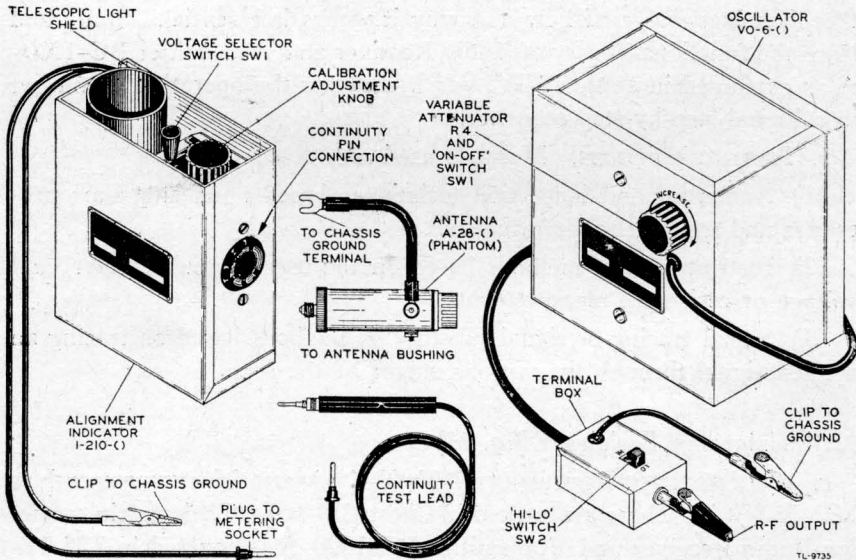

Figure 63. Maintenance Equipment ME-40-( ), basic components.

### Section III. TROUBLE-SHOOTING PROCEDURES

#### 94. Purpose

The importance of keeping Radio Set SCR-300-A in operation has been discussed in a previous section. The following procedures will aid in making rapid and accurate repairs.

a. When equipment becomes defective or inoperative, it is recommended that the following trouble shooting procedure be adopted.

- (1) Be certain that the VOLUME control is turned on.
- (2) Be certain that the SQUELCH control is turned OFF.
- (3) Be certain that Plug PL-55 of the handset or headset is plugged *all the way* into PHONE No. 1 jack.
- (4) If the headset is used alone, replace with the handset or vice versa, since the particular unit used may be defective.
- (5) Be certain that the battery plug contacts are clean and are plugged in as far as they will go.
- (6) The set may be inoperative due to a run-down battery; therefore, as a check, replace with a fresh unit.

b. Attempt to localize the trouble by examining the equipment carefully, noting abnormal effects. To analyze and inspect without test equipment, proceed as follows:

(1) Remove the chassis from the case and examine the wiring for poorly soldered connections, damaged wiring, parts shorting against each other or against the chassis case, and bad sockets or socket connections. Make certain tubes are not cracked or broken and that they are plugged all the way into their proper sockets.

(2) Examine for component parts which appear abnormal such as *bloated* capacitors, charred or broken resistors, broken sockets, tubes, controls, etc.

(3) If no tube checker or continuity checker is available, replace the tubes one at a time with others known to be in good condition.

(4) Feel the various components for signs of excessive heating.

(5) Shorted parts or any part through which excessive current is passing will usually give off a strong odor. Examine for the presence of unusual odors.

(6) Listen for excessive hum, distortion, fading, etc.

(7) Inspect the antenna for correct position and for freedom from local interference, such as high tension wires, power plants, and other electrical equipment. Make certain that the antenna is vertical and is not touching overhanging eaves, wiring, or branches.

c. If the above methods have failed to localize the trouble, test equipment must be used.

## 95. Instrument Test Methods

a. PRELIMINARY PRECAUTIONS. (1) Do not check filament continuity with an ohmmeter unless the highest scale is used.

(2) Do not remove tubes unless there is an indication that one or more is defective.

(3) When using a test prod to take voltage measurements, cover most of the prod with tape so that only the point is exposed. This prevents short circuits.

(4) Before connecting Battery BA-70 or BA-80, always check for shorts between A positive and the high-voltage prongs on the power input plug. There should be more than 500,000 ohms resistance.

(5) Before repairing a set, get the operator's report on the trouble, but do not depend entirely on this report.

(6) Always check alignment of set before removing circuit elements.

(7) Never replace any tube or circuit element until cause or failure of the damaged element has been determined and corrected.

*b. GENERAL.* After the trouble has been localized to one section of the set, use test instruments to find the exact part causing the trouble. To assist the repairman in testing the set, tables of normal values of resistance and voltages are provided in paragraphs 98, 99, and 100. Resistance tables indicating the resistance between socket contacts and ground, and between terminals and ground are furnished. Also voltage test tables are supplied which indicate voltages from all sockets to ground, and all terminals to ground.

*c. SIGNAL TRACING AND SUBSTITUTION.* Signal tracing and signal substitution may be used to localize trouble that cannot be found by voltage and resistance checks. A voltage and frequency chart is furnished in section IV. For further information and instructions in the use of test instruments involved in resistance and voltage measurements, and for signal generators and other instruments used in signal tracing and signal substitution, see Technical Manuals supplied with these instruments.

## **96. Start-Stop Procedure**

*a. PREPARATION.* Assemble the set with the handset, headset, and antenna.

*b. ANALYSIS.* Turn VOLUME control and SQUELCH control to the extreme counterclockwise position. The step-by-step procedure of the start-stop method is given in table IX.

Table IX. Start-stop Trouble Analysis

Step No.	Action	Normal indications	Abnormal indications	Probable cause of trouble
1	Turn VOLUME control on, with SQUELCH control in extreme counterclockwise position.	Click heard in handset. Rushing sound heard.	No click. No rushing sound.	VOLUME control switch defective. Plug PL-55 not inserted in PHONE No. 1 jack properly. Switch on handset held in transmit position. Handset cords defective. Battery weak or dead. Battery cable plug poorly connected. Battery cable defective. Gear teeth on dial worn or broken.
2	Release DIAL LOCK and turn TUNING knob.	Dial moves easily in either direction.	Dial does not move.	Dial lamp burned out. Calibration switch SW3 defective. Filament circuit of transmitter mixer tube V2 open. Capacitor C88 shorted. Resistor R56 shorted or open.
3	Press PRESS FOR DIAL LIGHT & CALIB. button.	Dial lamp lights dimly.	Dial lamp does not light.	
4	Tune to calibration mark C between channels 36 and 37. Press PRESS FOR DIAL LIGHT & CALIB. button.	Beat note heard on each side of calibration mark; zero beat at calibration mark.	No beat note.	Handset defective. Resistor R56 defective. Tube V2, or tube circuits defective. 4.3-mc crystal defective. Calibration inaccurate.
5	Tune to correct channel to receive desired signal.	Signal heard clearly on correct channel.	Signal heard on wrong channel.	Calibration inaccurate.



Table IX. Start-stop Trouble Analysis

Step No.	Action	Normal indications	Abnormal indications	Probable cause of trouble
6	Press receive-transmit switch on handle of handset.	Rushing noise stops.	Rushing noise continues.	Handset or transmit-receive switch defective.
7	Turn SQUELCH control clockwise slowly.	Click heard.	No click.	Plug PL-68 or MIC. jack defective.
		Noise stops.	Noise persists.	Transmitter tubes V1 or V2, or tube circuits defective.
8	Turn SQUELCH control off.	Rushing noise heard in headset.	No rushing noise.	Squelch tubes V16, V17, or V18, or tube circuits defective.
9	Check reception for range and clarity.	Reception good at 3-mile range.	Signal weak.	Connections loose in headset cord, junction box, or AUX. PHONE jack. Headset defective.
			Distortion.	Location poor. Antenna shorted, defective, or not vertical. Antenna AN-130-A not grounded. Receiver not properly tuned. Calibration inaccurate. Battery weak. Receiver tubes weak. Receiver misaligned.
			Noise.	Battery weak. Receiver misaligned. Calibration inaccurate. Nearby electrical equipment (motors, generators, power lines, ignition systems, etc.).

Step No.	Action	Normal indications	Abnormal indications	Probable cause of trouble
10	Check transmission for range and clarity.	Signal good at 3-mile range.	Reception intermittent. Signal weak.	Leads or connections loose or broken. Plugs not tight in jacks. Headset or handset receiver unit defective. Location poor. Antenna shorted, defective, or not vertical. Antenna AN-130-A not grounded. Microphone in handset defective. Battery weak. Transmitting tubes weak. Transmitter misaligned. Operator too far from microphone.
11	Turn SQUELCH control OFF.	Noise level increases.	Distortion. Transmission intermittent.	Operator using microphone improperly. Battery weak. Leads or connections loose or broken. Plugs not tight in jacks. Microphone defective. Receive-transmit switch defective. SQUELCH circuit defective.
12	Turn VOLUME control OFF.	Click heard. Volume level decreases steadily. Click heard.	No click. Volume level unchanged. No click.	SQUELCH control switch defective. VOLUME control defective. VOLUME control switch defective.

### 97. Reference Trouble Chart

As an aid in finding troubles in Radio Set SCR-300-A, the following chart (table X) is supplied for reference. It covers a number of common troubles that develop in the use of Radio Set SCR-300-A.

Table X. Trouble Shooting

Symptom	Probable trouble	Correction	
Receiver dead.	Power switch OFF.	Turn VOLUME control to the right.	
	No phone plug in PHONE No. 1 jack.	Plug phone into PHONE No. 1 jack.	
	SQUELCH control advanced too far.	Adjust SQUELCH. (See par. 27e.)	
	Open phone plug in RELAY jack.	With no automatic relay equipment connected to the set, no plug should be in RELAY jack.	
	Set always transmitting.	Replace handset. Receive-transmit switch defective.	
	Off calibration.	Recalibrate. (See par. 26d.)	
	Defective handset or headset.	Replace.	
	Dead or low Battery BA-70 or BA-80.	Replace battery. (See par. 108.)	
	Antenna insulator shorted by water or dirt.	Wipe off insulator.	
	Antenna touching metallic material or wet foliage.	Keep antenna clear.	
	Defective or burned out tube.	Replace. (See par. 104.)	
	Defect in squelch circuit.	Turn squelch OFF.	
	Weak receiver.	Receiver not tuned.	Reset dial. (See par. 27.) Recalibration may be necessary.
		Improper calibration.	Recalibrate. (See par. 26d.)
Weak Battery BA-70 or BA-80.		Replace battery. (See par. 108.)	
Antenna AN-130-A used without ground connection.		Check ground connection or replace.	
High resistance short across antenna insulator caused by water or dirt.		Wipe off antenna insulator.	
Defective antenna.		Replace antenna.	
Antenna touching metallic material or wet foliage.		Keep antenna clear.	
Receiver out of range of transmitter.		Move closer to transmitter.	
Receiver out of range of transmitter.	Defective Handset TS-15- ( ) or headset HS-30- ( ).	Replace.	
	Poor location.	Change locations.	

Table X. Trouble Shooting

Symptom	Probable trouble	Correction
Transmitter dead.	Defective or burned-out tube.	Replace tube. (See par. 104.)
	Misalignment of receiver.	Align receiver. (See par. 116.)
	Power switch turned to OFF.	Turn VOLUME control to the right.
	No phone plug in PHONE No. 1 jack.	Plug phone in PHONE No. 1 jack.
	Defective receiver-transmit switch in handset.	Replace handset.
	Defective handset.	Replace.
	Antenna AN-130-A used without ground connection.	Check ground connection or replace.
	Improper calibration.	Recalibrate. (See par. 26d.)
	Antenna insulator shorted by water or dirt.	Wipe off insulator.
	Antenna touching metallic material or wet foliage.	Keep antenna clear.
Transmitter weak.	Dead or low Battery BA-70 or BA-80.	Replace battery. (See par. 108.)
	Defective or burned-out tube.	Replace. (See par. 104.)
	Misalignment of transmitter.	Realign transmitter. (See par. 116.)
	Improper calibration.	Recalibrate. (See par. 26d.)
	High resistance short across antenna insulator caused by water or dirt.	Wipe off insulator.
	Weak Battery BA-70 or BA-80.	Replace battery. (See par. 108.)
	Weak tube.	Replace tube. (See par. 104.)
	Defective or broken antenna.	Replace.
	Antenna AN-130-A used without ground connection.	Check ground connection or replace.

### 98. Voltage Checks at Metering Socket to Determine Defective Circuit

In this check use a signal generated by the set as a test signal to produce voltages at the metering socket pins. The value of this method of checking depends to a large extent upon the ability of the repairman to interpret results and their causes. Each operation must be carried out accurately and the cause of any variation checked carefully.

*a.* Remove the set from the case and plug it into a fresh Battery BA-70 or BA-80 as shown in figure 72. Cable CD-1108 is a more convenient arrangement for connecting the set to a battery for test purposes.

*b.* Install Phantom Antenna A-28-( ) and plug in Handset TS-15-( ).

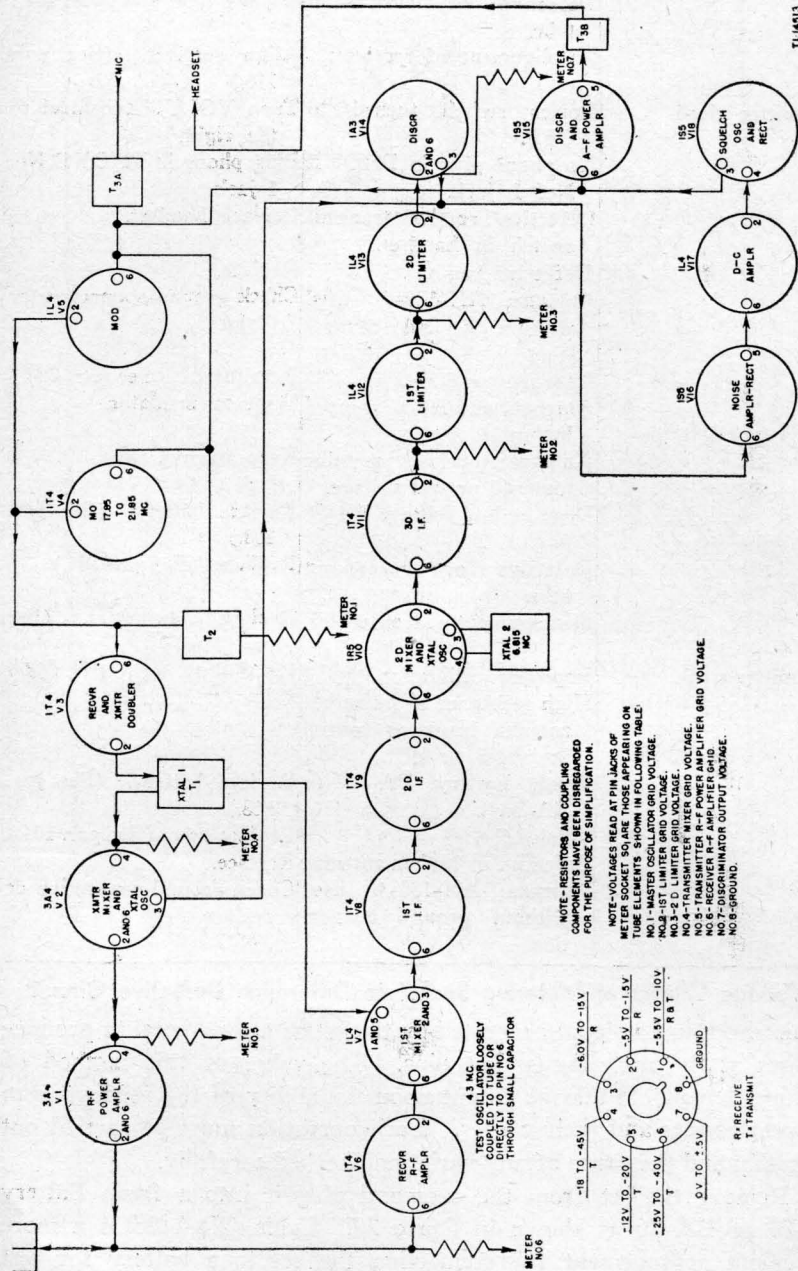

NOTE - RESISTORS AND COUPLING COMPONENTS HAVE BEEN DISREGARDED FOR THE PURPOSE OF SIMPLIFICATION.

NOTE - VOLTAGES READ AT PIN JACKS OF METER SOCKET SO ARE THOSE APPEARING ON TUBE ELEMENTS SHOWN IN FOLLOWING TABLE.

NO. 1 - MASTER OSCILLATOR GRID VOLTAGE.

NO. 2 - 2 D. LIMITER GRID VOLTAGE.

NO. 3 - TRANSMITTER MIXER GRID VOLTAGE.

NO. 4 - RECVR. AND DOUBLER AMPLIFIER GRID VOLTAGE.

NO. 5 - DISCRIMINATOR OUTPUT VOLTAGE.

NO. 6 - GROUND.

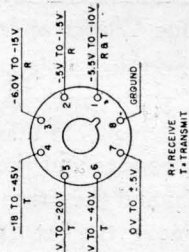

TL4513

Figure 64. Metering socket connections.

c. Turn the VOLUME control to the maximum clockwise position, and the SQUELCH control to the maximum counterclockwise position. A loud rushing noise should be heard in the handset or headset. Tuning from channel 0 to 40.0 should cause neither an increase nor decrease of rushing noise.

d. The following voltages should be present at the metering socket pins (see fig. 64). Little change should be caused by tuning from channel 0 to 40.0 with no carrier signal being received. (Use Alignment Indicator I-210-( ) or an electronic voltmeter for measuring these voltages.)

Pin No.	Voltage(V)	Pin No.	Voltage(V)
1	-4.5 to -10	3	-3.0 to -20
2	0.0 to -1.5	7	-0.5 to + 0.5

e. Turn the SQUELCH control on. The rushing noise in the handset or headset should disappear as the control is advanced clockwise. Turn the SQUELCH control to OFF.

f. Hold down the PRESS FOR DIAL LIGHT & CALIB. button. If the circuit is operating normally, the following conditions should exist:

- (1) Dial light should be dimly illuminated.
- (2) Rushing noise in handset or headset should disappear.
- (3) Zero beat should be obtained at channel 15 and at the check point between channels 36 and 37.

g. Release the PRESS FOR DIAL LIGHT & CALIB. button and press the handset switch. When the operation is normal, the following conditions should exist:

- (1) Rushing noise in handset or headset should disappear.
- (2) Pilot light in phantom antenna should light.
- (3) Zero beat should be obtained at channel 15 and at the check point between channels 36 and 37.

h. Depress the receive-transmit switch, and check the voltages at the metering socket with an electronic voltmeter or Alignment Indicator I-210-( ). The following voltages should be present, and there should be little change noted as the set is tuned from channel 0 to channel 40.

Pin No.	Voltage(V)	Pin No.	Voltage(V)
1	-4.5 to -10	6	-18.0 to -40
4	-18.0 to -45	7	-0.5 to + 0.5
5	-10.0 to -20.0		

i. When the stage which is causing the trouble has been located, use resistance and voltage measurements to determine the circuit element at fault. Information in paragraphs 99 and 100 will be helpful in making resistance and voltage checks.

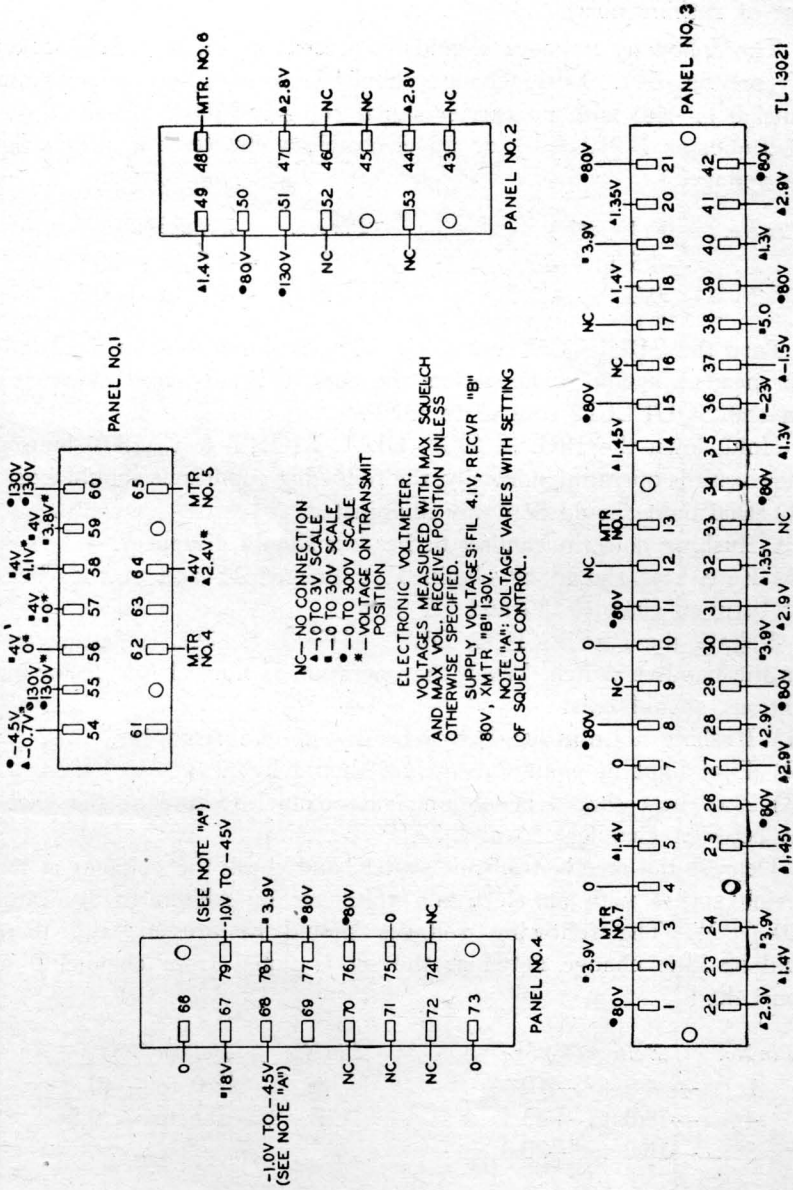
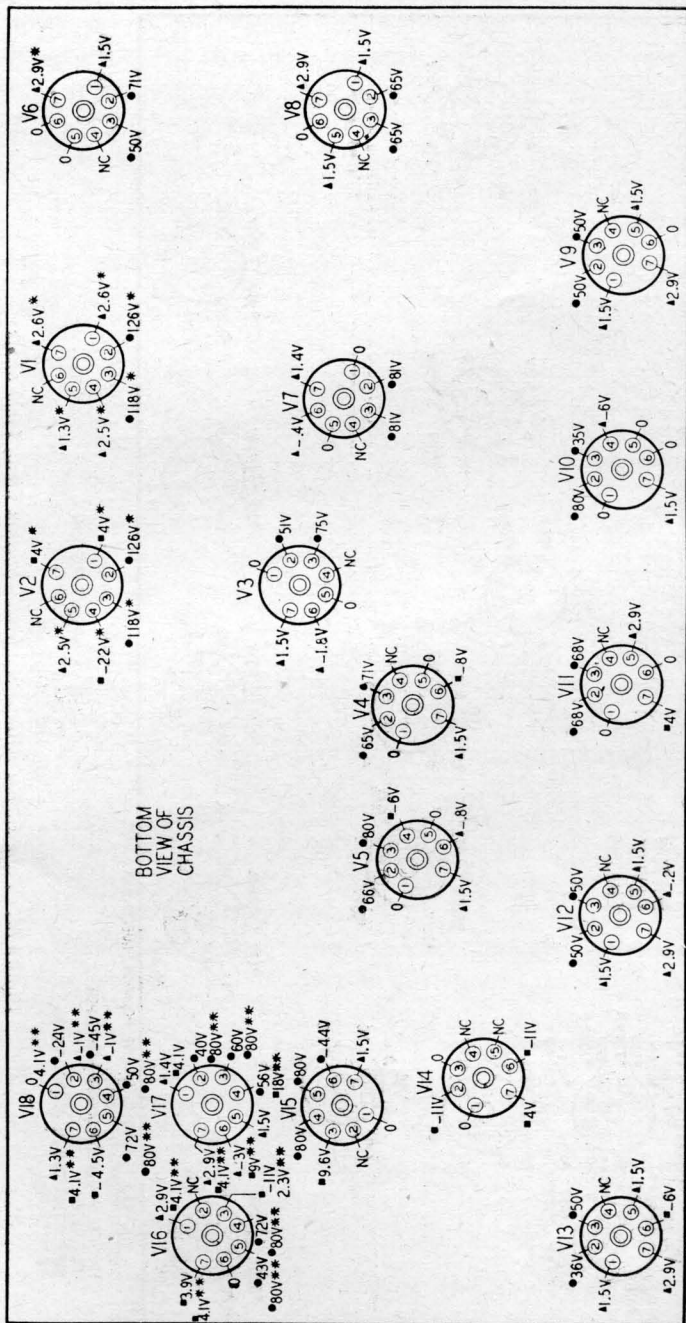

Figure 65. Terminal panel voltage diagram, electronic voltmeter.



NOTE—D-C VOLTAGES TO CHASSIS (RECEIVE POSITION, MAX SQUELCH, AND MAX VOLUME UNLESS OTHERWISE INDICATED).  
 VOLTAGES MEASURED WITH ELECTRONIC VOLTMETER.  
 SUPPLY VOLTAGES: FIL 4.1V, RECVR "B" 80V, XMTR "B" 130V

▲ — 0 TO 3V SCALE  
 ● — 0 TO 30V SCALE  
 ◆ — 0 TO 300V SCALE  
 \* — VOLTAGES ON TRANSMIT POSITION  
 \*\* — VOLTAGES WITH SQUELCH OFF  
 NC — NO CONNECTION

Figure 66. Tube socket voltage diagram—bottom view, electronic voltmeter.



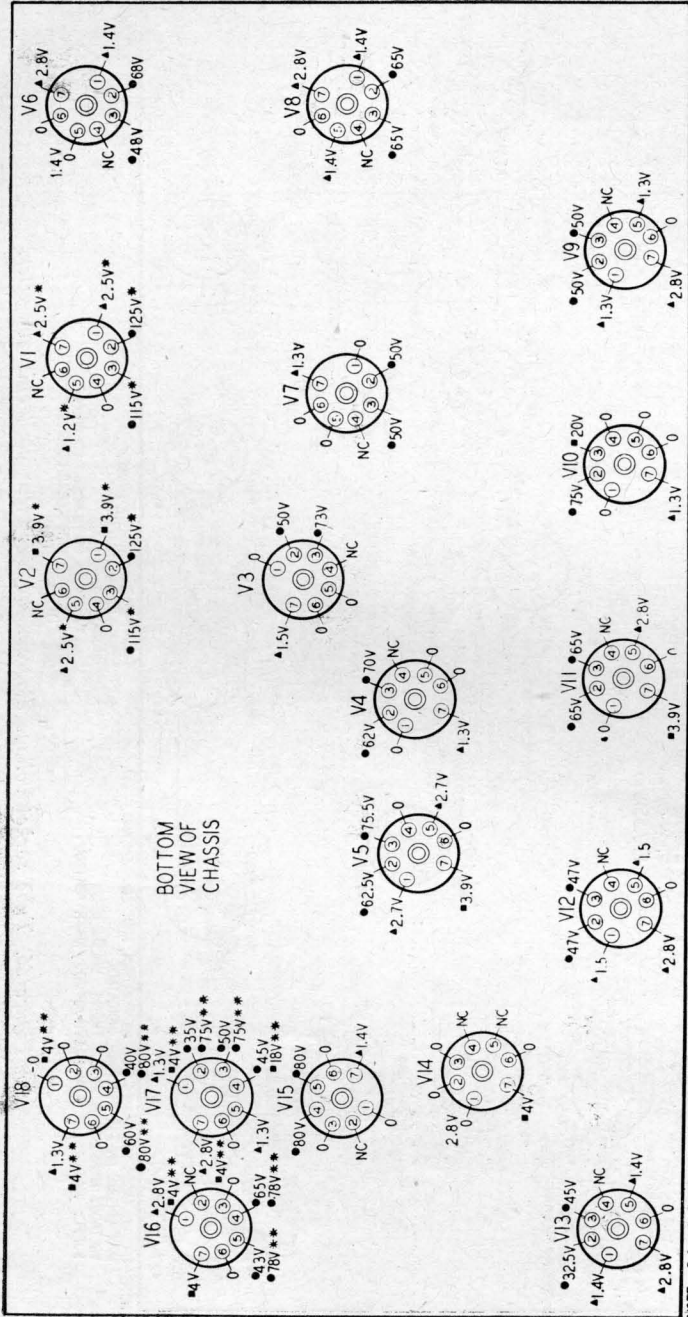

NOTE—DC VOLTAGES TO CHASSIS (RECEIVE POSITION, SQUELCH MAX. UNLESS OTHERWISE INDICATED).

VOLTAGES MEASURED USING 1000 OHMS PER VOLT METER.  
 SUPPLY VOLTAGES FIL 4.5V (RCVR)\*B\* 8.5,  
 XMTR \*B\* 14.5.

- ▲ — 0 TO 3V SCALE
- — 0 TO 30V SCALE
- — 0 TO 300V SCALE
- — VOLTAGE ON TRANSMIT POSITION
- ◆ — VOLTAGE WITH SQUELCH OFF
- NC — NO CONNECTION

TL 13018

Figure 67. Tube socket voltage diagram—bottom view, 1,000 ohms per volt voltmeter.



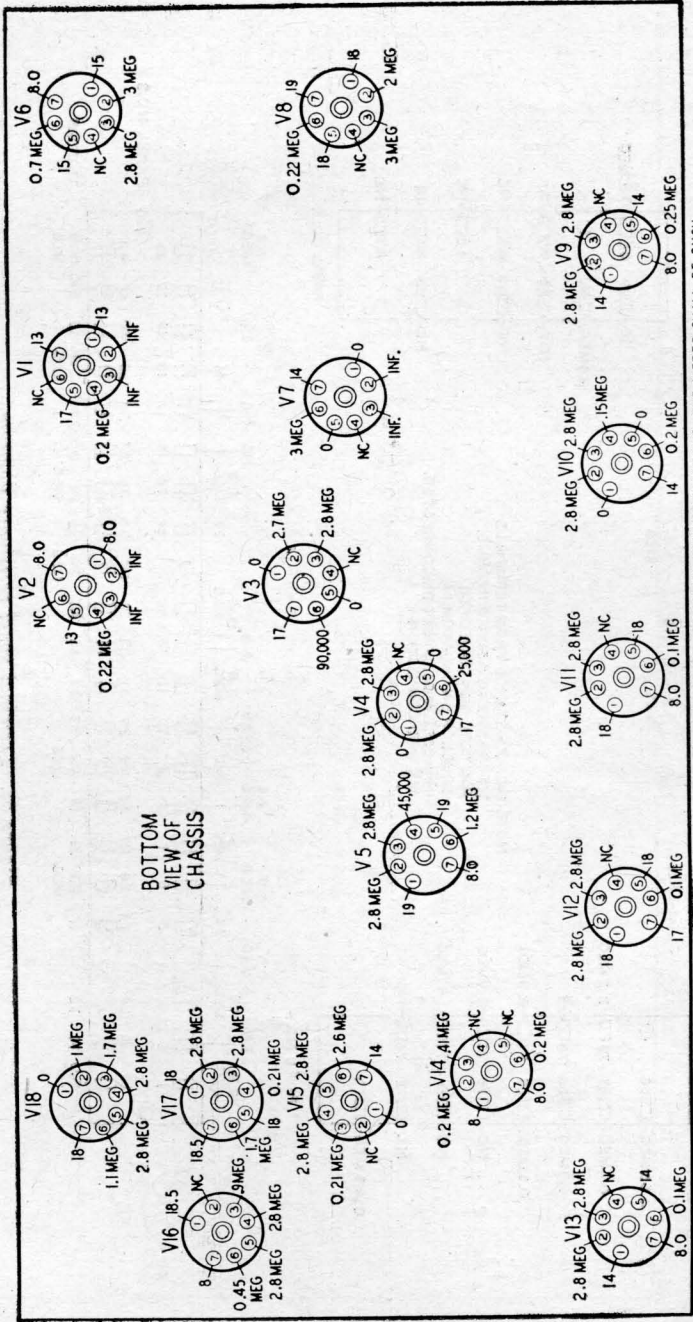

NOTE: DC RESISTANCE TO CHASSIS MEASURED IN OHMS. IN MEASURING RESISTANCE VALUES AT FILAMENT TERMINALS, THE METER SHALL BE SUCH THAT NOT MORE THAN 50 MA. ARE DRAWN WHEN THE LEADS ARE SHOR TED TOGETHER. BATTERY DISCONNECTED.

SQUELCH SWITCH ON (MAXIMUM)  
HANDSET AND HEADSET DISCONNECTED.  
NC—NO CONNECTION  
TUBES IN SOCKET

Figure 69. Tube socket resistance diagram, electronic voltmeter.

TL 13017

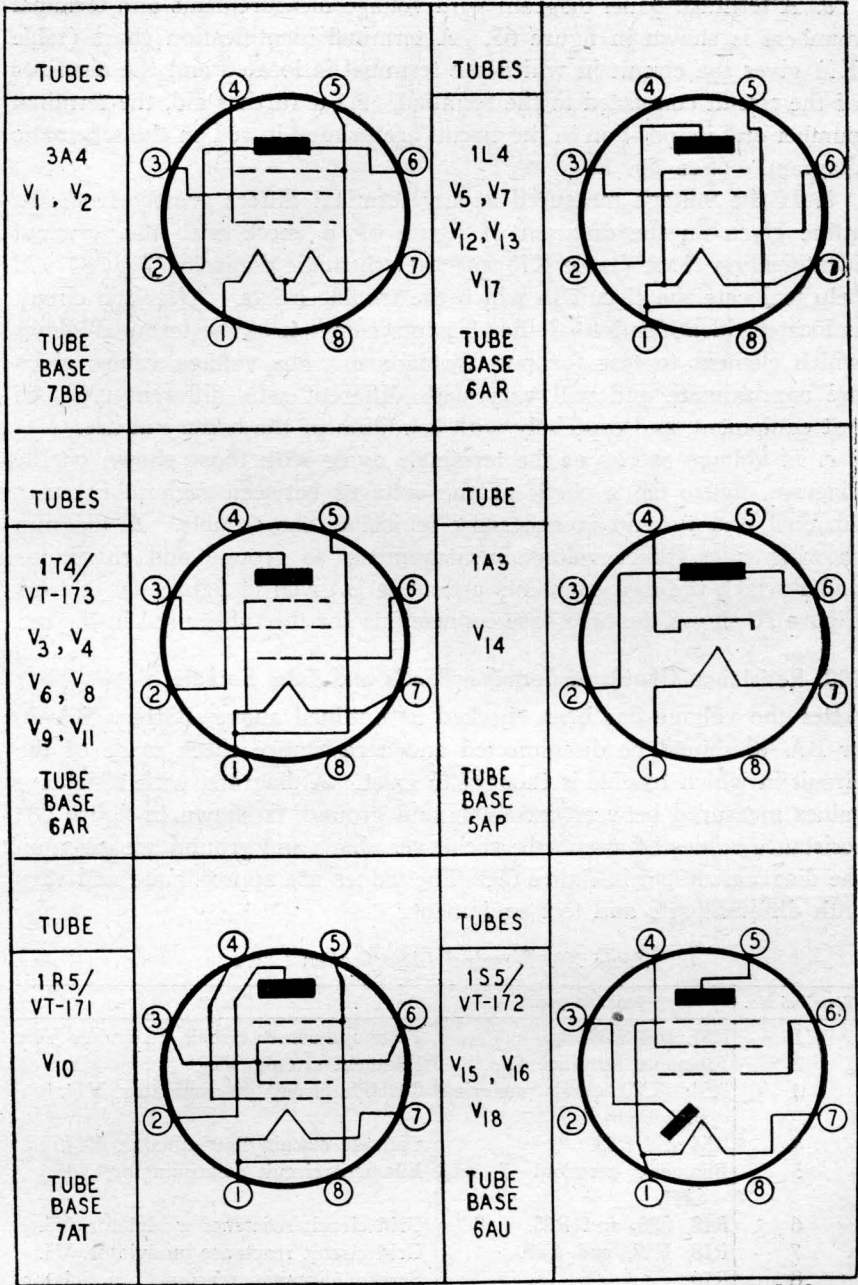

TL 13016

Figure 70. Tube base connections—bottom view.

## 99. Voltage Checks at Terminal Panels and Tube Sockets

a. A terminal panel diagram with voltage measurements and terminal numbers is shown in figure 65. A terminal identification chart (table XI) gives the circuit in which the terminal is located and the elements of the circuit connected to the terminal. As a further aid, the terminal number and its position in the circuit are printed in red on the schematic diagram. (See fig. 88.)

b. If the voltage measured at any terminal differs greatly from the value given on the diagram of figure 65, a check with the terminal identification chart (table XI) and the schematic diagram (fig. 88) will help to locate the circuit in which the trouble exists. After the circuit is located, identification of the elements common to the terminal shows which element to test for possible failure. The voltage values given are approximate and will vary with different sets, different types of test equipment, and especially with condition of the battery in use.

c. If voltage checks at the terminals agree with those shown on the diagram, figure 65, a check of the voltages between each tube socket terminal and ground is necessary to isolate the trouble. A diagram showing tube socket voltage measurements to ground and conditions under which the measurements are made is given in figures 66 and 67. Figure 70 shows the tube base connections for the tubes used in the set.

## 100. Resistance Checks at Terminal Panels and Tube Sockets

After the voltage has been checked as outlined above, Battery BA-70 or BA-80 should be disconnected and a resistance check made of the circuit in which trouble is thought to exist. A diagram, with resistance values measured between terminals and ground, is shown in figure 68; resistance values between tube socket terminals and ground are given on the diagram shown in figure 69. The values are approximate and vary with different sets and test equipment.

Table XI. Terminal Identification Chart

Terminal No.	Junction point	Circuit
1	R47 and R48.	Plate and screen circuit, 2d limiter V13.
2	Filament terminal 7.	Filament circuit, V14.
3	R54, C70, and metering socket pin 7.	Cathode circuit discriminator, V14.
4	R54 and R55.	Cathode circuit discriminator, V14.
5	Filament terminal 7 and CH1.	Filament circuit discriminator, V15.
6	R18, C30, and R55.	Grid circuit reactance modulator, V5.
7	R18, R17, and C29.	Grid circuit reactance modulator, V5.
8	R16.	Screen circuits, reactance modulator, V5.
9	No connection.	
10	C29 and terminal 4 of transformer T3A.	Secondary circuit, T3A.

Table XI. Terminal Identification Chart

Terminal No.	Junction point	Circuit
11	R11, R15, and B+90 v.	Plate supply circuits to V4 and V5, and screen supply, V4.
12	No connection.	
13	R13, C25, and terminal 1 of metering socket.	Master oscillator metering circuit, V4.
14	Filament terminal 7.	Filament circuit, V3.
15	R9, R10, and B+90 v.	Plate and screen circuits, V3.
16	No connection.	
17	No connection.	
18	Filament terminal 7 and CH2.	Filament circuit, V7.
19	Terminal 4 and male battery connector.	Filament supply circuit.
20	Filament terminals 1 and 5, and CH6.	Filament circuit, V8.
21	R29, R27, R25, and B+90 v.	Plate circuit, V6, V7, and screen, V8.
22	Filament terminal 7 and terminals 1 and 5.	Filament circuit, V13 and V14.
23	CH3.	Filament circuit V13 and V7.
24	Filament terminal 7.	Filament circuit, V5.
25	CH8.	Filament circuit, V12.
26	R44 and B+90 v.	Plate circuit, 1st limiter V12.
27	Filament terminal 7 and C71.	Filament circuit, V12.
28	Filament terminal 1 and 5, and C84.	Filament circuit, V5.
29	R41 and B+90 v.	Plate circuit, 3d i-f V11.
30	Filament terminal 7, C86, and 4.5-v filament supply.	Filament circuit, V11.
31	CH9.	Filament circuit, V11 and V12.
32	Filament terminal 7, R76, and CH6.	Filament circuit, V4 and V8.
33	No connection.	
34	R78, R39, and B+90 v.	Screen and plate circuits, V10.
35	Filament terminal 7 and C78.	Filament circuit, V9 and V10.
36	R35 and R70.	Bias voltage filter circuit to power a-f amplifier grid.
37	R77, R35, C48, and R37.	Grid circuit, V10.
38	Prong 5, male battery connecting plug.	Circuit between SW2 and prong 5, male plug.
39	R33, B+90 v, and C52.	Plate circuit, V9.
40	CH4.	Filament circuit, V9 and V10.
41	CH5.	Filament circuit, V9 and V14.
42	R30 and B+90 v.	Plate circuit, V8.
43	No connection.	
44	CH7.	Filament circuit, V5 and V8.
45	No connection.	
46	No connection.	
47	Filament terminal 7.	Filament circuit, V6.
48	R32, C31, R74, and pin No. 6 metering socket.	Metering circuit, V6.

Table XI. Terminal Identification Chart

Terminal No.	Junction point	Circuit
49	Filament terminals 1 and 5, and CH1.	Filament circuit, V6 and V15.
50	R24, R25, and B+90 v.	Screen circuit and plate circuit, V6.
51	R1, prong 7, and male power plug +150 v.	Plate circuit, V1.
52	No connection.	
53	No connection.	
54	Variable tap R51 and C15.	Audio grid circuit, V15.
55	R5 and +150 v.	Screen circuits, V2.
56	R57 and top spring jack J1.	Microphone circuit between R57 and J1.
57	R21 and terminal 2 of T3A.	Primary circuit, T3A.
58	R57, K22, C87, and terminal 5 of V1.	Filament circuit, V1.
59	R21 and top spring PHONE No. 1 jack.	Primary circuit, T3A.
60	R2 and +150 v.	Plate circuit, V1.
61	No connection.	
62	R7, C17, and pin 4 of metering socket.	Metering circuit, V2, grid circuit.
63	No connection.	
64	Pilot light LM1, R56, and PRESS FOR DIAL LIGHT & CALIB. button.	Calibrate switch SW3 and pilot lamp LM1.
65	R3, C8, and pin 5 of metering socket.	Metering circuit for V1.
66	R50 and C28.	Audio coupling circuit.
67	R65 and R66.	Voltage dividing network in SQUELCH control circuit.
68	C68 and R51.	Audio coupling circuit.
69	C90, R59, and pin 6 of tube socket V16.	Grid circuit of noise amplifier and rectifier, V16.
70	No connection.	
71	No connection.	
72	No connection.	
73	C89, R50, R49, C67, and pin 3 of V14.	Cathode circuit discriminator, V14.
74	No connection.	
75	C89, C90, and R58.	High-pass filter circuit to grid circuit of V16.
76	R60, R62, and R65, and B+90 v.	Plate supply, 90 v to SQUELCH noise amplifier V16, screen grid and plate.
77	R73 and center contact J4.	Relay control circuit.
78	Terminal 7.	Filament circuit, V16.
79	R52, R71, and C73.	Bias voltage circuit for a-f power amplifier, V15.

## Section IV. REPAIR

### 101. General

*a.* Only competent personnel supplied with adequate tools and instruments are authorized to service and repair this equipment. An inexperienced operator attempting to make repairs which should be made by a competent repairman may damage the equipment to such an extent that it will have to be sent to a higher echelon for repair.

*b.* The removal and replacement of defective parts or circuit elements in this radio set is very difficult and great care must be taken to avoid further damage to the set or to the new part being installed. Before attempting repairs, make every effort to obtain the proper tools for the job.

*c.* Often it may be necessary to remove other circuit elements to gain access to the defective part. A record should be made of the connections to each element removed and of its position in the set.

*d.* Clip all leads as short as possible and avoid using more solder than necessary to make a secure connection. The slightest amount of solder dropped accidentally inside this set can cause short circuits. Exercise extreme care when soldering. Do not heat lugs or connections more than is absolutely necessary. Excessive heat will damage nearby chokes, capacitors, coil forms, and wiring. When connecting a wire to a tube socket, use a wire long enough to prevent pull on the socket. Before removing a part that appears to be defective, make a thorough electrical check.

**Caution:** Never change the location of parts or wiring leads as undesirable feedback and oscillations may result.

*e.* Exercise extreme care in disassembling and reassembling mechanical units. Secure bolts snugly, but do not overtighten them. Several illustrations are provided to which the repairman can refer when replacing mechanical parts in Radio Receiver and Transmitter BC-1000-A. (See figs. 79, 80, 81, and 82.)

### 102. Handling of Tools

Careful handling of tools is essential in the maintenance of signal equipment. Grasp tools firmly. Do not drop or jar them against breakable parts of the set. A tool dropped on the chassis of Radio Receiver and Transmitter BC-1000-A may damage tubes, resistors, or other delicate components. Do not strain wires, cables, connections, or couplings



unnecessarily. Do not provide space for working on a part by carelessly pushing aside other parts which are in the way.

*a. CARE OF TOOLS.* Work can be performed rapidly and efficiently with well-kept tools. When a job has been completed, wipe the tools with a rag slightly dampened with oil. Occasionally oil the hinge rivets of pliers and similar tools to keep them working freely. Inspect the handles of driving tools to see that they are tight and free from chips and splinters. When tools are to be stored for a long time, cover the surfaces with heavy grease (type GL) as a preservative. Do not use thin oil because its tendency to break down may permit moisture to corrode or rust the metal.

*b. CONSTRUCTION OF SPECIAL MAINTENANCE TOOLS.* The mechanical compactness of Radio Receiver and Transmitter BC-1000-A makes it difficult to solder and unsolder certain parts. To perform soldering operations with ease at close quarters, reshape a standard size soldering iron tip to chisel point as shown in figure 71.

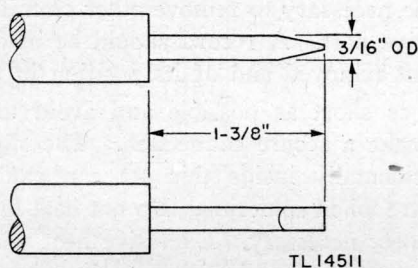

Figure 71. Modified soldering iron tip.

### 103. Painting and Refinishing

*a.* If the finish on the case is badly scarred or damaged, the repairman should touch up the exposed surfaces in order to prevent rust and corrosion. Using #00 or #000 sandpaper, clean the surface down to the bare metal until the finish is bright and smooth. Apply paint with a small brush.

**Caution:** The use of steel wool is not recommended. Although it removes rust rapidly, the small particles of metal which often fall into the case cause internal electrical shorting or grounding of circuits.

*b.* If a complete repainting job is necessary, proceed as follows:

- (1) Remove the chassis from the case.
- (2) Loosen rust and corrosion with dry-cleaning solvent.
- (3) Using #00 or #000 sandpaper, clean the surface down to the bare metal until the finish is bright and smooth.

(4) Spray-paint the entire case using a paint which is authorized by existing regulations.

#### 104. Tube Checking and Replacement

a. Loosen Radio Receiver and Transmitter BC-1000-A in the chassis case by unfastening the six upper clip-catch fasteners. Then the chassis can be lifted out of the case.

b. While the set is out of the case, supply power by plugging the chassis directly into the battery receptacle, as shown in figure 72.

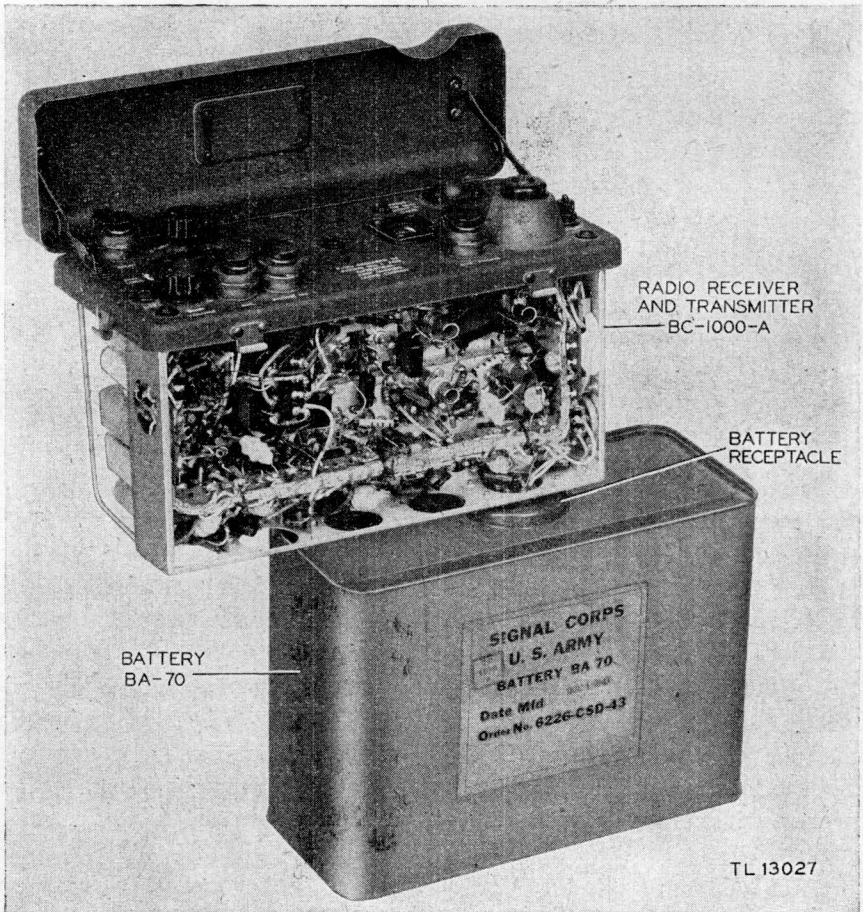

Figure 72. Radio Receiver and Transmitter BC-1000-A, connected directly to Battery BA-70 for test purposes.

c. Burned-out tubes can be located by following the instructions in table XII. *It is not necessary, nor is it recommended* that any but the defective tubes be replaced. If the trouble is not caused by a burned-out

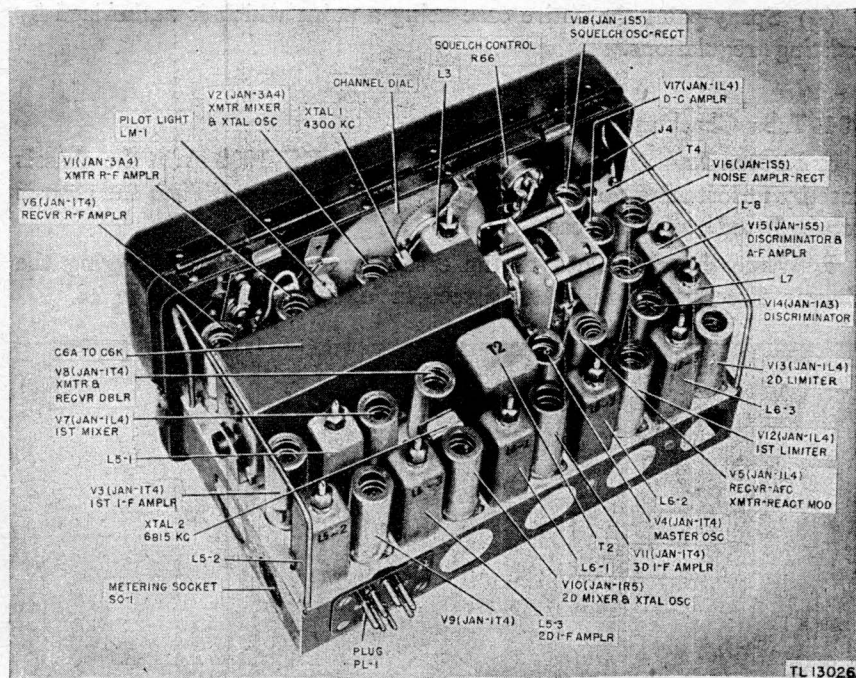

Figure 73. Radio Receiver and Transmitter BC-1000-A—chassis top, rear view.

or broken tube, as indicated by the tests in the chart, do not attempt further analysis unless complete test equipment is available. When replacing tubes, be certain to use correct replacements. Check this by reading the type number of the tube removed from the socket, and also by comparing the new tube with the tube number stamped on the chassis. The tube lay-out is shown in figure 73.

To remove a tube shield, press down on the shield, twist it slightly to the left, and lift it off. To replace a tube shield, place the shield over the tube, line up the slots, press the tube shield down, and twist it to the right to lock it in place. The tube shields *must* be replaced because they prevent interaction between circuits and help retain the tubes in their sockets.

### 105. Voltage Checks at Metering Socket

**Caution:** Never press the press for dial light & calib. button and the receive-transmit switch at the same time; doing so places excessive voltage on the filaments of the transmitter mixer tube V2.

Alignment Indicator I-210-( ) or an electronic voltmeter connected between the chassis and the metering socket pin jack terminals can be

used for voltage indication. Failure to perform tests in proper order will give erroneous results. Perform each test, and if no voltage is indicated, replace the tube listed for that particular test. (See table XII.) If changing tubes does not give a normal voltage reading, the defect is not caused by tube failure, and an analysis with test equipment is necessary.

Table XII. Burned-out tube location chart

Test No.	Following tube filaments OK if indication is obtained	Metering socket connection	Operation	OK if
1	V4, V5, and V8.	1		Voltage indication is present on 6-volt scale.
2	V2 (also dial lamp).	4	Press PRESS FOR DIAL LIGHT & CALIB. button.	Dial lamp lights dimly. Voltage indication is present on 30-volt scale.
3	V1.	5	Press receive-transmit switch.	Voltage indication is present on 30-volt scale.
4	V11, V12, and V3.	5	Press receive-transmit switch.	Voltage indication is present on 30-volt scale.
5	V9, V10, and V14.	2	Press PRESS FOR DIAL LIGHT & CALIB. button.	Voltage indication is present on 30-volt scale.
6	V7 and V13.	3	Press PRESS FOR DIAL LIGHT & CALIB. button.	Voltage indication is present on 30-volt scale.
7	V6 and V15.	—	Press PRESS FOR DIAL LIGHT & CALIB. button.	Signal is heard at either one of the calibration marks.
8	V16, V17, and V18.	—	Turn SQUELCH control on and advance to the right.	Noise disappears.

If any tubes listed in table XII are changed, realign the set in accordance with the instructions in table XIII. Perform only the alignment adjustment corresponding to the tube changed.

Table XIII. Realignment table, after tube replacement

Tube changed	Adjustment to be made	Indicator used	Connect indicator to	Adjust for	Dial setting	Press the following
V1	C6A	Antenna A-28 (Phantom). or: Alignment Indicator I-210-( ), 30-volt range (with either short or long antenna installed in set).	Antenna terminal.  Pin No. 6 of metering socket.	Maximum brilliance of bulb.  Maximum dark area.	Channel 35 (check over complete range).	Receive-transmit switch.
V2	C6C C6E	I-210-( ), 30-volt range.	Pin No. 5 of metering socket.	Maximum dark area.	Channel 35 (check over complete range).	Transmit switch.
V3	C6E  C6G	I-210-( ), 30-volt range.  Headset.	Pin No. 5 of metering socket.  PHONE No. 1 jack.	Maximum dark area.  Zero beat.	Channel 35 (check over complete range).  Calibration mark, either at channel 15 or between 36 and 37. (Indicator must be centered on window before setting dial to calibration mark).	Transmit switch.  PRESS FOR DIAL LIGHT & CALIB. button.
V4  V5	C6G	Headset.	PHONE No. 1 jack.	Zero beat.	Calibration mark, either at channel 15 or between 36 and 37. (Indicator must be centered in channel window before setting dial.)	PRESS FOR DIAL LIGHT & CALIB. button.
V14 or V15	L8	I-210-( ), 4.5-volt range. Adjusted to close at 0 volt.	Pin No. 7 in metering socket.	0 volt.		PRESS FOR DIAL LIGHT & CALIB. button.

### 106. Testing Tubes with Test Set I-56-( )

When using Test Set I-56-( ), consult the following Technical Manuals for tube testing information:

Test Set I-56-E .....	TM 11-321
Test Sets I-56-C, I-56-D, I-56-H, and I-56-J.....	TM 11-303
Tube Tester I-177 .....	TM 11-2627

### 107. Dial Lamp Replacement

a. Remove Radio Receiver and Transmitter BC-1000-A chassis from the chassis case.

b. Remove the dial lamp socket and bulb from the dial lamp bracket. The socket is removed from the dial lamp bracket by pulling it straight up.

c. Remove the defective bulb and replace it with a Mazda No. 47 bulb, 6-8 volts, 0.15-ampere, bayonet base. The bulb is held in the socket by means of pins which engage bayonet slots in the socket. To remove, push bulb into the socket and turn to the left. To replace, push the bulb into the socket and turn to the right to lock in place.

d. Replace the dial lamp socket, with the bulb included, on the dial lamp bracket.

### 108. Battery Checking and Replacement

a. BATTERY CHECKING. Check the battery with a voltmeter and shunt load resistor. Each section of the three-section battery is checked separately using the information in table XIV. The voltmeter and shunt resistor are held across the proper terminals as shown in figure 74 for 15 seconds. Do not test for a longer period.

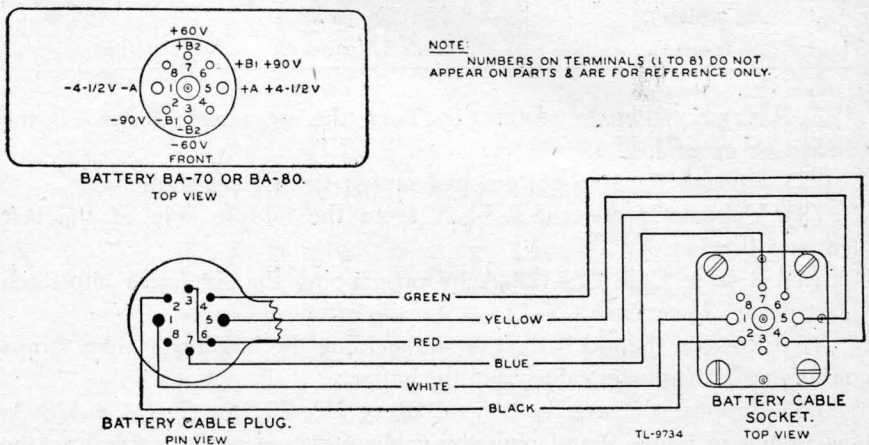

Figure 74. Battery BA-70—top view, and battery wiring diagram.

If the reading falls below the end-point voltage (value below which the battery and radio set do not operate efficiently) replace the battery immediately. Voltages under load when the battery is new, the value of the load resistors, and end-point voltages are shown in table XIV.

Table XIV. Battery voltages under load

Normal	Load resistor	End point
4.35 (filament)	8 ohms, 5 w	3.6
84 (plate)	1,100 ohms, 5 w	66
54 (plate)	860 ohms, 5w	44

If load resistors of the size specified above are not available, and cannot be made up by using series parallel combinations of resistors, use the following procedure to check condition of the battery:

(1) Obtain a Radio Receiver and Transmitter BC-1000-A which is known to be in proper operating condition.

(2) Remove the Radio Receiver and Transmitter BC-1000-A and the battery from their cases and interconnect them with the battery cable assembly from Maintenance Equipment ME-40- ( ).

(3) Connect Handset TS-15- ( ) and phantom Antenna A-28- ( ).

(4) Turn on set.

(5) Measure voltages between the chassis and terminals as indicated in table XV. See figure 75 for a view of the terminal panels. Replace the battery if any one of the following end-point voltages is indicated:

Table XV. Battery voltages at terminal panels

New	Terminals	End point
4.5 (filament)	No. 59, panel 1	3.6
150 (plate)	No. 60, panel 1	110
84 (plate)	No. 1, panel 3	66

b. BATTERY REPLACEMENT. (1) Turn the set upside down on the bench or ground.

(2) Unsnap the two bottom pad straps from Pad M-391-A.

(3) Unhook Harness ST-54-A from the middle hole of the belt carrier bracket.

(4) Release Case CS-128-A by unsnapping the six lower clip-catch fasteners. Then Case CS-128-A can be lifted off.

(5) Remove the old battery by unbuckling the battery retainer straps and remove the power cable from the battery.

(6) Support the new battery (Battery BA-70) on Case CS-128-A, as shown in figure 9 and plug the rubber-covered power cable into the battery socket.

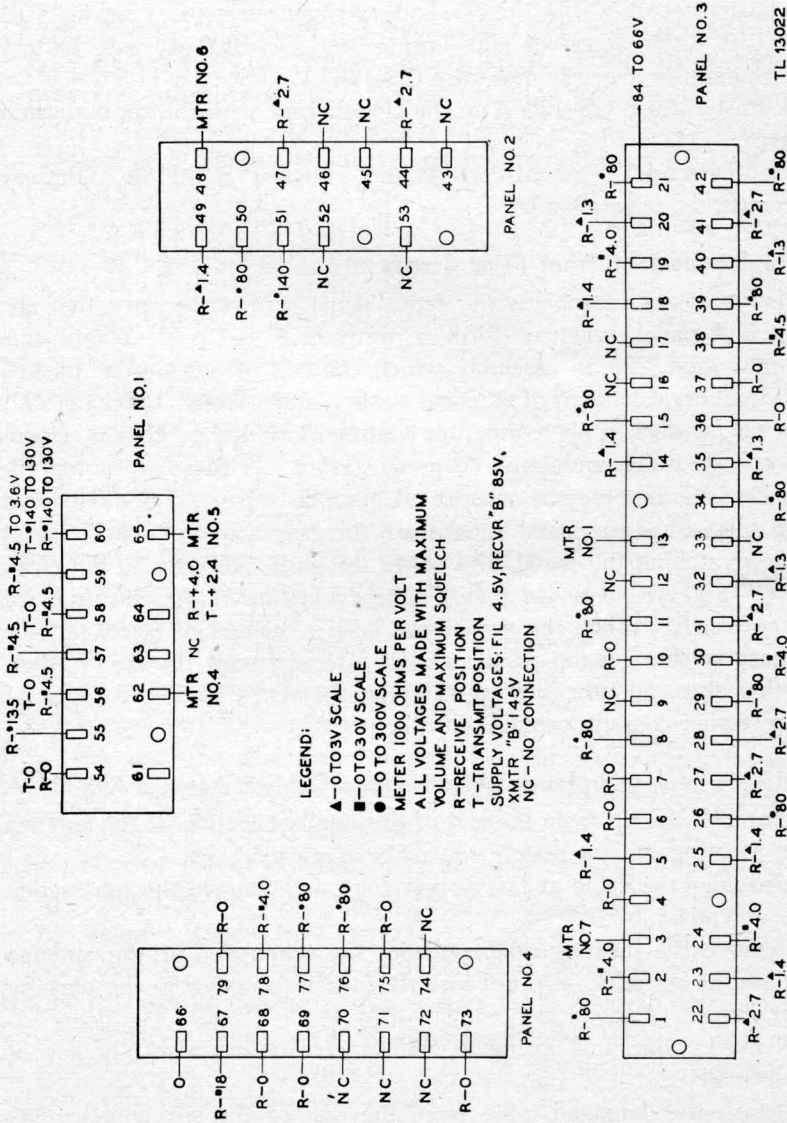

Figure 75. Terminal panels 1 and 3 showing terminals used in checking batteries.



(7) Lift the battery with the power cable attached, and gently lay it upside down on the bottom of the inverted chassis case. The battery cable must lie between the battery and the chassis case in one large loop. The battery must be centered and aligned with the chassis case. Care must be taken to avoid damage to the flange and gasket of the chassis case. Fasten securely with the two battery retainer straps. (See fig. 10.)

(8) Lift Radio Receiver and Transmitter BC-1000-A, with battery attached, and lower gently into Case CS-128-A. (See fig. 11.)

(9) Fasten Case CS-128-A to the chassis case with the six clip-catch fasteners.

(10) Reassemble Pad M-391-A and Harness ST-54-A. Battery replacement is now completed.

### 109. Replacement of Front Panel Screws

If it is necessary to replace the front panel screws, be sure that the screws and panel juncture form a watertight seal. To obtain this watertight joint, use an assembly which consists of a neoprene gasket, a brass washer, a shakeproof external washer, and a screw. (See fig. 79.) Whenever possible, apply a generous coating of rubber or glyptal cement to the crackle finish under the neoprene gasket. If these are not available, a heavy grease may be substituted. As a last resort, if none of these is available, scrape the metal underneath the gasket free of crackle paint without scratching the metal, and apply the gasket directly to the clean metal. *The neoprene gasket should never be applied to the crackle finish surface directly.* When the gasket has been cemented in place, put the thin brass washer on top of the gasket. Now mount the cup washer, the lockwasher, and the screw. Tighten the screw until the edges of the cup washer come in contact with the panel.

### 110. How to Replace Broken or Defective Steel Cable in Antenna AN-131-A

a. Unscrew the tip from the end of the smallest section of the antenna (top). Heating with a match will make removal easier.

b. Unsolder the cable at this point (top) and remove the top section of the antenna.

c. Remove the bushing adapter from the other end of the antenna (large end at bottom). Do not lose the star lockwasher in the bushing adapter cup.

d. Remove cable and spring assembly after noting carefully how it was assembled.

e. Detach the damaged cable from the rest of the spring assembly. If the cable is broken, remove broken sections.

f. Clean all antenna sections and spring assembly parts. Remove grease and sand particles.

g. Tie a knot at one end of the replacement cable and apply solder to keep the knot from slipping.

*h.* Thread the other, or unknotted end, through the small brass cup at the base end of the antenna. Make certain that the concave end of the cup faces away from the knot.

*i.* Thread the antenna spring stop (small steel tube) onto the cable.

*j.* Thread the antenna compression spring on the end of the cable. It must go over the antenna spring stop and fit into the concave portion of the brass cap.

*k.* Thread the small brass washer into the cable.

*l.* Thread the bottom or largest antenna section into the cable, screw-threaded end first.

*m.* Pull the spring assembly into the antenna section. Be certain that the spring is in the concave section of the brass cup.

*n.* Thread the remaining antenna sections into the cable in order of size (that is, largest sections first.) Be certain that the male end of each section always goes in first.

*o.* Assemble the various sections and firmly hold the unknotted end of the steel cable.

*p.* Pull the unknotted section of the cable until the spring has been fully compressed. Measure a point *exactly* 9 inches from the top tip of the antenna with the spring still fully compressed and make a mark on the cable at this point. Be sure to allow exactly 9 inches, or it will be impossible to fold the antenna.

*q.* Solder the cable at the point marked into the small hollow tip end of the antenna (top).

*r.* Place the small tip or cap over the soldered end, and screw tightly.

*s.* Replace the bushing adapter at the base or bottom end of the antenna. Be sure that the lockwasher is in the bottom of the adapter. Screw on the adapter and tighten it with a pair of pliers to make sure that it will not work loose.

### III. Replacement of Oscillator Coil T2

*a.* Remove the chassis from the case.

*b.* Turn the chassis bottom side up on the workbench. Improvise an arrangement to prevent slug adjustment screws on the i-f coils from being damaged.

*c.* Carefully remove all parts and wires connected to the bottom of the coil. Make a drawing showing parts and wire locations.

*d.* Remove the four nuts and lockwashers holding coil T2 and its shield in place.

*e.* Remove the coil and shield from the set.

*f.* Install the new coil. Two of the lockwashers and **nuts will hold** the new coil in place.

*g.* Replace the coil shield and secure it with the **remaining** two lock-nuts and washers.

*h.* Replace all circuit elements in their original positions and carefully solder them in place.

*i.* With the headset plugged into PHONE No. 1 jack and SQUELCH control turned to OFF, apply battery voltage by turning the set on with the VOLUME control knob.

*j.* Adjust the indicator line to the center of the CHANNEL window.

*k.* Set the calibration mark on the dial, between channels 36 and 37, directly under the indicator line.

*l.* Press the PRESS FOR DIAL LIGHT & CALIB. button and adjust trimmer C6G (fig. 86) for zero beat in the headset.

*m.* Set the tuning dial at calibration mark C, channel 15. Zero beat should occur at this point, as indicated by indicator line in CHANNEL window. If, however, the indicator line is below the calibration mark, the circuit inductance must be increased. If the indicator line is above the proper position, decrease the circuit inductance.

*n.* Increasing or decreasing the inductance is accomplished by lengthening or shortening the connection between capacitor C6G and the oscillator coil. The lead from trimmer C6G is connected to this wire. The point at which the connection is made will determine the value of the oscillator circuit inductance. Variation of the inductance is accomplished by moving the connecting point away from or closer to the tube socket.

*o.* In brief, the inductance should be varied so that when trimmer C6G is adjusted, mark C between channels 36 and 37, and also at channel 15, will appear directly under the CHANNEL window indicator line at zero beat.

## 112. Replacement of Radio-Frequency Coils L1, L2, L4, and Transformer T1 (fig. 86).

*a.* Carefully remove the set from the case.

*b.* Make a chart of all circuit elements and wires connected to the coil which is to be removed. Show the position of the coil, the position and length of all connecting wires, and the position and connections of all circuit elements connected to the coil.

*c.* Remove all circuit elements and wires connected to the coil.

*d.* Remove the coil by removing the two screws holding it to the chassis.

*e.* Fasten the new coil form by means of the two screws which held the damaged coil in place.

*f.* Replace all wires and circuit elements. Use as little solder as possible and make a neat electrical connection. Do not hold the soldering iron on any lug too long, or the coil circuit element may be damaged.

*g.* The set should be aligned according to the instructions given in paragraph 116, 117, or 118.

*h.* Turn the CHANNEL dial to channel 4.

*i.* To determine whether the inductance of the coil should be increased (turns moved closer together), or decreased (turns moved farther apart), vary the trimmer capacitor shunting the replaced coil but do not move any other trimmer. (See table XVI.)

Table XVI.—Coil inductance adjustments

For coil	Use trimmer	Metering socket pin jack used for test	Condition
L1	C6A	No. 6	Transmit
L2	C6C	No. 5	Transmit
L4	C6K	No. 2	Receive (no signal)
T1	C6E	No. 5	Transmit

*j.* Before varying a trimmer, first mark the position of the rotor. Now adjust the trimmer for maximum deflection on the electronic voltmeter. If the trimmer capacitance has to be increased, more inductance is required for proper tracking; if the trimmer capacitance has to be decreased, less inductance is required.

*k.* Coil inductance is increased by moving the top turn of the coil closer to the other turns. To decrease inductance move the top turn away from the others.

*l.* Turn the dial back to channel 35 and adjust for maximum reading by varying the trimmer capacitor.

*m.* Continue adjusting the coil inductance for maximum meter indication on channel 4 and vary, if necessary, the trimmer for maximum reading on channel 35 until tracking is obtained. If the set is tracking, there will be little or no change in indication on the electronic voltmeter over the entire frequency range of the dial.

*n.* After the correct position of the top turn has been attained, cement it to the coil form.

### 113. Replacement of Crystals

**Caution:** Crystal replacements should be made only if the crystal is known to be bad.

*a.* 6.815-MEGACYCLE CRYSTAL. If the 6,815-kc crystal (XTAL 2) is replaced, it will be necessary to realign the discriminator. For alignment instructions, see paragraph 116.

*b.* 4.3-MEGACYCLE CRYSTAL. If the 4,300-kc crystal (XTAL 1) is replaced, the accuracy of the set may be impaired because the calibration points at channel 15 and between channels 36 and 37 are hand calibrated to the harmonics of the crystal originally issued with the set. The error caused by changing this crystal, however, will not seriously impair the normal use of the set. For adjustment of the 4.3-mc crystal oscillator, see paragraph 116*b*.

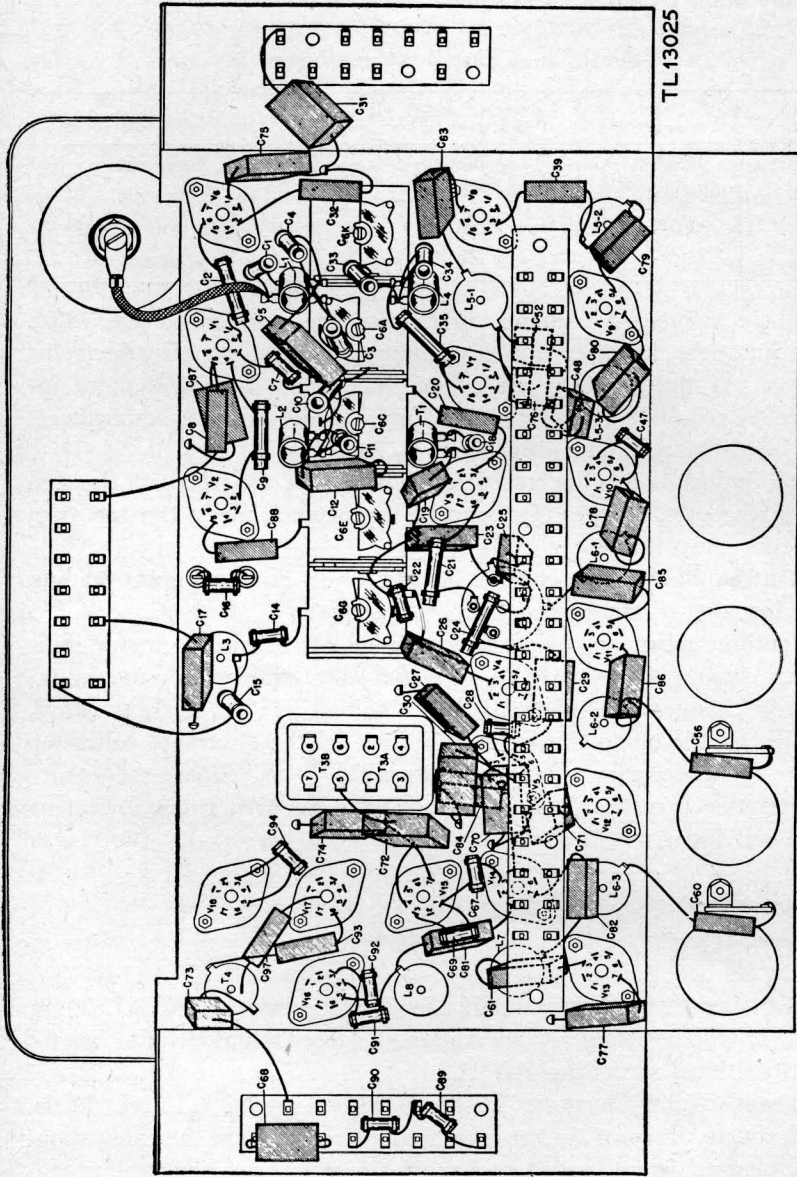

Figure 76. Radio Receiver and Transmitter BC-1000-A—pictorial wiring diagram, showing location of capacitors.

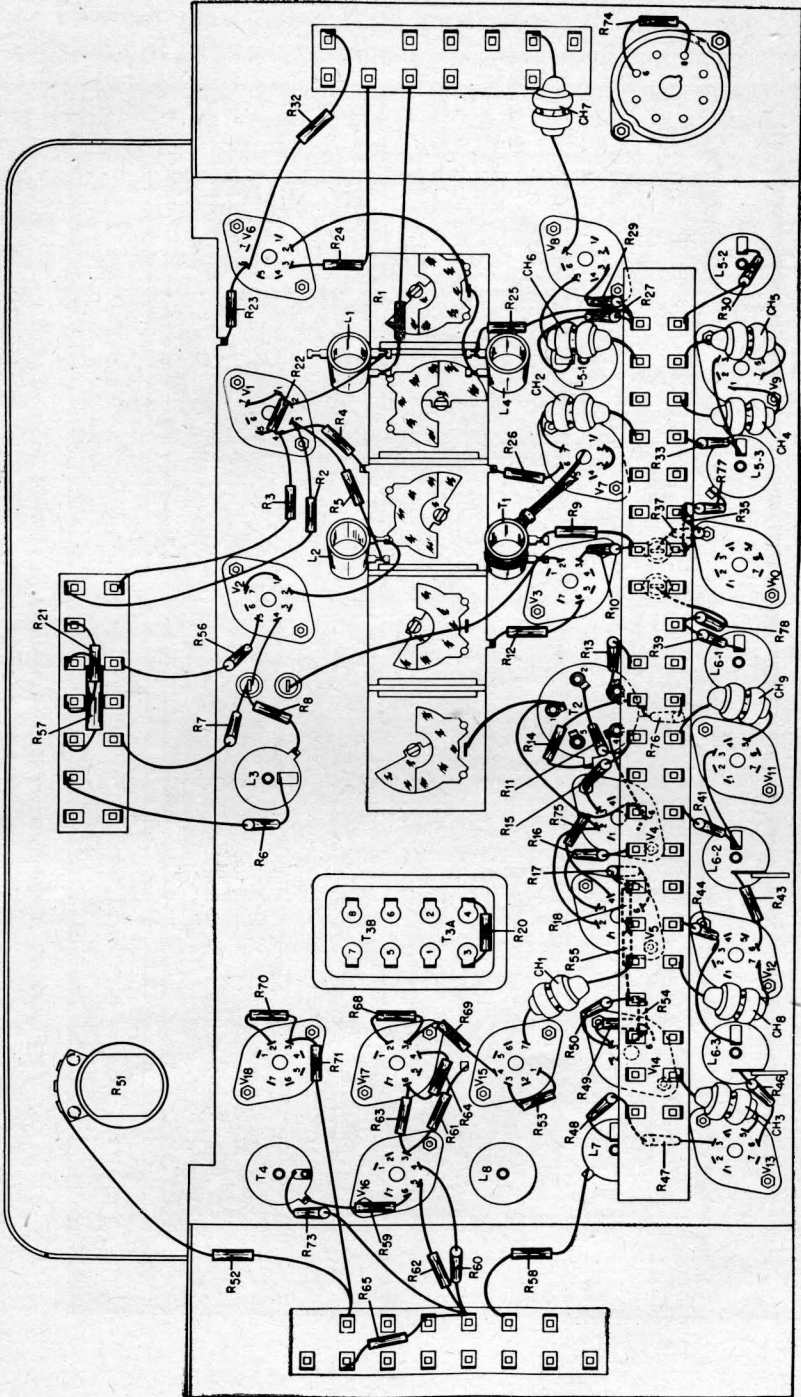

Figure 77. Radio Receiver and Transmitter BC-1000-A—pictorial wiring diagram, showing location of resistors and chokes.

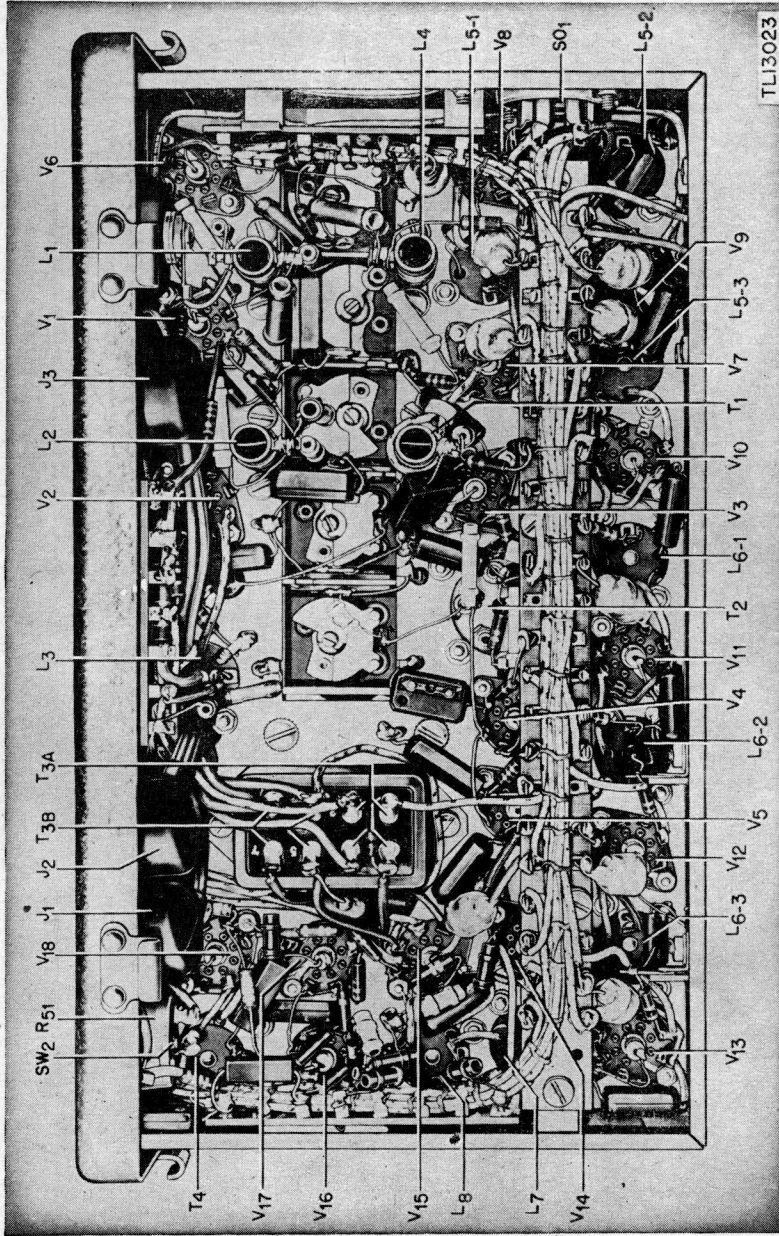

Figure 78. Radio Receiver and Transmitter BC-1000-A, location of major parts—bottom view.

#### 114. Replacement of Miscellaneous Parts

*a. FRONT PANEL.* When parts are removed from the front panel, replacement of lockwashers, cupwashers, washer springs, and waterseal washers in the proper order is important to protect the waterproofing of the set. Details of reassembling the proper washers with antibacklash assembly mounting screws, dial lamp bracket mounting screws, and cap screws holding the front panel to the chassis are shown in figure 79. This figure includes a sectional view of the front panel, showing dial mechanism parts.

*b. VOLUME AND SQUELCH Controls.* Waterseal washers must be fitted snugly when jacks, VOLUME, or SQUELCH controls are replaced. (See fig. 80.) VOLUME and SQUELCH control knobs each have two setscrews to prevent slipping on the shaft. Both should be tightened. In resoldering connections to controls, leads should be kept short and soldered securely with a minimum of heat.

*c. CHASSIS CASE.* Assembly details of screws and washers used on the chassis case are shown in top and bottom views of figure 81.

*d. ANTENNA INSULATOR AND CALIBRATION SWITCH.* The antenna insulator consists of a mounting bolt and pin assembly bushing, top and bottom insulator, and fastening bolt together with waterseals and insulator gaskets. (See fig. 82.) A waterproof cover protects the PRESS FOR DIAL LIGHT & CALIB. switch. (See fig. 79.)





<i>Reference No.</i>	<i>Description</i>	<i>Description</i>
102	Antibacklash assembly.	
108	Dial gear bushing.	
109	Cap screw holds front panel to chassis.	
112	Clip for clip-catch fasteners.	
113	Panel cover.	
114	Dial and pinion assembly.	
115	Waterproof cover over PRESS FOR DIAL LIGHT & CALIB. switch.	
116	Indicator escutcheon plate.	
117	Flange for waterproof cover 115.	
119	Jack waterseal plunger gasket.	
120	Indicator window waterseal gaskets.	
121	Waterseal gasket between Radio Receiver and Transmitter BC-1000-A and chassis case.	
123	Antenna AN-130-A ground terminal. Also holds front panel to chassis.	
124	Panel cover hinge.	
125	Top insulator of antenna insulator assembly.	
127	Dial indicator pointer.	
128	Adjustable indicator frame and dial indicator pointer.	
129	External jack waterseals.	
130	Dial indicator adjustment knob.	
131	SQUELCH and VOLUME control knobs.	
136	Lockwasher for No. 6 screw.	
144	Nut for No. 6 screw.	
145	Dial indicator adjustment packing nut.	
146	Tuning and pinion shaft packing nut.	
148	Jack waterseal plunger.	
150	Indicator window escutcheon mounting screw.	
151	Diaphragm flange mounting screw.	
155	Dial light bracket mounting screw.	
156	Indicator adjustment knob fastening screw.	
157	Antibacklash assembly mounting screw.	
159	Mounting screw front panel to chassis.	
160	Dial gear bushing mounting screw.	
161	Spinner knob setscrew.	
162	Setscrew, locks dial gear mounting screw	
164	Tuning and dial drive shaft.	
169	Tuning knob.	
170	Dial lock assembly.	
171	Jack waterseal gasket retainer.	
173	Front cover support.	
180	Lockwasher antibacklash mounting screw and dial light bracket mounting screw.	
181	Lockwasher under binderhead screws that lock front panel to chassis.	
182	Washer under dial gear bushing.	
183	Washer under antenna fastening bolt head.	
184	Lockwasher under head of panel mounting cap screw, and ground terminal stud and nut assembly.	
185	Washer under heads of waterseal diaphragm and indicator window escutcheon mounting screws.	
187	Friction washer for indicator adjustment knob.	
188	Packing washer for tuning and pinion shaft waterseal.	
189	Packing washer for indicator adjustment knob, waterseal.	
190	Spring washer for indicator adjustment knob.	
191	Waterseal washer for antibacklash mounting screw and dial light bracket mounting screw.	
192	Waterseal washer under binderhead screws that mount panel to chassis.	
193	Dial gear bushing waterseal washer.	
194	Waterseal washer for antenna fastening bolt, front panel mounting cap screws, and ground terminal stud and nut assembly.	
198	Dial indicator window.	
202	Cup washer provides waterseal control.	
203	Antifriction washer.	
204	Antifriction washer.	
205	Cup washer provides waterseal control.	
207	Cup washer provides waterseal control.	
208	Antifriction washer.	
209	Lockwasher under dial gear bushing mounting screw.	

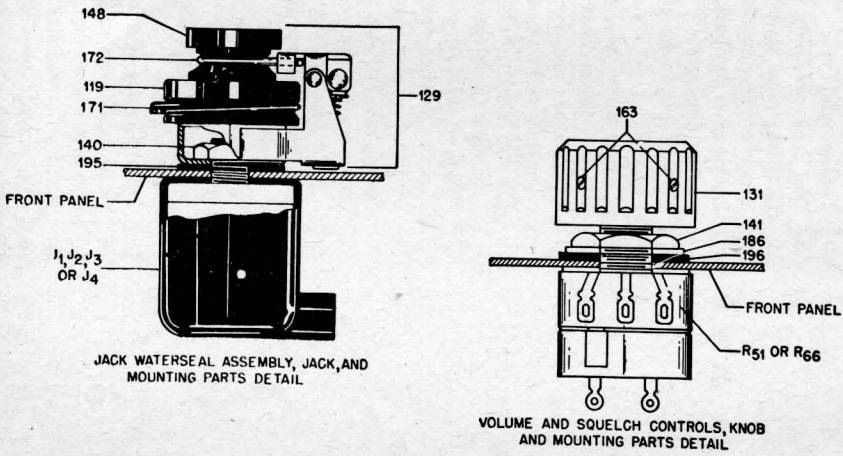

TL12432

Figure 80. Radio Receiver and Transmitter BC-1000-A—parts location detail, showing jack waterseal assembly, VOLUME and SQUELCH controls.

<i>Reference No.</i>	<i>Description</i>
J1	MIC. jack.
J2	PHONE No. 1 jack and filament control.
J3	AUX. phone jack.
J4	RELAY jack.
R51	VOLUME control.
R66	SQUELCH control.
119	Jack waterseal plunger gasket.
129	Jack waterseal assembly.
131	SQUELCH and VOLUME control knobs.
140	Jack and jack waterseal assembly mounting nuts; calibration switch mounting nut.
141	Mounting nuts for SQUELCH and VOLUME controls.
148	Jack waterseal plunger.
163	VOLUME and SQUELCH control knob setscrews.
171	Jack waterseal gasket retainer.
172	Plunger retainer spring.
186	Washer used under SQUELCH and VOLUME control mounting nut.
195	Waterseal washer between jack waterseal assembly and front panel.
196	SQUELCH and VOLUME control mounting nut waterseal washers.



<i>Reference No.</i>	<i>Description</i>
118	Antenna insulator gasket.
126	Bottom insulator of antenna insulator assembly.
204	Antifriction washer.
301	Complete battery cable assembly.
302	Battery cable and plug.
303	"D" ring retainer bracket.
304	Snap bracket.
306	Clip for clip-catch fasteners.
307	Strap retainer "D" ring.
308	Battery strap gasket.
309	Clip gasket.
310	"D" ring retainer bracket gasket.
311	Panel and housing gasket.
312	Socket gasket.
313	Lockwasher used with No. 6 screw.
314	Nut for fastening battery cable to chassis case.
315	Nut for screw No. 321.
316	Battery strap plate.
317	Socket housing plate.
318	Rivet holds down clip mounting; snap bracket mounting.
319	Screws fastening battery retainer straps to chassis case.
321	Screw mounts hold down clip-catch fasteners and "D" retainer brackets.
322	Battery cable socket.
323	Battery retainer strap and buckle.
324	Long battery retainer strap.
325	Short battery retainer strap.
326	Washer.
327	Washer.
401	Hold down clip-catch fastener.

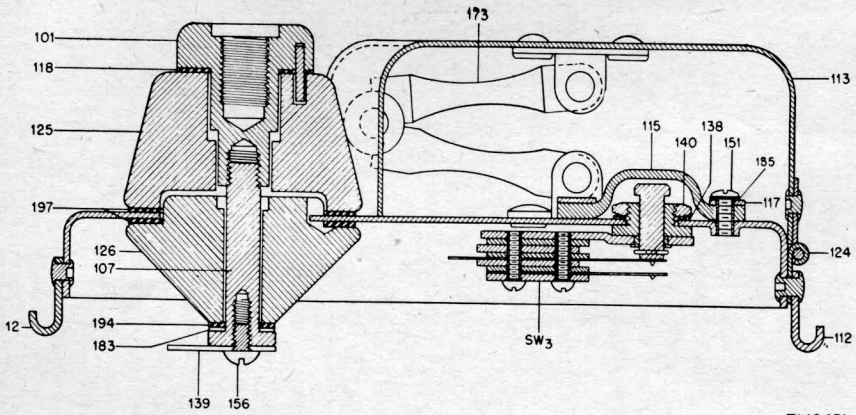

Figure 82. Antenna insulator and calibration switch parts.

TLI2431

<i>Reference No.</i>	<i>Description</i>
SW3	PRESS FOR DIAL LIGHT & CALIB. switch.
101	Antenna mounting bolt and pin assembly bushing.
107	Antenna fastening bolt.
112	Clip for clip-catch fasteners.
113	Panel cover.
115	Waterproof cover over PRESS FOR DIAL LIGHT & CALIB. switch.
117	Flange for waterproof cover 115.
118	Antenna insulator gasket.
124	Panel cover hinge.
125	Top insulator of antenna insulator assembly.
126	Bottom insulator of antenna insulator assembly.
138	Lockwasher secures calibration switch mounting nut.
139	Antenna insulator terminal lug.
140	Jack and jack waterseal assembly mounting nuts.
151	Diaphragm flange mounting screw.
156	Indicator adjustment knob fastening screw.
173	Front cover support.
183	Washer under antenna bolt fastening head.
185	Washer under heads of waterseal diaphragm and indicator window escutcheon mounting screws.
194	Waterseal washer for antenna fastening bolt, front panel mounting cap screws, and ground terminal stud and nut assembly.
197	Waterseals between antenna insulators and front panel.



## 115. Unsatisfactory Equipment Report WD AGO Form 468

a. This form is provided to supply a uniform method of submitting unsatisfactory equipment data to the chief of technical service at the earliest practical moment.

b. This form will *not* be used to report isolated defects or poor operation due to normal wear and tear, or accidental damage during battle conditions or amphibious landings.

c. This form is *not* to be used for replacement, repair, or issue of parts and equipment.

WAR DEPARTMENT  
**UNSATISFACTORY EQUIPMENT REPORT**

(Technical service)		DATE	
FOR	Signal Corps	MATERIEL	2 May 1944
FROM	(Organization)	(Station)	
5866 Signal Depot Co. APO 400		New York, N. Y.	
TO	(Direct superior headquarters)	(Station)	(Technical service)
Signal Officer - Army			
<b>COMPLETE MAJOR ITEM</b>			
NOMENCLATURE		TYPE	
Receiver & Transmitter BC-1000-A		Mini-Pack	
MODEL	A	MANUFACTURER	Galvin Mfg Co
U. S. A. REG. NO.	Order No. 15025-Phila-43	SERIAL NO.	No. 1213
EQUIPMENT WITH WHICH USED (IF APPLICABLE)		DATE RECEIVED	
SCR-300-A		28 March 1944	
<b>NOMENCLATURE OF DEFECTIVE COMPONENT</b>			
PART NO	Stock No	TYPE	
Ref. No. 301 3E4300-2		Cable, battery, assembly	
MANUFACTURER	Galvin Mfg. Co.	DATE INSTALLED	
		4 April 1944	
<b>LENGTH OF SERVICE</b>			
DATE OF INITIAL TROUBLE		TOTAL PERIOD OF OPERATION BEFORE FAILURE (FILL IN WHERE APPLICABLE)	
30 April 1944		YEARS	MONTHS
TOTAL	YEARS	MONTHS	DAYS
TIME	26	—	26
INSTALLED			52 Operational hours
<b>DESCRIPTION OF TROUBLE AND PROBABLE CAUSE</b>			
GIVE TYPE OF FAILURE, MECHANICAL, ELECTRICAL, WORKMANSHIP, MATERIAL, DESIGN			
Battery cable socket corroded and batteries short lived			
<b>UNUSUAL SERVICE CONDITIONS</b>			
GIVE BRIEF DESCRIPTION			
Heavy Rains			
TRAINING OR SKILL OF USING PERSONNEL (CHECK ONE)			
		POOR	FAIR
DESCRIPTION OF ANY REMEDIAL ACTION TAKEN			
Daily check to remove moisture and clean socket and plug.			
RECOMMENDATIONS			
Better seal between power plug and chassis.			
OFFICE	STATION	DATE	SIGNATURE
			E. A. Wilson
(Technical service)			ORIGINATING OFFICER
TO CHIEF Signal Officer Washington 25 D.C.			NAME
			E. A. WILSON
			RANK AND TITLE
			Capt. Signal Officer
			ORGANIZATION
			5866 Sig. Depot Co.

**INSTRUCTIONS**

1. It is imperative that the Chief of Technical Service concerned be advised at the earliest practical moment of any constructional, design, or operational defect in material. This form is designed to facilitate such reports and to provide a uniform method of submitting the required data.

2. This form will be used for reporting manufacturing, design or operational defects in material with a view to improving and correcting such defects, and for use in recommending modifications of material.

3. This form will not be used for reporting failures, isolated material defects or malfunctions of material resulting from fair wear-and-tear or accidental damage nor for the replacement, repair, or the issue of parts and equipment. It does not replace currently authorized operational or performance records.

4. Reports of malfunctions and accidents involving ammunition will continue to be submitted as directed in the manner described in AR 750-10 (Change No. 3).

W. D., A. G. O. Form No. 468  
1 December 1943

5. It will not be practicable or desirable in all cases to fill all blank spaces of the report. However, the report should be as complete as possible in order to expedite necessary corrective action. Additional pertinent information not provided for in the blank spaces should be submitted or inclosed to the form. Photographs, sketches or other illustrative material are highly desirable.

6. Where cases arise where it is necessary to communicate with a chief of service in order to secure safety to personnel, more expeditious means of communication are authorized. This form should be used to confirm reports made by more expeditious means.

7. This form will be made out by using or service organizations and forwarded to duplicate through command channels to the chief of technical service. The top copy to the chief of technical service receiving the report will forward an information copy to the Commanding General, Army Ground Forces or Army Air Forces, whichever is applicable, and to the Commanding General, Army Service Forces.

B. Necessity for using this form will be determined by the using or service troops.

d. The use of this form should be limited to reporting those cases of recurring equipment failures that can be attributed to poor design, poor workmanship or material, and improper usage or care by personnel. Such cases should be accompanied by drawings and samples when possible with recommendations showing the suggested remedy. All information called for on the form should be supplied when possible.

e. Examples of forms properly filled out for Radio Set SCR-300-A are shown in figures 83 and 84.

WAR DEPARTMENT UNSATISFACTORY EQUIPMENT REPORT					
FOR (Technical service) FROM Signal Corps (Organization)		MATERIEL (Station) 15 May 44		DATE	
TO 579 Sig. Repair Co. (Next superior headquarters)		APO 101 New York City (Station)			
Signal Officer (Technical service)		Army			
COMPLETE MAJOR ITEM					
NOMENCLATURE Receiver & Transmitter, BC-1000-A			TYPE Man-Pack		
MODEL A		MANUFACTURER Philco Corp.			
U. S. A. REG. NO. Order No. 10185-Phila-44		SERIAL NO. 1619		DATE RECEIVED 2 Feb. 1944	
EQUIPMENT WITH WHICH USED (IF APPLICABLE) SCR-300-A					
NOMENCLATURE OF DEFECTIVE COMPONENT					
PART NO. HN-130-A No. 2R275-130-A			TYPE 2 Section, 33" Flexible tubing near base.		
MANUFACTURER Philco Corp.			DATE INSTALLED 14 Feb. 44		
LENGTH OF SERVICE					
DATE OF INITIAL TROUBLE 18 Feb. 44		TOTAL PERIOD OF OPERATION BEFORE FAILURE (FILL IN WHERE APPLICABLE)			
MONTHS 1 Mo.		YEARS —	MONTHS —	DAYS 4	HOURS 20 hrs Operating time
DESCRIPTION OF TROUBLE AND PROBABLE CAUSE GIVE TYPE OF FAILURE, MECHANICAL, ELECTRICAL, WORKMANSHIP, MATERIAL, DESIGN Breaks bakelite shell at base of Antenna					
UNUSUAL SERVICE CONDITIONS Operating temperatures low, average 14°					
TRAINING OR SKILL OF USING PERSONNEL (CHECK ONE) POOR FAIR GOOD					
DESCRIPTION OF ANY REMEDIAL ACTION TAKEN Car in changing the angle of Antenna					
RECOMMENDATIONS A less brittle insulation for low operating temperatures					
OFFICE (Technical service)		STATION		DATE	
TO CHIEF Signal Officer Washington 25 D.C.					
NAME		RANK AND TITLE		SIGNATURE E. A. MALCOMB	
		Capt., Sig C			
STATION		RANK		ORGANIZATION	
				579 Sig Repair Co.	
INSTRUCTIONS					
1. It is imperative that the Chief of Technical Service concerned be advised at the earliest practical moment of any constructional, design, or operational defect in material. This form is designed to facilitate such reports and to provide a uniform method of submitting the required data.			5. It will not be practicable or desirable in all cases to fill all blank spaces of the report. However, the report should be as complete as possible in order to expedite necessary corrective action. Additional pertinent information not provided for in the blank spaces should be submitted as inclosures to the form. Photographs, sketches or other illustrative material are highly desirable.		
2. This form will be used for reporting manufacturing, design or operational defects in material with a view to improving and correcting such defects, and for use in recommending modifications of material.			6. When cases arise where it is necessary to communicate with a chief of service in order to assure safety to personnel, more expeditious means of communications are authorized. This form should be used to confirm reports made by more expeditious means.		
3. This form will not be used for reporting failures, isolated material defects or malfunctions of material resulting from fair wear-and-tear or accidental damage nor for the replacement, repair, or the issue of parts and equipment. It does not replace currently authorized operational or performance records.			7. This form will be made out by using or service organizations and forwarded in duplicate through command channels to the chief of technical service. The office of the chief of technical service receiving the report will forward an information copy to the Commanding General, Army Ground Forces or Army Air Forces, whichever is applicable, and to the Commanding General, Army Service Forces.		
4. Reports of malfunctions and accidents involving ammunition will continue to be submitted as directed in the manner described in AR 750-10 (Change No. 3).			8. Necessity for using this form will be determined by the using or service troops.		
W. D., A. G. O. Form No. 468 1 December 1943					

Figure 84. WD AGO Form 468, Unsatisfactory Equipment Report—sample form.

## Section V. ALIGNMENT PROCEDURES

### 116. Alignment Procedure Using Maintenance Equipment ME-40-( ) and Maintenance Kit M-53-( )

*a.* PRELIMINARY PROCEDURE. (1) Remove chassis of Radio Receiver and Transmitter BC-1000-A from the case.

(2) Before attempting to align Radio Receiver and Transmitter BC-1000-A, check all tubes, using the method outlined in paragraph 105 (burned-out tube location chart).

(3) Connect Battery BA-70 or BA-80 by using Cord No. 1X4956, carrying molded plug No. 30C41914 (CO-1108), furnished with Maintenance Equipment ME-40-( ), or plug the set into the battery as shown in figure 72.

(4) Plug in Handset TS-15-( ).

(5) Set Alignment Indicator I-210-( ) VOLTAGE SELECTOR SWITCH in the 4.5-volt position, short the test probe to the alligator clip, and adjust the calibrate knob for a hairline shadow on the indicator eye.

(6) Loosen the locknuts on L3, L5-1, L5-2, L5-3, L6-1, L6-2, L6-3, L7, and L8, just enough to leave some tension on the screw adjustment. (See fig. 85.) Use the spintite wrench found in Maintenance Equipment ME-40-( ).

(7) Screw phantom Antenna A-28-( ) into the antenna terminal of Radio Receiver and Transmitter BC-1000-A, and attach the ground lead to the GROUND FOR SHORT ANT. post.

(8) Turn on the set.

(9) Plug Alignment Indicator I-210-( ) into Battery BA-39.

(10) Throw the VTVI VOLTAGE SELECTOR SWITCH SW1 to the 30-volt position and turn the CALIBRATE knob to open the shadow angle on the indicator eye to 90°.

*b.* ALIGNING 4.3-MEGACYCLE OSCILLATOR. (1) Insert the test probe in metering socket pin No. 4 of Radio Receiver and Transmitter BC-1000-A and fasten the alligator clip to the chassis.

(2) Screw the adjustment of L3 counterclockwise as far as it will go.

**Caution:** While following this procedure in the field, never press the press for dial light & calib. button unless Phantom Antenna A-28-( ) is installed; otherwise the radiated signal will cause interference in nearby receivers and may reveal the location to the enemy.

(3) Hold down the PRESS FOR DIAL LIGHT & CALIB. button and screw adjustment L3 clockwise until the shadow becomes just a

hairline, or to minimum shadow if the hairline indication cannot be obtained. Screw out the adjustment one-half to three-quarters of a turn and tighten the locknut.

c. ALIGNING DISCRIMINATOR AND SECOND LIMITER. (1) With the VTVI VOLTAGE SELECTOR SWITCH SW1 in the 4.5-volt position, short the test probe to the alligator clip of the VTVI and adjust the knob for a hairline shadow on the indicator eye.

(2) Insert the test probe in pin No. 7 of the metering socket and fasten the alligator clip to the chassis.

(3) Hold down the PRESS FOR DIAL LIGHT & CALIB. button and adjust coil L8 so that a 5° or 10° shadow angle (0.5-volt) appears.

*Note.* In adjusting coil L8, note that there is a point where the shadow on the indicator eye is extremely active. At this point, adjust so that a shadow of approximately 5° or 10° appears. *Remember that an increase in positive voltage causes the eye to open, and an increase in negative voltage causes the eye to close or overlay.*

(4) After adjusting L8 to plus 0.5 volt, hold down the PRESS FOR DIAL LIGHT & CALIB. button, and adjust L7 for maximum shadow angle. If the angle opens too wide, 85° to 90°, during this adjustment, turn the L8 screw to the left slowly so that the angle reduces to 5° or 10°. Then, readjust L7 for maximum shadow angle, and tighten the locknut on L7.

(5) Still holding down the PRESS FOR DIAL LIGHT & CALIB. button, turn L8 slightly to the left until the shadow angle is reduced to a hairline. Tighten the locknut on coil L8 and make sure that the shadow angle remains a hairline after the locknut is tightened.

d. ALIGNING INTERMEDIATE-FREQUENCY AMPLIFIER. (1) With the VTVI VOLTAGE SELECTOR SWITCH SW1 set in the 4.5-volt position, open the shadow angle of VTVI by adjusting the calibrate knob.

(2) Insert the test probe in pin No. 2 of the metering socket and fasten the alligator clip to the chassis.

(3) Connect Oscillator VO-6-( ) by fastening one alligator clip on the flexible lead of the terminal box to the chassis, and the other alligator clip to the grid (pin No. 6) of the first mixer tube V7. (See fig. 86.)

(4) Set the HI-LO switch of the oscillator terminal box (dummy load) to the LO position.

(5) Increase the output by turning the attenuation control (marked INCREASE) of the oscillator to the right just far enough to change the angle of the shadow. If there is no indication, set the HI-LO switch of the oscillator terminal box to HI. If there still is no indication, disconnect Oscillator VO-6-( ), and set L6-2, L6-1, L5-3, L5-2, and L5-1 so that the adjusting screws are extended approximately ¼ inch above the locknuts. With the receiver turned to full volume, adjust the

i-f coil for maximum noise in the Headset TS-15-( ). Reconnect Oscillator VO-6-( ) as before.

(6) Adjust the input signal until a small indication is obtained on the indicator eye, and adjust L6-2, L6-1, L5-3, L5-2, and L5-1 in the order named to minimum shadow angle (negative volts). Tighten each locknut after each adjustment and watch the indicator eye to make sure that there is no misalignment.

*e. ALIGNING FIRST LIMITER.* (1) Set the VTVI VOLTAGE SELECTOR SWITCH to the 30-volt position.

(2) Insert the test probe in pin No. 3 of the metering socket, and adjust L6-3 for a minimum shadow angle. Turn off Oscillator VO-6-( ) by turning the INCREASE control counterclockwise until a click is heard, then remove the output leads of Oscillator VO-6-( ) from the radio set.

*Note.* Check to see that locknuts of L3, L5-1, L5-2, L5-3, L6-1, L6-2, L6-3, L7, and L8 are snug. Be careful not to change the settings of the adjustment screw.

*f. ALIGNING DISCRIMINATOR.* (1) Set the VTVI VOLTAGE SELECTOR SWITCH SW1 to the 4.5-volt position, ground the test probe, and adjust the calibrate knob for hairline shadow.

(2) Insert the test probe into pin No. 7 of the metering socket. There should be no change in the shadow angle from the original hairline setting. If there is, a slight readjustment of L5-1 or L5-2 should bring the indicator eye back to the hairline. A slight flutter in the shadow caused by r-f noise may be present when readjusting the coils.

*g. ALIGNING MASTER OSCILLATOR.* (1) Use the INDICATOR ADJUSTMENT to center the dial indicator line in the CHANNEL window.

**Caution:** Make the following adjustments quickly to prevent damage to r-f power amplifier tube V1.

(2) Turn the TUNING knob until C between channels 36 and 37 is directly under the indicator line. Press the switch on Handset TS-15-( ) and, with the handset to the ear, adjust trimmer C6G for zero beat. (See fig. 86.) The proper rotor-plate position is about three-fourths meshed. Check calibration on channel 15. If zero beat is not obtained on channel 15, oscillator inductance must be adjusted. (See par. 111.)

*Note.* Set the dial at channel 35 for all remaining adjustments.

*h. ALIGNING DOUBLER.* (1) With the test probe free, set the VTVI VOLTAGE SELECTOR SWITCH to the 30-volt position and, by adjusting the calibrate knob, open the indicator eye to approximately 90°.

(2) Insert the test probe into pin No. 5 of the metering socket.

(3) Press the switch on Handset TS-15-( ), and adjust C6E for minimum shadow.

*i. ALIGNING TRANSMITTER MIXER.* (1) With the test probe in pin No. 5 of the metering socket, press the switch on Handset TS-15-( ).

(2) Adjust C6C for minimum shadow.

j. ALIGNING TRANSMITTER RADIO-FREQUENCY AMPLIFIER. (1) Insert the test probe into pin No. 6 of the metering socket.

(2) Press the switch of Handset TS-15-( ).

(3) Adjust C6A for minimum shadow.

k. ALIGNING RECEIVER RADIO-FREQUENCY AMPLIFIER. Insert the test probe into pin No. 3 of the metering socket, and adjust C6K for minimum shadow. Do not press the switch on Handset TS-15-( ) for this step.

l. FINAL CHECK ON DISCRIMINATOR. (1) Set the VTVI VOLTAGE SELECTOR SWITCH SW1 on the 4.5-volt position, short the test probe to the alligator clip, and adjust the calibrate knob for hairline shadow.

(2) Insert the test probe into pin No. 7 of the metering socket. There should be no change in the shadow angle from the original hairline setting. If there is, a slight readjustment of L5-1 or L5-2 should bring the indicator eye back to the hairline indication.

### 117. Emergency Intermediate-Frequency Amplifier Alignment Using Crystal Calibration Circuit

a. PRELIMINARY PROCEDURE. To align the i-f amplifier system by this method, obtain a 4.3-mc signal from the transmitter mixer crystal in the set. To reduce the strength of the signal, use a dummy tube in the first mixer stage. A satisfactory dummy tube can be made by *cutting off all pins, except filament pins 1, 5, and 7 of one of the following: Tube JAN-114, JAN-1T4, or JAN-1R5. The filament in the tube selected must not be open.*

b. ALIGNMENT PROCEDURE. (1) Turn off the set, remove the first mixer tube V7, and insert the dummy tube in its place. Set the VTVI VOLTAGE SELECTOR SWITCH SW1 to the 30-volt position and insert the probe into pin No. 3 of the metering socket. Make sure the alligator clip is fastened to the chassis.

(2) Turn on the set.

(3) Hold down the PRESS FOR DIAL LIGHT & CALIB. button.

(4) Adjust L6-3 for maximum indication on the electronic voltmeter.

*Note.* If the set is considerably out of line, it may be necessary to adjust L6-2, L6-1, L5-3, and L5-2, to  $\frac{1}{4}$  inch above the locknuts, in order to obtain an initial reading at pin No. 3 of the metering socket. If the set is slightly out of alignment and only needs trimming, this reading may be over -15 volts; in this event, detune L5-3 and L5-2 so that, when L6-3 is adjusted, the reading is not over -15 volts. Then readjust L5-3 and L5-2 to give approximately maximum indication on the electronic voltmeter.

(5) Insert the probe of the electronic voltmeter into pin No. 2 of the metering socket. Adjust L6-2, L6-1, L5-3, and L5-2 respectively, for a maximum indication on the electronic voltmeter.

*Note.* If the voltage at pin No. 2 as indicated on the electronic voltmeter, exceeds  $-20$  volts, it may be difficult to adjust coils L6-2, L6-1, L5-3, and L5-2 to maximum. In this case, first detune L5-2 so that L6-2, L6-1, and L5-3 can be adjusted for a maximum reading of not over  $-20$  volts on the electronic voltmeter. Then adjust L5-2 in the same manner as L5-1, described in (6), (7), (8), and (9) below.

(6) Release the PRESS FOR DIAL LIGHT & CALIB. button and rotate the VOLUME control counterclockwise until a click is heard indicating the set is turned off.

(7) Replace the dummy tube with a tube known to be good and replace the tube shield.

(8) Insert the probe of the electronic voltmeter into pin No. 3 of the metering socket. Turn the set on.

(9) If necessary, adjust L5-2 first, then L5-1, for maximum indication of tube noise voltage.

*Note.* If the reading on the electronic voltmeter is above  $-15$  volts, adjust L5-1 to maximum reading on meter pin No. 2 instead of meter pin No. 3. If the voltmeter reading exceeds  $-15$  volts on pin No. 3, and no reading is obtained on pin No. 2, remove the receiver r-f tube. L5-1 can then be adjusted for a maximum reading on pin No. 3.

(10) Insert the probe of the electronic voltmeter into pin No. 7 of the metering socket. Hold down the PRESS FOR DIAL LIGHT & CALIB. button. Adjust L8 for a zero reading on the electronic voltmeter, then slightly detune L8 to give a positive reading of approximately 1 volt on the electronic voltmeter. (Turn the padder screw clockwise to produce a positive voltage.)

(11) With the electronic voltmeter still in pin No. 7 of the metering socket, and with the PRESS FOR DIAL LIGHT & CALIB. button still held down, adjust L7 for a maximum positive reading while readjusting L8 to maintain a reading of approximately 1 volt.

(12) With the PRESS FOR DIAL LIGHT & CALIB. button held down, readjust L8 to reach a zero reading on the electronic voltmeter.

(13) Release the PRESS FOR DIAL LIGHT & CALIB. button, but leave the set turned on and the electronic voltmeter probe in pin No. 7. If the voltage is greater than  $\pm 0.5$  volt, a final slight misalignment of L5-1 and L5-2 will bring the voltage to zero. Do not detune L5-1 and L5-2 by more than a quarter turn. The voltage will vary somewhat as the set is tuned over its frequency range. It is best to make this adjustment so that equal and opposite readings, with respect to zero, are obtained as the set is tuned over its entire range.

(14) Carefully tighten all locknuts. Recheck the voltage at pin No. 7 for a zero indication.

## 118. Alignment Procedure Using Electronic Voltmeter and Signal Generator

*a. PRELIMINARY PROCEDURE.* (1) Remove the chassis of Radio Receiver and Transmitter DC-1000-A from the case.

(2) Before attempting to align the set, check all the tubes, using the method outlined in table XII.

(3) Connect Radio Receiver and Transmitter BC-1000-A to Battery BA-70 or BA-80 with the battery cord furnished with Maintenance Equipment ME-40-( ), or plug the set directly into the battery.

(4) Plug in Handset TS-15-( ).

(5) Turn on the set.

(6) Check the discriminator, *b*(5), below.

(7) Loosen locknuts on L3, L5-1, L5-2, L5-3, L6-1, L6-2, L6-3, L7, and L8 just enough to allow adjustment of screws. (See fig. 85.)

(8) Turn on the 4.3-mc signal generator and allow it to warm up for at least 15 minutes.

(9) Use a suitable phantom antenna, such as phantom Antenna A-28-( ), if available. When employing this procedure in the field, do not press the PRESS FOR DIAL LIGHT & CALIB. button unless a phantom antenna is installed.

*b. ALIGNMENT. (1) 4.3-megacycle crystal oscillator. (a)* Insert the electronic voltmeter probe into pin No. 4 of the metering socket.

*(b)* Rotate the adjustment screw on L3 counterclockwise.

*(c)* Hold down the PRESS FOR DIAL LIGHT & CALIB. button and turn L3 clockwise, until the electronic voltmeter indicates —30 volts; then turn L3 counterclockwise about one-half or three-quarters of a turn and tighten the locknut. If the reading does not reach —30 volts, tune to the peak electronic voltmeter reading, and back L3 off one-quarter to three-quarters of a turn.

*(2) Discriminator and second limiter. (a)* Insert the electronic voltmeter probe into pin No. 7 of the metering socket.

*(b)* Hold down the PRESS FOR DIAL LIGHT & CALIB. button, and adjust L8 so that the electronic voltmeter reads approximately  $\pm 0.5$  volt. Adjust L7 for maximum reading. Finally, readjust L8 until the electronic voltmeter reads zero.

*(3) Intermediate-frequency amplifiers. (a)* Loosely couple the 4.3-mc signal generator to the first mixer tube V7 by placing a wire from the generator to a point near the first mixer tube. If greater coupling is necessary, connect the generator directly to grid (pin 6), through a small capacitor. Insert the electronic voltmeter probe into pin No. 7 of the metering socket, and adjust the signal-generator frequency until the electronic voltmeter reads zero. The signal generator is now set at the exact frequency of the 4.3-mc crystal in the radio set. (If Oscillator VO-6-( ) is used, this procedure is not necessary.)

*(b)* Insert the electronic voltmeter probe into pin No. 2 of the metering socket, and adjust the signal-generator output until the electronic voltmeter reads —0.5 volt. Adjust L6-2, L6-1, L5-3, L5-2, and L5-1



for maximum reading on the electronic voltmeter. Reduce the generator output as resonance is approached.

(4) *First limiter.* (a) Insert the electronic voltmeter probe into pin No. 3 on the metering socket, and adjust L6-3 for maximum reading on the electronic voltmeter.

(b) Disconnect the signal generator from tube V7.

(5) *Checking discriminator.* (a) Connect the electronic voltmeter probe to pin No. 7 and measure the voltage. (Be sure that no signal is being picked up by the receiver.) If the voltage is greater than  $\pm 0.5$  volt, a slight readjustment of L5-1 and L5-2 may be necessary to bring the voltage to zero.

(b) After tightening the locknuts, check the voltage at pin No. 7 again. This voltage should be no greater than  $\pm 0.5$  volt. Press the PRESS FOR DIAL LIGHT & CALIB. button; this should produce a zero voltage reading.

(6) *Master oscillator.* (a) Turn the TUNING knob until C between channels 36 and 37 is under the indicator line.

(b) Hold down the PRESS FOR DIAL LIGHT & CALIB. button and adjust trimmer C6G for zero beat. Check the calibration at channel 15.

**Caution:** In performing the steps in (7) and (8) below, do not leave the set in the transmit position too long, or damage may result to tube V1.

(7) *Doubler.* (a) Connect phantom Antenna A-28-( ).

(b) Set the dial to channel 35.

(c) Insert the electronic voltmeter probe into pin No. 5 of the metering socket.

(d) Press the handset switch and quickly adjust trimmer C6E for maximum indication on the electronic voltmeter.

(8) *Transmitter mixer.* With the electronic voltmeter connected to pin No. 5 of the metering socket, press the handset switch and quickly adjust trimmer C6C for maximum indication on the electronic voltmeter. This voltage should be at least  $-10$  volts.

(9) *Transmitter radio-frequency amplifier.* (a) Connect the test probe of the electronic voltmeter to pin No. 6 of the metering socket.

(b) Press the handset switch and adjust trimmer C6A for maximum voltage output. This voltage should be at least  $-25$  volts.

(10) *Receiver radio-frequency amplifier.* (a) Insert the electronic voltmeter probe into pin No. 3 of the metering socket.

(b) Connect Antenna AN-130-A to the set and connect the antenna ground lead to the GROUND FOR SHORT ANT. binding post on the front panel. Adjust trimmer C6K for maximum indication on the electronic voltmeter. This adjustment must be made while no signal is being received.

(11) *Discriminator (final check)*. Check the voltage at the output of the discriminator as explained in (5) above.

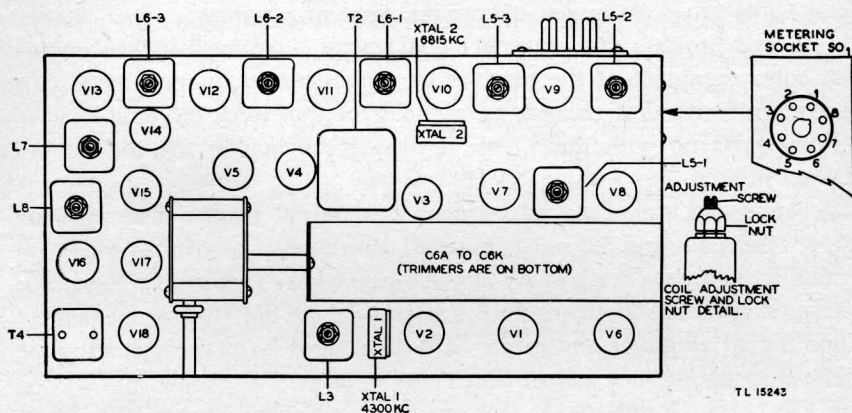

Figure 85. Radio Receiver and Transmitter BC-1000-A, alignment instruction detail—top view.

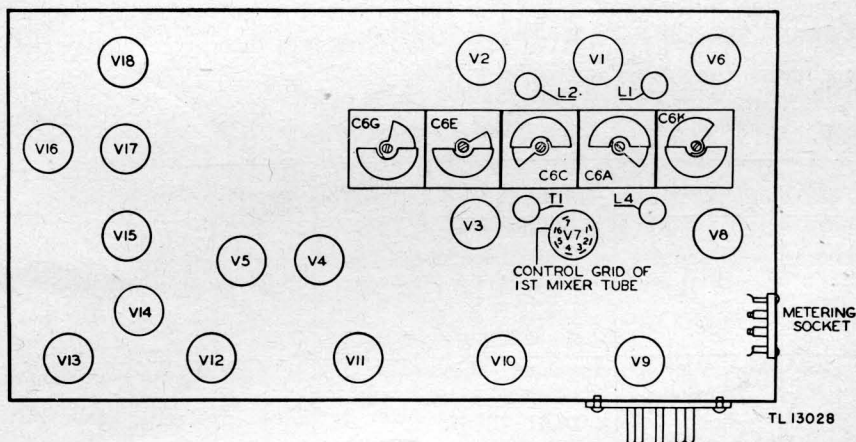

Figure 86. Radio Receiver and Transmitter BC-1000-A, alignment instruction detail—bottom view.

### 119. Use of Alignment Chart (table XVII)

a. *DETAILS IN TEXT*. Thorough study of the preceding text which describes in detail how to align Radio Receiver and Transmitter BC-1000-A in three ways is necessary before the alignment can be made properly. The alignment chart (table XVII) is intended as a handy outline guide to the step-by-step procedures and may be used with any of the three methods of alignment. Location of adjustments used in alignment is shown in figure 87.

b. **STAGE ADJUSTED.** This column lists the stage undergoing adjustment during alignment. Note that three separate checks are made on the discriminator to eliminate any change in adjustment that may have taken place while other alignment operations were in progress.

c. **INPUT SIGNAL.** An external signal source is required for one operation only, alignment of the receiver i-f amplifier and mixer stages. To assure symmetrical alignment, the signal generator must be set at exactly 4.3-mc, agreeing with the 4.3-mc crystal frequency in the set, as explained in step No. 3, table XVII.

d. **ADJUSTMENT.** Fine adjustment is required of the discriminator stage. Coils L7 and L8 must be tuned alternately in order to peak the second limiter plate coil exactly at the intermediate frequency. Tune the discriminator coil L8 to produce zero output at the resting frequency. Tune the i-f amplifier and mixer coils as accurately as possible the first time; then check each adjustment.

e. **METERING PIN SOCKET.** Reference to figure 88 will show the circuit resistor across which voltage is being measured during the alignment procedures.

f. **INDICATION OF ALIGNMENT.** Either an electronic voltmeter or Alignment Indicator I-210-( ) may be used as a voltage indicator. Scales to be used are offered as a guide; voltages to be reached are the minimums for proper operation.

Table XVII. Alignment chart

Step No.	Stage	Input signal	Adjustment	Metering socket pin No.	Indication of alignment
1.	V2 4.3 mc Xtal osc	Internal 4.3 mc: Press PRESS FOR DIAL L I G H T & CALIB. button.	L3	4	-30 v; back off $\frac{1}{2}$ to $\frac{3}{4}$ turn counterclock- wise.
2.	V14, V15 Discrimina- tor V13 2d limiter	Internal: Press PRESS FOR DIAL LIGHT & CALIB. but- ton.	L7 L8	7	L7 for maximum voltage (-4.5 v scale). L8 for zero volt- age (lowest scale).
3.	V11 3d i-f amp V10 2d mixer V9 2d i-f amp V8 1st i-f amp V7 1st mixer	External 4.3 mc to grid (pin 6) of 1st mixer (V7).  Set signal gen- erator exactly to 4.3 mc by obtaining zero voltage on pin 7.	L6-2 L6-1 L5-3 L5-2 L5-1	2	Maximum nega- tive voltage, keeping input signal low (-4.5 v scale).

Table XVII. Alignment chart

Step No.	Stage	Input signal	Adjustment	Metering socket pin No.	Indication of alignment
4.	V12 1st limiter	External 4.3 mc to grid (pin 6) of 1st mixer (V7).	L6-3	3	Maximum negative voltage (—30 v scale).
5.	(2d check) V14, V15 Discriminator	None	L5-1 or L5-2	7	Zero voltage (slight adjustment sufficient).
*6.	V4 Master osc	Internal: Press handset switch to transmit.	C6G	None	Zero-beat note on mark C between channel 36 and 37. Also on channel 15.
*7.	V3 Doubler	Internal: Set tuning to channel 35. Press handset switch to transmit.	C6E	5	Maximum negative voltage (—30 v scale).
*8.	V2 Transmitter mixer	Internal: Set tuning to channel 35. Press handset switch to transmit.	C6C	5	Maximum negative voltage (at least —10 v on —30 v scale).
*9.	V1 Transmitter r-f power amplifier	Internal: Set tuning to channel 35. Press handset switch to transmit.	C6A	6	Maximum negative voltage (at least —25 v on —30 v scale).
10.	V6 Receiver r-f amplifier	None	C6K	3	Maximum negative voltage (—30 v scale).
11.	(Final check) V14, V15 Discriminator	None	L5-1 or L5-2	7	Zero voltage slight adjustment sufficient).

For steps No. 1 through No. 9 use phantom Antenna A-28-( ).

For steps No. 10 and No. 11 use Antenna AN-130-A.

\* Perform these operations quickly to avoid damaging tubes.

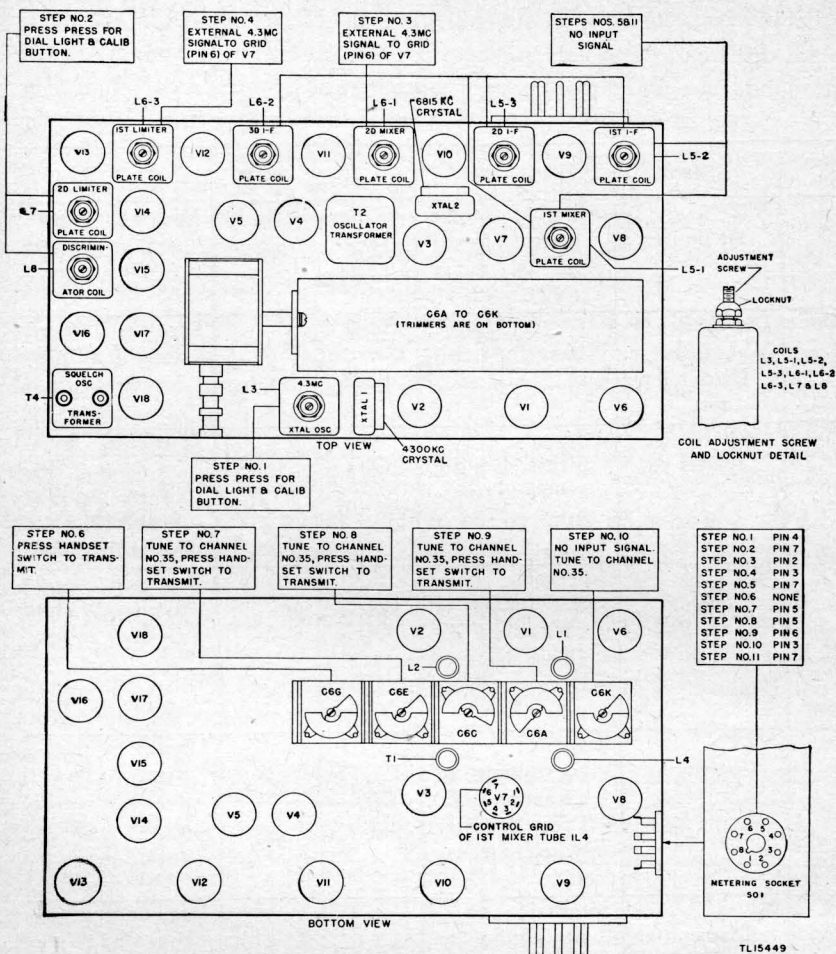

Figure 87. Radio Receiver and Transmitter BC-1000-A, location of adjustments used in alignment.

## Section VI. MINIMUM TEST REQUIREMENTS FOR REPAIRED RADIO RECEIVER AND TRANSMITTER BC-1000-A

### 120. General

This section is intended for the use of Signal Corps radio repair organizations as a guide in determining the quality of a repaired Radio Receiver and Transmitter BC-1000-A. The minimum test requirements outlined in this section may be performed by repair organizations possessing ade-

quate test equipment and the necessary skilled personnel. Performance of the tests described in this section will assure uniform high quality of operation of any repaired Radio Receiver and Transmitter BC-1000-A.

### 121. Instruments Required

a. SIGNAL GENERATOR. A signal generator with metered output covering the r-f range of frequencies is required. The generator should have provision for independent a-f output at audio frequencies ranging from 500 to 2,500 cycles. If the generator does not possess independent a-f capabilities, a separate audio-frequency generator may be used to furnish a-f signals.

b. OUTPUT METER WITH 4,000-OHM INPUT IMPEDANCE. The output meter included in Test Equipment IE-9-C or Test Set I-56-( ) is adequate. The meter should be equipped with Plug PL-55. Plug PL-55 will allow the meter to be plugged into the AUX. PHONE jack.

c. ELECTRONIC VOLTMETER. The RCA Voltohmyst or similar instrument is satisfactory.

d. SPARE RADIO SET SCR-300-A. This set will be used to check the modulation capability of the transmitter section of the set under test, and also in the *operational test*. This spare set should be in good operating order and should be checked prior to use to conform with the minimum test requirements given in this section.

e. PHANTOM ANTENNA. Phantom Antenna A-28-( ), part of Maintenance Equipment ME-40, should be used.

f. HANDSET TS-15-( ).

g. CONNECTOR. A short lead with an alligator clip attached to each end is necessary equipment.

h. CAPACITOR. A 0.1-microfarad, 400-volt, paper capacitor equipped with alligator clips is also required to perform these tests.

### 122. Receiver Sensitivity Test

a. Switch on the signal generator.

b. Remove the set from its case.

c. Connect a good battery to the set.

d. Turn on the set.

e. Allow the set to warm up for 30 seconds.

f. Check the supply voltages. Voltages should be as follows:

Filament supply—4.0 volts.

Receiver plate supply—85 volts.

Transmitter plate supply—140 volts.

g. Attach the phantom antenna to the antenna post on the set; connect the ground lead of the phantom antenna to the terminal GROUND FOR SHORT ANT. on the set.

*h.* Connect the hot lead of the signal generator to the phantom antenna and connect the ground lead of the generator to the ground terminal or the chassis of the set.

*i.* Insert the plugs of Handset TS-15-( ) into the proper jacks.

*j.* Plug the output meter into the AUX. PHONE jack.

*k.* Connect the electronic voltmeter between pins No. 3 and No. 8 of the metering socket.

*l.* Set the VOLUME control to maximum.

*m.* Set the SQUELCH control to the OFF position.

*n.* Referring to table XVIII, adjust the signal generator to check the frequency.

*o.* Tune the set to resonance with the generator as indicated by a minimum reading on the output meter, reduction of noise in the handset receiver, and maximum indication on the electronic voltmeter.

*p.* Proceed in accordance with the sensitivity test in table XVIII.

### 123. Receiver Squelch Sensitivity Test

*a.* Proceed as in the sensitivity test. (See par. 122, steps *a* to *n* incl.) See table XVIII and continue as follows.

*b.* Attenuate the signal-generator output to zero.

*c.* Turn the SQUELCH control on and adjust to the point where noise in the handset is eliminated.

*d.* Increase the generator output until the noise just appears.

### 124. Receiver Audio-Output Test

*a.* Proceed as in the sensitivity test. (See par. 122, steps *a* to *f* incl., *h*, *i*, *k*, and *l*.)

*b.* Connect the hot lead of the signal generator to pin No. 6 on tube socket V15 (a-f power amplifier); connect the ground lead of the generator to the chassis of the set.

*c.* Proceed in accordance with the receiver audio-output test on the chart.

### 125. Receiver Discriminator Test

*a.* Proceed as in the sensitivity test. (See par. 122, steps *a* to *f* incl., *h*, *k*, and *l*.)

*b.* Connect the electronic voltmeter probe to pin No. 7 on the metering socket.

*c.* Press the PRESS FOR DIAL LIGHT & CALIB. button and refer to the discriminator test A, table XVIII.

*d.* Release the PRESS FOR DIAL LIGHT & CALIB. button.

*e.* Tune the receiver over the entire frequency range. Watch the electronic voltmeter and refer to the discriminator test B, table XVIII.

*Note:* The meter reading given in the table applies *only when no signals are being received.*

f. Connect the *hot* lead on the signal generator to the first mixer grid, pin No. 6 on tube socket V7. Connect the ground lead of the generator to the chassis of the set.

g. Proceed in accordance with the discriminator test C, table XVIII.

### 126. Receiver Automatic-Frequency-Control Test

a. Proceed as in the sensitivity test. (See par. 122, steps *a* to *i*, incl., *k* and *l*.)

b. Connect the electronic voltmeter probe to pins No. 7 and No. 8 on the metering socket.

c. Short out the a-f-c circuit by connecting a short clip lead between the metal chassis and the sixth lug on the inner side of the long terminal strip nearest transformer T3A and T3B.

d. Proceed in the following manner, and refer to the a-f-c test, table XVIII.

e. Adjust the signal generator to the first input signal.

f. Tune the set to resonance with the generator as indicated by quieting of noise in the headset receiver and a reading of zero on the electronic voltmeter.

g. Reduce the signal-generator output to zero. *Note the output meter reading* (*n* volts on table XVIII).

h. Increase the signal-generator output to give the output meter reading on the chart (1/10 of *n* volts).

i. Tune the generator 40 kc above resonance as indicated in the table XVIII. *Do not change the generator attenuator adjustment as set in h.*

j. Remove the a-f-c shorting clip lead.

k. Note the output meter reading and compare it with the chart.

l. Replace the a-f-c shorting clip lead.

m. Tune the generator 40 kc below resonance as indicated on the chart. *Do not change generator attenuator adjustment as set in h.*

n. Remove the a-f-c shorting clip lead.

o. Note the output meter reading and compare it with table XVIII.

### 127. Meter Socket Voltage Test

a. Proceed as in the sensitivity test. (See par. 122, steps *a* to *f*, incl., *h*, *k* and *l*.)

b. Tune the set to channel 20 (44,000 kc).

c. Connect the ground lead of the electronic voltmeter to the metal chassis of the set.

d. Place the d-c voltage lead of the electronic voltmeter into pin No. 1 of the metering socket.

e. Press the transmit switch on the handset, and note the electronic voltmeter reading.



f. Repeat steps (4) and (5) for pins Nos. 2, 3, 4, 5, 6, and 7 of the metering socket.

g. The following minimum voltages should be obtained:

Pin No.	Test	Measurement (v)
1	Master oscillator grid	— 4.5
2	1st limiter grid	— 0.5
3	2nd limiter grid	—17
4	Transmitter mixer	—17
5	Transmitter r-f power amplifier grid	—10
6	Receiver r-f amplifier grid	—20
7	Discriminator output	± 0.5

### 128. Transmitter Modulation Capability Test

a. Proceed as in the sensitivity test. (See par. 122 steps *a* to *f*, incl., *h*, *k*, and *l*.)

b. Turn on *spare* Radio Receiver and Transmitter BC-1000-A and prepare the set for receiver operation with the VOLUME at maximum and the SQUELCH OFF.

c. Attach Antenna AN-130-A to *spare* Radio Receiver and Transmitter BC-1000-A.

d. Connect the electronic voltmeter probe to pin No. 3 on the metering socket of *spare* Radio Receiver and Transmitter BC-1000-A. The alligator clip must be fastened to the chassis.

e. Connect a 6-inch length of nonshielded wire to the *hot* lead of the signal generator. Connect the ground lead of the generator to the chassis of *spare* Radio Receiver and Transmitter BC-1000-A. (The 6-inch length of wire is used as a radiator for the signal generator.)

f. Tune the signal generator to 44,000 kc and set the output to approximately 100 microvolts.

g. Tune *spare* Radio Receiver and Transmitter BC-1000-A to resonance with the signal generator as indicated by the maximum reading on the electronic voltmeter and by the reduction of noise in the handset receiver.

h. Reduce the generator output to 4 or 5 microvolts.

i. Remove the 6-inch wire from the *hot* lead of the generator.

j. Connect the *hot* lead of the generator to the phantom antenna of the set under test. Connect the ground lead of the generator to the chassis.

k. Connect the electronic voltmeter between pins No. 3 and No. 8 of the metering socket of set under test.

l. Tune the set under test to channel 20 (44,000 kc) as indicated by

the maximum reading on the electronic voltmeter and quieting of noise in the handset receiver.

*m.* Remove the signal-generator connections from the set under test. Reduce the output to zero. *Do not change the tuning setting.*

*n.* Remove the electronic voltmeter from the set under test and connect it between pins No. 7 and No. 8 of the metering socket on *spare* Radio Receiver and Transmitter BC-1000-A.

*o.* Connect the *hot* lead of the a-f signal source through a 0.1-mf capacitor to lug No. 1 of transformer T3A of the set under test. Connect the ground lead of the a-f signal source to the chassis.

*p.* Set the a-f signal source to 1,000 cycles and adjust the output to 0.4 volts.

*q.* Press and hold in the transmit position the switch on the handset of the set under test.

*r.* Rotate the TUNING dial of *spare* Radio Receiver and Transmitter BC-1000-A toward channel 21 until the electronic voltmeter reading falls to approximately zero. *Slowly and carefully stop turning the dial at this point.*

*s.* Release the receive-transmit switch of the set under test.

*t.* Remove the electronic voltmeter lead from pin No. 7 of the metering socket of *spare* Radio Receiver and Transformer BC-1000-A and insert the lead into pin No. 3 of the metering socket.

*u.* Connect a 6-inch wire (radiator) to the signal generator as in *e* above.

*v.* Increase the generator output to approximately 100 microvolts.

*w.* Carefully tune the generator above 44,000 kc until the generator is in resonance with *spare* Radio Receiver and Transmitter BC-1000-A as indicated by the maximum electronic voltmeter reading and the quieting of noise in the handset receiver. Note the *new* setting of the signal-generator dial.

*x.* *The difference between the new generator frequency setting and the original setting (44,000 kc) should be at least 35 kc.*

### 129. Operational Test

*a.* Assemble the set and battery in the case, and place them on a *soft rubber* or *felt* pad, or on a *padded bench*.

*b.* Attach the phantom antenna.

*c.* Turn on the set.

*d.* Set up the *spare* set 15 or more feet away from set under test. Turn on the *spare* set.

*e.* Attach Antenna AN-130-A to the *spare* set.

*f.* Adjust *both* sets for operation.

- g. Tune both sets to channel 1.
- h. Carry on conversation between the sets.
- i. Voice transmission of the set under test should be clear and understandable.
- j. Reception in the set under test must likewise be clear and easily understood.
- k. Operate VOLUME control of the set under test. As the control is rotated, the sound must change uniformly.
- l. Turn on the SQUELCH control of the set under test, and rotate it just far enough to eliminate noise when no signal is being received. Then pick up the signal from the *spare* set.
- m. The set under test must receive a clear, understandable signal. No noise must be heard when the signal is not being received.
- n. Turn off the SQUELCH control of the set under test.
- o. While the set under test is receiving a signal from the spare set, tap the set repeatedly in various places with a *padded* mallet. Listen for cutting-off of the signal or extraneous noise indicative of loose contacts or microphonic conditions. (Tapping stimulates vibration. DO NOT STRIKE set hard enough to damage the set.)
- p. While the set under test is transmitting a signal, listen to the signal on the *spare* set. Tap the set under test with a *padded* mallet as in *o* above and listen for possible cutting-off or distortion of the signal due to loose contacts or microphonic conditions.
- q. Repeat the above tests on channels 20 and 39.
- r. Push the PRESS FOR DIAL LIGHT & CALIB. button of the set under test. The dial lamp should light.

### 130. Moving Parts and Finish

In addition to the electrical tests described above, the receiver should be checked for smoothness of operation in moving or rotating parts, and for condition of the finish.

- a. Check the receiver for cleanliness, *inside and outside*.
- b. Rotate all tuning and volume controls. These should be smooth in operation across the arc of rotation. There should be no appreciable backlash or slipping of controls.
- c. Try all switches. They should snap firmly into each contact position.
- d. Insert the appropriate plugs into the proper jacks. They should seat firmly and make good contact.
- e. Try the DIAL LOCK. It should prevent the TUNING dial from rotating. The dial should not shift when the lock is being tightened.
- f. Inspect the condition of the finish and plating. Both the paint and plating should be free from corrosion, blisters, flaking, bare or worn spots, and deep scratches.

Table XVIII. Minimum test requirements

Receiver tests	Input signal		Output meter reading	Electronic voltmeter reading
	Frequency	Voltage		
Sensitivity	40,200 kc	4.5 $\mu\text{v}$	Minimum	Maximum
	40,200 kc	0 $\mu\text{v}$	X v	.....
	40,200 kc	2.5 $\mu\text{v}$ or less	1/10 of X	.....
	44,000 kc	4.5 $\mu\text{v}$	Minimum	Maximum
	44,000 kc	0 $\mu\text{v}$	Y v	.....
	44,000 kc	2.5 $\mu\text{v}$ or less	1/10 of Y	.....
	47,800 kc	4.5 $\mu\text{v}$	Minimum	Maximum
	47,800 kc	0 $\mu\text{v}$	Z v	.....
Squelch sensitivity	43,000 kc	4.5 $\mu\text{v}$	Minimum	Maximum
	43,000 kc	0 $\mu\text{v}$	(See par. 123c.)	
	43,000 kc	0.5 $\mu\text{v}$ or less	(See par. 123d.)	
Audio output	250 cycles	3 v	0.5 v or more	.....
	1,000 cycles	.3 v	0.7 v or more	.....
	2,000 cycles	3 v	0.7 v or more	.....
	2,500 cycles	3 v	0.5 v or more	.....
Discriminator				
A	(See par. 125c)		.....	$\pm 0.25$ v
B	0	0	.....	$\pm 1.0$ v (See par. 125e)
C	4,300 kc	10,000 $\mu\text{v}$	.....	0 v
	4,315 kc	10,000 $\mu\text{v}$	(Difference between these values must not exceed 1.5 v)	5 v or more 5 v or more
	4,285 kc	10,000 $\mu\text{v}$		
Automatic frequency control	40,000 kc	2 $\mu\text{v}$	Minimum	0 v
	40,000 kc	0 $\mu\text{v}$	n volts	.....
	40,000 kc	(See par. 126h)	1/10 of n v	.....
	40,040 kc	(See par. 126i to k, incl.)	1/3 of n v or less	.....
	39,960 kc	(See par. 126l to o, incl.)	1/3 of n v or less	.....

## CAPACITORS

<i>Ref. No.</i>	<i>Value</i>	<i>Function</i>
C1	500 mmf	Antenna coupling
C2	100 mmf	V6, input coupling
C3	200 mmf	V1, tracking
C4	15 mmf	L1, shunt
C5	0.01 mf	V1, plate bypass
C6	5 gang, each	Gang tuning
	12 to 37 mmf	
C6A	12 to 37 mmf	Trimmer across C6B
C6B	12 to 37 mmf	L1, tuning
C6C	12 to 37 mmf	Trimmer across C6D
C6D	12 to 37 mmf	L2, tuning
C6E	12 to 37 mmf	Trimmer across C6F
C6F	12 to 37 mmf	T1, tuning
C6G	12 to 37 mmf	Trimmer across C6H
C6H	12 to 37 mmf	T2, tuning
C6J	12 to 37 mmf	L4, tuning
C6K	12 to 37 mmf	Trimmer across C6J
C7	500 mmf	V1, screen bypass
C8	0.01 mf	V1, meter bypass
C9	100 mmf	V1, grid coupling
C10	200 mmf	V2, tracking
C11	20 mmf	L2, shunt
C12	0.01 mf	V2, plate bypass
C13	25 mmf	L3, crystal oscillator tank
C14	500 mmf	V2, oscillator anode bypass
C15	500 mmf	V2, coupling for calibration
C16	15 mmf	V2, grid coupling
C17	0.01 mf	V2, meter bypass
C18	20 mmf	T1, shunt
C19	0.01 mf	V3, plate bypass
C20	0.01 mf	V3, screen bypass
C21	100 mmf	V3, grid coupling
C23	0.01 mf	V4, plate bypass
C24	100 mmf	R14, bypass
C25	0.01 mf	V4, meter bypass
C26	0.01 mf	V4, screen bypass
C27	0.01 mf	V5, screen bypass
C28	25 mmf	V5, phase shift
C29	0.01 mf	V5, audio coupling
C30	0.01 mf	V5, a-f-c filter
C31	0.01 mf	V6, meter bypass
C32	0.01 mf	V6, screen bypass
C33	200 mmf	V6, plate bypass
C34	20 mmf	L4, shunt
C35	100 mmf	V7, grid coupling
C36	25 mmf	L5-1, shunt
C37	100 mmf	V8, grid coupling
C38	0.01 mf	V7, plate bypass
C39	0.01 mf	V8, screen bypass
C40	25 mmf	L5-2, shunt
C41	500 mmf	V9, grid coupling
C42	0.01 mf	V8, plate bypass
C44	25 mmf	L5-3, shunt
C45	100 mmf	V10, grid coupling
C46	0.01 mf	V9, plate bypass
C47	15 mmf	V10, oscillator grid bypass
C48	0.01 mf	V15, control grid bias filter
C49	25 mmf	L6-1, shunt
C50	100 mmf	V11, grid coupling
C51	0.01 mf	V10, plate bypass
C52	0.01 mf	B plus bypass
C53	25 mmf	L6-2, shunt
C54	100 mmf	V12, grid coupling
C55	0.01 mf	V11, plate bypass

<i>Ref. No.</i>	<i>Value</i>	<i>Function</i>
C56	0.01 mf	V12, meter bypass
C57	0.01 mf	L6-3, shunt
C58	100 mmf	V13, grid coupling
C59	0.01 mf	V12, plate bypass
C60	0.01 mf	V13, meter bypass
C61	0.01 mf	V13, screen bypass
C62	25 mmf	L7, shunt
C63	50 mmf	Couples L7 to L8
C64	0.01 mf	V13, plate bypass
C65	100 mmf	L8, shunt and compensator
C66	100 mmf	L8, shunt and compensator
C67	100 mmf	V14, V15, discriminator output by-pass
C68	0.01 mf	V15, grid coupling
C69	10 mmf	V14, V15, discriminator coupling
C70	0.01 mf	V14, V15, discriminator meter by-pass
C71	0.01 mf	V12, filament bypass
C72	0.006 mf	T3B, primary bypass
C73	0.01 mf	V15, grid bias filter
C74	0.01 mf	V15, filament bypass
C75	0.01 mf	V6, filament bypass
C76	0.01 mf	V7, filament bypass
C77	0.01 mf	V13, filament bypass
C78	0.01 mf	V10, filament bypass
C79	0.01 mf	V9, filament bypass
C80	0.01 mf	V9, filament bypass
C81	0.01 mf	V14, filament bypass
C82	0.01 mf	V14, filament bypass
C83	0.01 mf	V8, filament bypass
C84	0.01 mf	V5, filament bypass
C85	0.01 mf	V11, filament bypass
C86	0.01 mf	V11, filament bypass
C87	0.01 mf	V1, filament bypass
C88	0.01 mf	V2, filament bypass
C89	100 mmf	V16, coupling
C90	100 mmf	V16, high pass filter
C91	100 mmf	V16, screen bypass
C92	50 mmf	V16, coupling, noise amplifier to rectifier
C93	0.01 mf	V17, grid filter
C94	106 mmf	V18, coupling, squelch oscillator to diode
C95	100 mmf	T4, primary shunt
C96	100 mmf	R72, bypass
C97	0.01 mf	V18, plate bypass
C99	11 mmf	T2, primary shunt and compensator

## RESISTORS

R1	220 ohms	V1, plate decoupling
R2	220 ohms	V1, screen dropping
R3	1 meg	V1, meter filter
R4	0.22 meg	V1, grid bias
R5	220 ohms	V2, plate decoupling
R6	2,200 ohms	V2, screen dropping
R7	1 meg	V2, meter filter
R8	0.22 meg	V2, grid bias
R9	10,000 ohms	V3, plate dropping
R10	5,600 ohms	V3, screen dropping
R11	5,600 ohms	V4, plate decoupling
R12	68,000 ohms	V3, grid bias
R13	1 meg	V4, meter filter
R14	22,000 ohms	V4, grid bias
R15	5,600 ohms	V4, screen dropping
R16	2,200 ohms	V5, screen dropping
R17	0.1 meg	V5, control grid

<i>Ref. No.</i>	<i>Value</i>	<i>Function</i>
R18	0.47 meg	V5, a-f-c filter
R19	22,000 ohms	V5, phase shift
R20	22,000 ohms	T3A, secondary load
R21	330 ohms	T3A, microphone current
R22	39 ohms	V1, filament shunt
R23	0.68 meg	V6, control grid
R24	0.1 meg	V6, screen dropping
R25	10,000 ohms	V6, plate decoupling
R26	3.3 meg	V7, control grid
R27	22,000 ohms	V7, plate decoupling
R28	0.22 meg	V8, control grid
R29	39,000 ohms	V8, screen dropping
R30	10,000 ohms	V8, plate decoupling
R31	0.22 meg	V9, control grid
R32	1 meg	V6, meter filter
R33	22,000 ohms	V9, plate decoupling
R34	0.22 meg	V10, control grid
R35	1 meg	V15, grid filter
R37	0.1 meg	V10, oscillator bias
R39	10,000 ohms	V10, plate decoupling
R40	0.1 meg	V11, control grid
R41	22,000 ohms	V11, plate dropping
R42	0.1 meg	V12, grid bias
R43	1 meg	V12, meter filter
R44	22,000 ohms	V12, plate and screen dropping
R45	0.1 meg	V13, control grid
R46	1 meg	V13, meter filter
R47	68,000 ohms	V13, screen dropping
R48	47,000 ohms	V13, plate decoupling
R49	0.22 meg	V14, discriminator load
R50	0.1 meg	V14, V15 discriminator filter
R51	0.5 meg pot	V15, volume control
R52	39,000 ohms	V15, voltage filter
R53	0.22 meg	V15, discriminator load
R54	1 meg	V14, V15, discriminator meter filter
R55	0.47 meg	V5, a-f-c filter
R56	22 ohms	LM1, pilot light shunt
R57	4.7 ohms	V1, V2, filament dropping
R58	0.47 meg	V16, high pass filter
R59	0.47 meg	V16, control grid
R60	68,000 ohms	V16, screen dropping
R61	1 meg	V16, diode load
R62	0.1 meg	V16, plate load
R63	3.3 meg	V17, grid filter
R64	3.3 meg	V17, grid decoupling
R65	2.2 meg	V17, bleeder
R66	0.5 meg pot	V17, squelch control
R67	0.22 meg	V17, bleeder
R68	68,000 ohms	V17, plate
R69	68,000 ohms	V17, plate dropping
R70	1 meg	V18, diode load
R71	0.47 meg	V15, voltage filter
R72	0.1 meg	V18, grid bias
R73	68,000 ohms	V18, plate decoupling
R74	1 meg	V6, grid voltage divider
R75	15,000 ohms	V5, phase shift
R76	270 ohms	V4, filament shunt
R77	10,000 ohms	V10, oscillator grid
R78	22,000 ohms	V10, screen dropping

# APPENDIX

---

## Section I. MAINTENANCE PARTS LIST

### 1. Maintenance Parts List for Radio Set SCR-300-A

For maintenance parts information, see appropriate sections of Army Service Forces Signal Supply Catalogs SIG 7-SCR-300, Organizational Spare Parts, and SIG 8-SCR-300 (Revised), Higher Echelon Spare Parts.

## Section II. REFERENCES

### 2. Army Regulations

AR 380-5, Safeguarding Military Information.

### 3. Parts List

SIG 1, Introduction to ASF Signal Supply Catalogue.

SIG 2, Complete Index to ASF Signal Supply Catalogue.

SIG 3, List of Items for Troop Issue.

SIG 4-1, Allowances of Expendable Supplies.

SIG 4-2, Allowances of Expendable Supplies for Schools, Training Centers, and Boards.

SIG 5, Stock List of All Items.

\*SIG 6, Sets.

SIG 7 (series), Organizational Spare Parts.

SIG 8 (series), Higher Echelon Spare Parts.

SIG 10, Fixed Plant Maintenance List.

SB 11-6, Dry Battery Supply Data.

SB 11-8, Chests for Running Spares for Radio Sets SCR-506-( ), SCR-508-( ), SCR-528-( ), and SCR-538-( ).

### 4. Technical Manuals on Auxiliary Equipment

TB SIG 21, Installation of Loudspeaker LS-3.

TM 11-300, Frequency Meter Sets SCR-211-( ).

TM 11-303, Test Sets I-56-C, -D, -H, and -J.



TM 11-315, Maintenance Equipment ME-40-( ) and Maintenance Kit ME-53-( ).

TM 11-321, Test Set I-56-E.

TM 11-472, Repair and Calibration of Electrical Measuring Instruments.

TM 11-2613, Voltohmmeter I-166.

TM 11-2626, Test Unit I-176.

TM 11-2627, Tube Tester I-177.

## 5. Painting, Preserving, and Lubrication

SB 11-10, Signal Corps Kit and Materials for Moisture and Fungi-Resistant Treatment.

TB SIG 6, A Method of Prolonging the Life of Dry Batteries.

TB SIG 13, Moistureproofing and Fungiproofing Signal Corps Equipment.

## 6. Shipping Instructions

U. S. Army Spec No. 100-14A Army-Navy General Specification for Packaging and Packing for Oversea shipment.

## 7. Decontamination

TM 3-220, Decontamination.

## 8. Demolition

FM 5-25, Explosives and Demolitions.

## 9. Camouflage

FM 5-20, Camouflage, Basic Principles.

## 10. Other Technical Publications

FM 21-6, List of Publications for Training.

FM 21-7, List of War Department Films, Film Strips, and Recognition Film Slides.

FM 21-8, Military Training Aids.

FM 21-40, Defense Against Chemical Attack.

FM 24-5, Signal Communication.

FM 24-6, Radio Operators Manual, Army Ground Forces.

FM 24-9, Combined United States-British Radiotelephone (R/T) Procedure.

FM 24-11, Combined Operating Signals.

FM 24-12, Army Extract of Combined Operating Signals.

FM 24-18, Radio Communication.

TB SIG 5, Defense Against Radio Jamming.

- TB SIG 25, Preventive Maintenance of Power Cords.  
 TB SIG 66, Winter Maintenance of Ground Signal Equipment.  
 TB SIG 72, Tropical Maintenance of Ground Signal Equipment.  
 TB SIG 75, Desert Maintenance of Ground Signal Equipment.  
 TM 1-455, Electric Fundamentals.  
 TM 11-227, Signal Communication Equipment Directory, Radio  
 Communication Equipment.  
 TM 11-310, Schematic Diagrams for Maintenance of Ground  
 Radio Communication Sets.  
 TM 11-314, Antennas and Antenna Systems.  
 TM 11-453, Shop Work.  
 TM 11-454, The Radio Operators.  
 TM 11-455, Radio Fundamentals.  
 TM 11-462, Reference Data.  
 TM 11-483, Suppression of Radio Noises.  
 TM 11-496, Training Text and Applicatory Exercises for Amplitude  
 Modulated Radio Sets.  
 TM 11-499, Radio Propagation Handbook.  
 TM 38-250, Basic Maintenance Manual.

## 11. Forms

WD AGO Form 468, Unsatisfactory Equipment Report.

## 12. List of Abbreviations

a-c	alternating current
a-f	audio frequency
A.F.C., a-f-c	automatic fre- quency control
amp	ampere
amplr	amplifier
ANT	antenna
AUX.	auxiliary
BC	basic component
CALIB.	calibration
cps	cycles per second
d-c	direct current
discr	discriminator
fig.	figure
fil	filament
ID	inside diameter
I.F., i-f	intermediate fre- quency
INF	infinity

kc	kilocycles
ma	milliamperes
max	maximum
mc	megacycles
meg	megohms
mf	microfarads
Mfd	manufactured
mh	millihenries
MIC.	microphone
min	minimum
mmf	micromicrofarads
mo	master oscillator
mod	modulator
MTR	meter
NC	no connection
No.	number
OD	outside diameter
od	olive drab
osc	oscillator
par.	paragraph
Pos.	position
PWR	power
QM	quartermaster
react mod	reactance modu- lator
recvr	receiver
rect	rectifier
R-F, r-f	radio frequency
SCR	Signal Corps radio
Sect	section
SO	socket
STD BC	standard broadcast
v	voltage, volts
VT	vacuum tube
VTVI	vacuum-tube voltage indicator
WD	War Department;
AGO	The Adjutant General's Office
x	by
xmtr	transmitter
xtal	crystal
uh	microhenries
$\Omega$	ohms

# RESISTOR COLOR CODES

**RMA COLOR CODE FOR  
FIXED COMPOSITION RESISTORS**

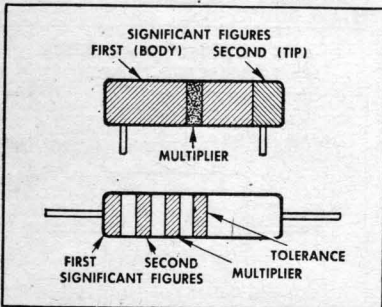

Insulated fixed composition resistors with axial leads are designated by a natural tan background color. Non-insulated fixed composition resistors with axial leads are designated by a black background color.

**AWS COLOR CODE FOR  
FIXED COMPOSITION RESISTORS**

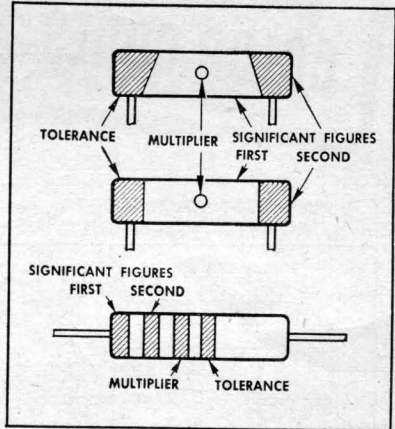

The exterior body color of insulated resistors may be any color except black. The usual color is natural tan. The exterior body color of uninsulated resistors with axial leads may be either black or white. The exterior, body color of uninsulated resistors with radial leads may be black or it may be the color of the first significant figure of the resistance value.

COLOR	SIGNIFICANT FIGURE	MULTIPLIER	TOLERANCE (PERCENT)
BLACK	0	1	
BROWN	1	10	
RED	2	100	
ORANGE	3	1000	
YELLOW	4	10,000	
GREEN	5	100,000	
BLUE	6	1,000,000	
VIOLET	7	10,000,000	
GRAY	8	100,000,000	
WHITE	9	1,000,000,000	
GOLD		0.1	5
SILVER		0.01	10
NO COLOR			20

**RMA:** Radio Manufacturers Association  
**AWS:** American War Standard  
 (American Standards Association)

# CAPACITOR COLOR CODES

**RMA 3-DOT COLOR CODE FOR MICA-DIELECTRIC CAPACITORS**

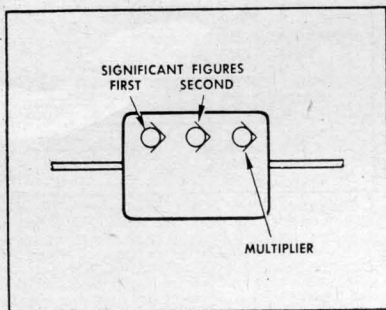

Capacitors marked with this code have a voltage rating of 500 volts.

**RMA 6-DOT COLOR CODE FOR MICA-DIELECTRIC CAPACITORS**

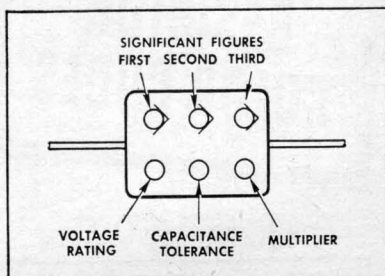

**AWS 6-DOT COLOR CODE FOR PAPER-DIELECTRIC CAPACITORS**

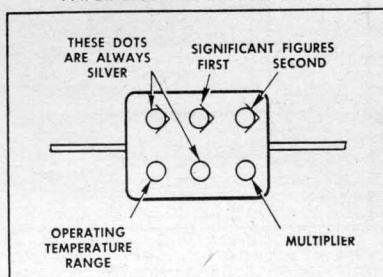

The silver dots serve to identify this marking. The sixth dot shows whether the capacitor has a maximum operating temperature of 167°F (black) or 185°F (brown)

COLOR	SIGNIFICANT FIGURE	MULTIPLIER		VOLTAGE RATING (VOLTS)	CHARACTERISTIC (AWS MICA-DIELECTRIC)
		RMA MICA- AND CERAMIC-DIELECTRIC AWS MICA- AND PAPER-DIELECTRIC	AWS CERAMIC-DIELECTRIC		
BLACK	0	1	1		A
BROWN	1	10	10	100	B
RED	2	100	100	200	C
ORANGE	3	1000	1000	300	D
YELLOW	4	10,000		400	E
GREEN	5	100,000		500	F
BLUE	6	1,000,000		600	G
VIOLET	7	10,000,000		700	
GRAY	8	100,000,000	0.01	800	
WHITE	9	1,000,000,000	0.1	900	
GOLD		0.1		1000	
SILVER		0.01		2000	
NO COLOR				500	

*Capacitor Color Codes.*

**AWS 6-DOT COLOR CODE FOR MICA-DIELECTRIC CAPACITORS**

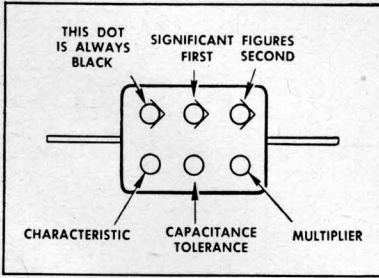

The black dot serves to identify the AWS marking. Capacitors marked with this code are rated at 500 volts, except the following. AWS type CM35 capacitors with capacitances of 6,800, 7,500, and 8,200 micromicrofarads, and AWS type CM40 capacitors with capacitances of 9,100 and 10,000 micromicrofarads are rated at 300 volts.

RMA: Radio Manufacturers Association  
 AWS: American War Standard  
 (American Standards Association)

---

NOTE: These color codes give all capacitances in micromicrofarads.

**AWS COLOR CODE FOR TUBULAR CERAMIC-DIELECTRIC CAPACITORS**

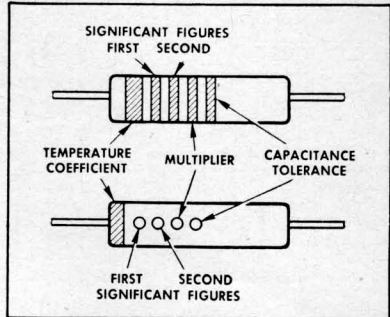

Capacitors marked with this code have a voltage rating of 500 volts.

**RMA COLOR CODE FOR TUBULAR CERAMIC-DIELECTRIC CAPACITORS**

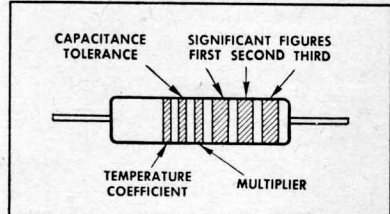

Capacitors marked with this code have a voltage rating of 500 volts.

CAPACITANCE TOLERANCE				TEMPERATURE COEFFICIENT OF CAPACITANCE x10 <sup>-4</sup> MMF/MMF/°C
RMA & AWS MICA- AND PAPER-DIELECTRIC (PERCENT)	RMA CERAMIC-DIELECTRIC (PERCENT)	AWS CERAMIC-DIELECTRIC GREATER THAN 10 MMF (PERCENT)	AWS CERAMIC-DIELECTRIC LESS THAN 10 MMF (MMF)	
20	20	20	2.0	0
1	1	1		- 30
2	2	2		- 80
3	3	2.5	0.25	-150
4	4			-220
5	5	5	0.5	-330
6	6			-470
7	7			-750
8	2.5			+ 30
9	10	10	1.0	Not specified
5				
10				
20				

TL 13417

*Capacitor Color Codes.*

RESTRICTED

ADDENDA

20 February 1945

TM-11-242

ADDENDA  
to  
TECHNICAL MANUAL  
RADIO SET SCR-300-A

The following information published on Order No. 29310-Phila-44-01, corrects TM-11-242, 15 June 1943 and February 1945.

Personnel using the equipment and having custody of this technical manual will attach this addenda securely inside the front cover of the TM, and will enter suitable notations beside each changed paragraph in the TM to indicate the presence of this information.

Beginning with Serial No. 7104 to 9471, inclusive, Capacitor C24, fixed, ceramic: 100 mmf  $\pm 5\%$ , 500 w-v d-c. Signal Corps Stock No. 3D9100-57 is replaced by Capacitor C100, fixed, ceramic: 10,000mmf  $+60\%$ - $20\%$ , 120 w-v d-c, Signal Corps Stock No. 3DA10-160.

NOTE: After Serial No. 9471, Signal Corps Stock No. 3D9100-57 is used.

Beginning with Serial No. 9646, Resistor R66, variable 0.5 megohm, Signal Corps Stock No. 2Z7272 is replaced by Resistor R79 1.0 megohm, Signal Corps Stock No. 3Z7499-1.16.

ST/MD/MB

RESTRICTED

RESTRICTED

Resistor R69, fixed: 68,000 ohms  $\pm 10\%$  1/3  
watt, Signal Corps Stock No. 3RCAE683K is replaced  
by Resistor R80, fixed: 39,000 ohms,  $\pm 20\%$ , 1/3  
watt, Signal Corps Stock No. 3Z6639-8.

Resistor R67, fixed: 0.22 megohm,  $\pm 10\%$ , 1/3  
watt, Signal Corps Stock No. 3RC10BE224K is omitted.

RESTRICTED

bjc/sk

54P54408 Issue B





WAR DEPARTMENT  
**UNSATISFACTORY EQUIPMENT REPORT**

(Technical service) <b>FOR</b> FROM (Organization)	DATE <b>MATERIEL</b> (Station)
TO (Next superior headquarters) (Station) (Technical service)	

**COMPLETE MAJOR ITEM**

NOMENCLATURE	TYPE
MODEL	MANUFACTURER
U. S. A. REG. NO.	SERIAL NO. DATE RECEIVED
EQUIPMENT WITH WHICH USED (IF APPLICABLE)	

**NOMENCLATURE OF DEFECTIVE COMPONENT**

PART NO.	TYPE
MANUFACTURER	DATE INSTALLED

**LENGTH OF SERVICE**

DATE OF INITIAL TROUBLE	TOTAL PERIOD OF OPERATION BEFORE FAILURE (FILL IN WHERE APPLICABLE)					
	YEARS	MONTHS	DAYS	HOURS	MILES	ROUNDS
TOTAL TIME INSTALLED						

**DESCRIPTION OF TROUBLE AND PROBABLE CAUSE**

GIVE TYPE OF FAILURE, MECHANICAL, ELECTRICAL, WORKMANSHIP, MATERIAL, DESIGN

**UNUSUAL SERVICE CONDITIONS**

GIVE BRIEF DESCRIPTION

TRAINING OR SKILL OF USING PERSONNEL (CHECK ONE)	POOR	FAIR	GOOD
DESCRIPTION OF ANY REMEDIAL ACTION TAKEN			

**RECOMMENDATIONS**

1ST IND. OFFICE STATION DATE (Technical service) <b>TO CHIEF</b> NAME STATION RANK	ORIGINATING OFFICER SIGNATURE NAME RANK AND TITLE ORGANIZATION
---	--

**INSTRUCTIONS**

1. It is imperative that the Chief of Technical Service concerned be advised at the earliest practical moment of any constructional, design, or operational defect in matériel. This form is designed to facilitate such reports and to provide a uniform method of submitting the required data.
2. This form will be used for reporting manufacturing, design or operational defects in matériel with a view to improving and correcting such defects, and for use in recommending modifications of matériel.
3. This form will not be used for reporting failures, isolated material defects or malfunctions of matériel resulting from fair-wear-and-tear or accidental damage nor for the replacement, repair, or the issue of parts and equipment. It does not replace currently authorized operational or performance records.
4. Reports of malfunctions and accidents involving ammunition will continue to be submitted as directed in the manner described in AR 750-10 (Change No. 3).
5. It will not be practicable or desirable in all cases to fill all blank spaces of the report. However, the report should be as complete as possible in order to expedite necessary corrective action. Additional pertinent information not provided for in the blank spaces should be submitted as inclosures to the form. Photographs, sketches or other illustrative material are highly desirable.
6. When cases arise where it is necessary to communicate with a chief of service in order to assure safety to personnel, more expeditious means of communication are authorized. This form should be used to confirm reports made by more expeditious means.
7. This form will be made out by using or service organizations and forwarded in duplicate through command channels to the chief of technical service. The office of the chief of technical service receiving the report will forward an information copy to the Commanding General, Army Ground Forces or Army Air Forces, whichever is applicable, and to the Commanding General, Army Service Forces.
8. Necessity for using this form will be determined by the using or service troops.